



## LOW NOISE, VERY LOW DRIFT, PRECISION VOLTAGE REFERENCE

Check for Samples: [REF5025-HT](#)

### FEATURES

- Low Temperature Drift: 20 ppm/°C
- Low Noise: 3  $\mu\text{V}_{\text{PP}}/\text{V}$
- High Output Current:  $\pm 7\text{ mA}$

### APPLICATIONS

- Down-Hole Drilling
- High Temperature Environments

### SUPPORTS EXTREME TEMPERATURE APPLICATIONS

- Controlled Baseline
- One Assembly/Test Site
- One Fabrication Site
- Available in Extreme ( $-55^{\circ}\text{C}/210^{\circ}\text{C}$ ) Temperature Range<sup>(1)</sup>
- Extended Product Life Cycle
- Extended Product-Change Notification
- Product Traceability
- Texas Instruments high temperature products utilize highly optimized silicon (die) solutions with design and process enhancements to maximize performance over extended temperatures.

(1) Custom temperature ranges available

### DESCRIPTION

The REF5025 is a low-noise, low-drift, very high precision voltage reference. This reference is capable of both sinking and sourcing, and is very robust with regard to line and load changes.

Temperature drift (20 ppm/°C) from  $-55^{\circ}\text{C}$  to  $210^{\circ}\text{C}$  is achieved using proprietary design techniques. These features combined with very low noise make the REF5025 ideal for use in down-hole drilling applications.

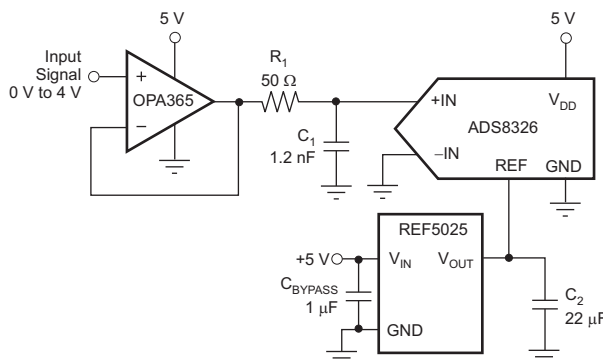

HKJ PACKAGE  
(TOP VIEW)

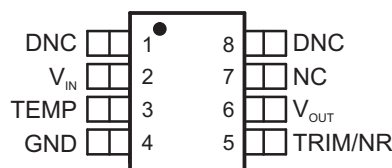

DNC = Do not connect  
NC = No internal connection



Please be aware that an important notice concerning availability, standard warranty, and use in critical applications of Texas Instruments semiconductor products and disclaimers thereto appears at the end of this data sheet.

All trademarks are the property of their respective owners.



This integrated circuit can be damaged by ESD. Texas Instruments recommends that all integrated circuits be handled with appropriate precautions. Failure to observe proper handling and installation procedures can cause damage.

ESD damage can range from subtle performance degradation to complete device failure. Precision integrated circuits may be more susceptible to damage because very small parametric changes could cause the device not to meet its published specifications.

### BARE DIE INFORMATION

DIE THICKNESS	BACKSIDE FINISH	BACKSIDE POTENTIAL	BOND PAD METALLIZATION COMPOSITION	BOND PAD THICKNESS
15 mils.	Silicon with backgrind	GND	Al-Cu (0.5%)	598 nm

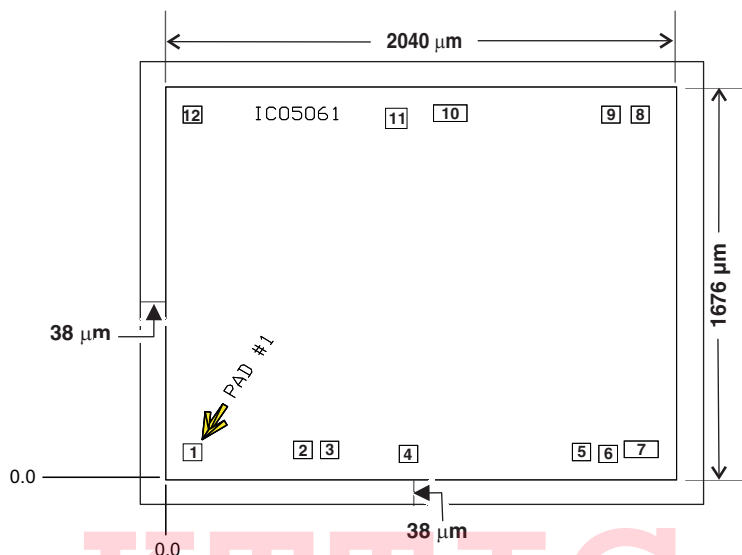

Table 1. Bond Pad Coordinates in Microns

DISCRIPTION	PAD NUMBER	X min	Y min	X max	Y max
NC	1	35.45	46.55	111.45	122.55
NC	2	496.75	56.55	572.75	132.55
VIN	3	607.45	56.55	683.45	132.55
NC	4	937.9	39.4	1013.9	115.4
TEMP	5	1660.1	47.2	1736.1	123.2
GND	6	1770.9	38.85	1847.05	115
GND	7	1877.1	59.6	2016.8	135.6
TRIM/NR	8	1904.65	1553.4	1980.65	1629.4
NC	9	1782.15	1553.4	1858.15	1629.4
VOUT	10	1080.2	1559.85	1219.9	1636
VOUT	11	880.25	1543.55	956.25	1619.55
NC	12	35.45	1553.45	111.45	1629.45

### ORDERING INFORMATION<sup>(1)</sup>

T <sub>A</sub>	PACKAGE <sup>(2)</sup>	ORDERABLE PART NUMBER	TOP-SIDE MARKING
-55°C to 210°C	KGD (bare die)	REF5025SKGD1	NA
	HKJ	REF5025SHKJ	REF5025SHKJ

(1) For the most current package and ordering information, see the Package Option Addendum at the end of this document, or see the TI web site at [www.ti.com](http://www.ti.com).

(2) Package drawings, thermal data, and symbolization are available at [www.ti.com/packaging](http://www.ti.com/packaging).

### ABSOLUTE MAXIMUM RATINGS<sup>(1)</sup>

		UNIT
Input Voltage		18 V
Output Short-Circuit		30 mA
Operating Temperature Range		–55 to 210 °C
Storage Temperature Range		–65 to 210 °C
Junction Temperature (T <sub>J</sub> max)		210 °C
ESD Rating	Human Body Model (HBM)	3000 V
	Charged Device Model (CDM)	1000 V

(1) Stresses above these ratings may cause permanent damage. Exposure to absolute maximum conditions for extended periods may degrade device reliability. These are stress ratings only, and functional operation of the device at these or any other conditions beyond those specified is not implied.

### THERMAL CHARACTERISTICS FOR HKJ PACKAGE

over operating free-air temperature range (unless otherwise noted)

PARAMETER		MIN	TYP	MAX	UNIT
θ <sub>JC</sub>	Junction-to-case thermal resistance			5.7	°C/W
				13.7	

### ELECTRICAL CHARACTERISTICS

T<sub>A</sub> = 25°C, I<sub>LOAD</sub> = 0, C<sub>L</sub> = 1 μF, V<sub>IN</sub> = 3.25 V to 18 V (unless otherwise noted).

PARAMETER	CONDITIONS	T <sub>A</sub> = –55 to 125°C			T <sub>A</sub> = 210°C			UNIT
		MIN	TYP	MAX	MIN	TYP	MAX	
<b>OUTPUT VOLTAGE (2.5 V)</b>								
Output voltage	V <sub>OUT</sub>		2.5		2.5			V
Initial accuracy <sup>(1)</sup>	V <sub>IN</sub> = 3.25 V	0		0.9	0.14			%
<b>NOISE</b>								
Output voltage noise	f = 0.1 Hz to 10 Hz		7.5					μV <sub>PP</sub>
<b>OUTPUT VOLTAGE TEMPERATURE DRIFT</b>								
Output voltage temperature drift <sup>(2)</sup>	dV <sub>OUT</sub> /dT	Calculated from –55°C to 210°C			20			ppm/°C
<b>LINE REGULATION</b>								
Line regulation	dV <sub>OUT</sub> /dV <sub>IN</sub>	From V <sub>IN</sub> = 3.25 V to V <sub>IN</sub> = 18 V			63	215		ppm/V
<b>LOAD REGULATION</b>								
Load regulation	dV <sub>OUT</sub> /dI <sub>LOAD</sub>	–7 mA < I <sub>LOAD</sub> < 10 mA, V <sub>IN</sub> = 3.25 V			20	75		ppm/mA
<b>SHORT-CIRCUIT CURRENT</b>								
Short-circuit current	I <sub>SC</sub>	V <sub>OUT</sub> = 0 V			11			mA
<b>TEMP PIN</b>								
Voltage output		At T <sub>A</sub> = 25°C						mV
Temperature sensitivity <sup>(3)</sup>			2.64					mV/°C
<b>TURN-ON SETTLING TIME</b>								
Turn-on settling time		To 0.1% with C <sub>L</sub> = 1 μF			200			μs
<b>POWER SUPPLY</b>								
Supply voltage	V <sub>S</sub>	3.25		18	3.25		18	V
Quiescent current			0.8	1.2			1.5	mA
<b>TEMPERATURE RANGE</b>								
Specified range		–55°C to 210°C						

(1) Refer to Figure 5 of the TYPICAL CHARACTERISTICS.

(2) Refer to Figure 4 of the TYPICAL CHARACTERISTICS.

(3) Refer to Figure 10 of the TYPICAL CHARACTERISTICS.

**ELECTRICAL CHARACTERISTICS (continued)**

$T_A = 25^\circ\text{C}$ ,  $I_{\text{LOAD}} = 0$ ,  $C_L = 1 \mu\text{F}$ ,  $V_{\text{IN}} = 3.25 \text{ V to } 18 \text{ V}$  (unless otherwise noted).

PARAMETER	CONDITIONS	$T_A = -55 \text{ to } 125^\circ\text{C}$			$T_A = 210^\circ\text{C}$			UNIT
		MIN	TYP	MAX	MIN	TYP	MAX	
Operating range	$-55^\circ\text{C to } 210^\circ\text{C}$							

KTTIC

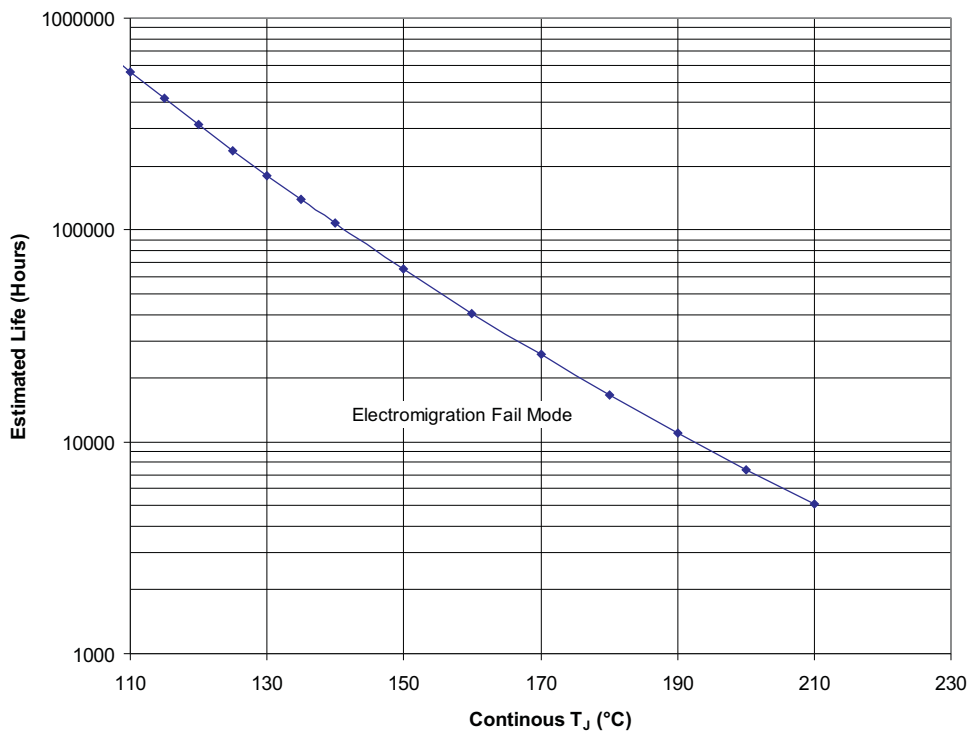

Figure 1. REF5025SKGD1 Operating Life Derating Chart

Notes:

1. See datasheet for Absolute Maximum and minimum Recommended Operating Conditions.
2. Silicon operating life design goal is 10 years at 105°C junction temperature ( does not include package interconnect life).

TYPICAL CHARACTERISTICS

$T_A = 25^\circ\text{C}$ ,  $I_{LOAD} = 0$ ,  $V_S = 3.25\text{ V}$  (unless otherwise noted).

TEMPERATURE DRIFT  
(0°C to 85°C)

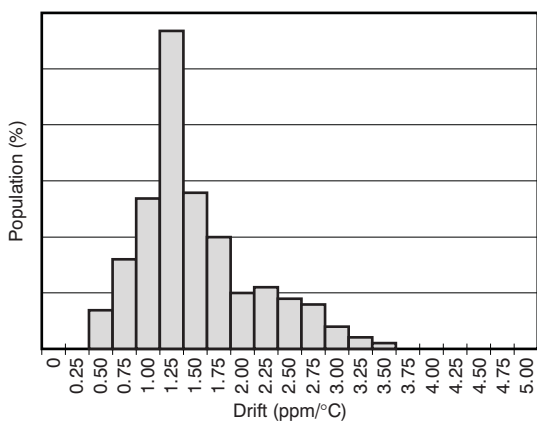

Figure 2.

TEMPERATURE DRIFT  
(-40°C to 125°C)

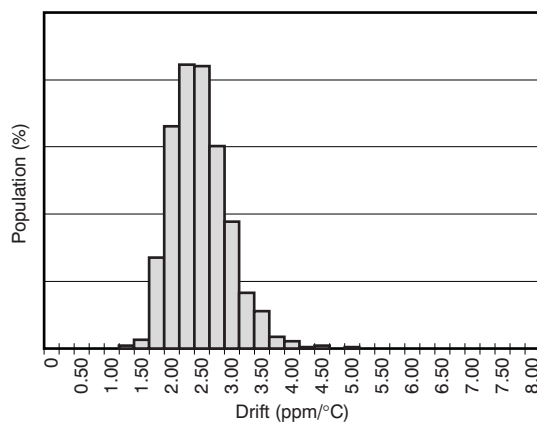
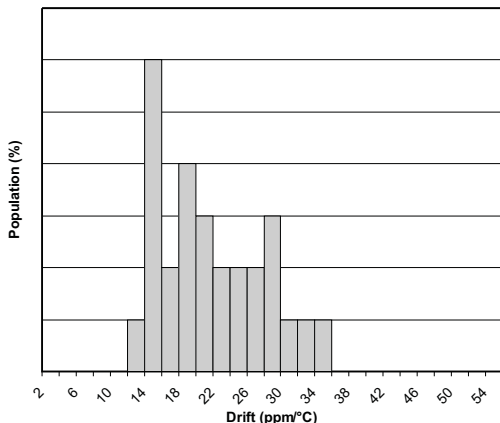

Figure 3.

**TYPICAL CHARACTERISTICS (continued)**

$T_A = 25^\circ\text{C}$ ,  $I_{\text{LOAD}} = 0$ ,  $V_S = 3.25\text{ V}$  (unless otherwise noted).

**TEMPERATURE DRIFT  
( $-55^\circ\text{C}$  to  $210^\circ\text{C}$ )**



**Figure 4.**

**OUTPUT VOLTAGE  
INITIAL ACCURACY  
(AT  $210^\circ\text{C}$ )**

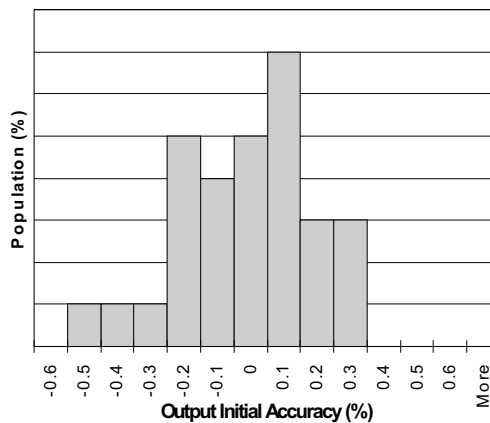

**Figure 5.**

**OUTPUT VOLTAGE ACCURACY  
VS  
TEMPERATURE**

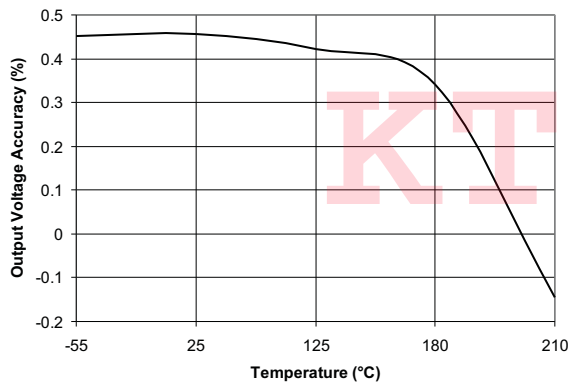

**Figure 6.**

**POWER-SUPPLY REJECTION RATIO  
VS  
FREQUENCY**

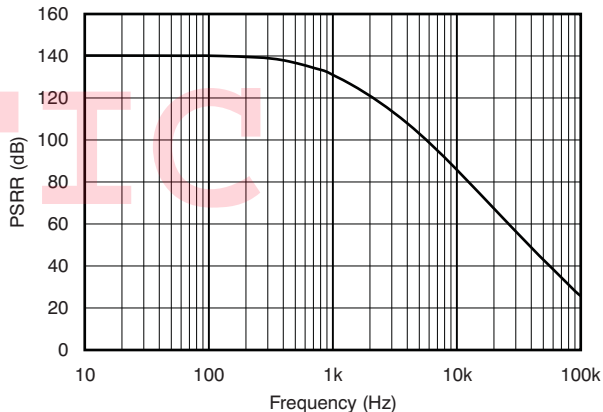

**Figure 7.**

**TYPICAL CHARACTERISTICS (continued)**

$T_A = 25^\circ\text{C}$ ,  $I_{\text{LOAD}} = 0$ ,  $V_S = 3.25\text{ V}$  (unless otherwise noted).

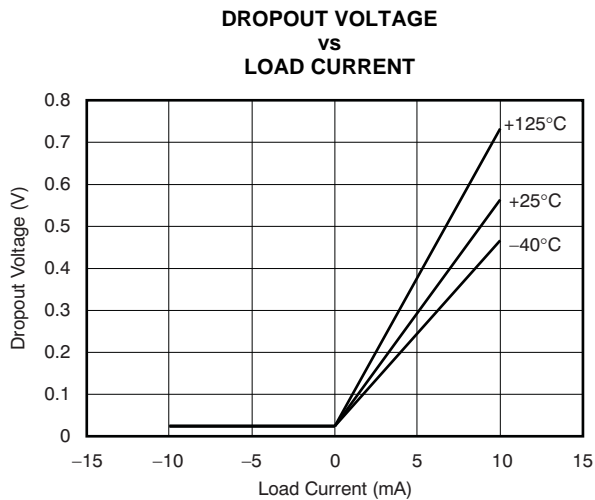

Figure 8.

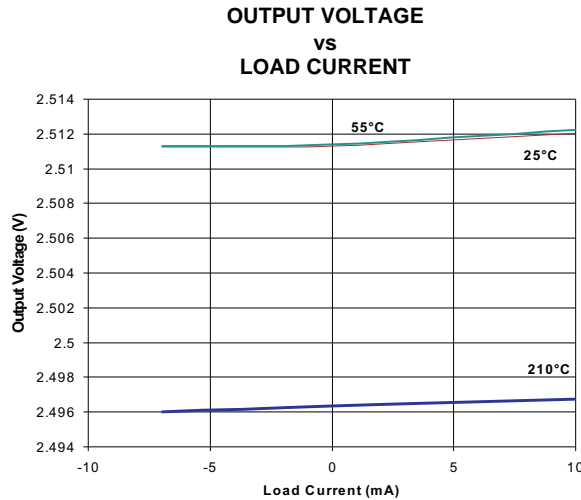

Figure 9.

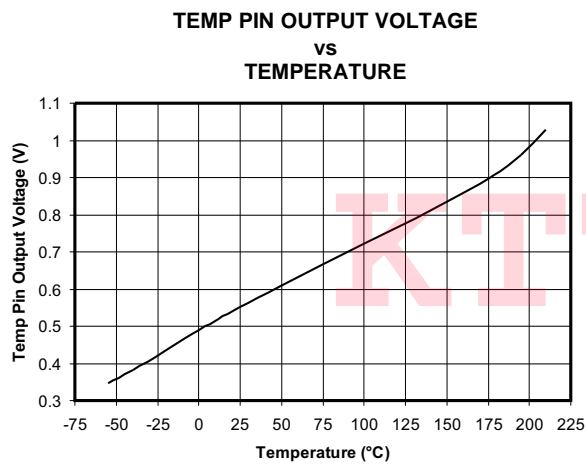

Figure 10.

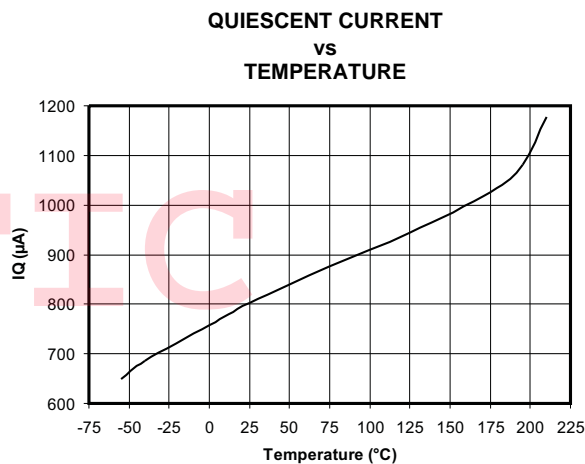

Figure 11.

**TYPICAL CHARACTERISTICS (continued)**

$T_A = 25^\circ\text{C}$ ,  $I_{\text{LOAD}} = 0$ ,  $V_S = 3.25\text{ V}$  (unless otherwise noted).

**QUIESCENT CURRENT  
vs  
INPUT VOLTAGE**

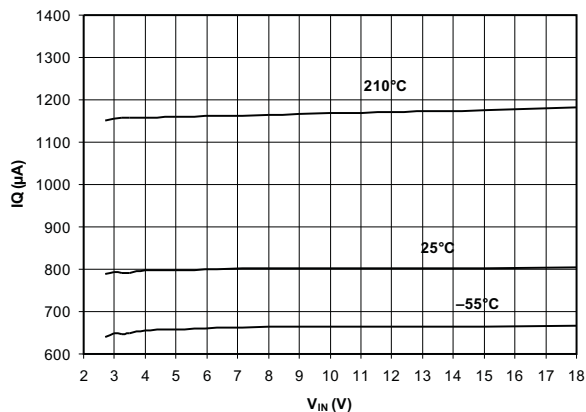

Figure 12.

**LINE REGULATION  
vs  
TEMPERATURE**

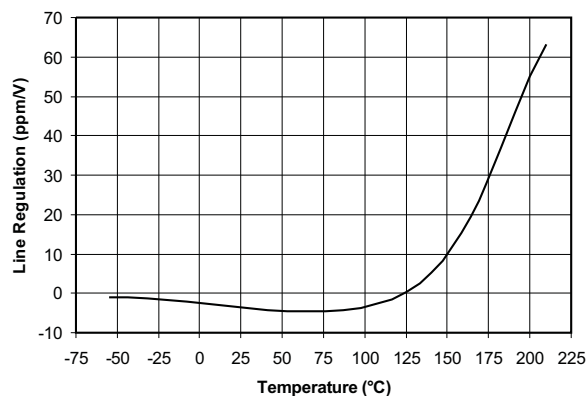

Figure 13.

**SHORT-CIRCUIT CURRENT  
vs  
TEMPERATURE**

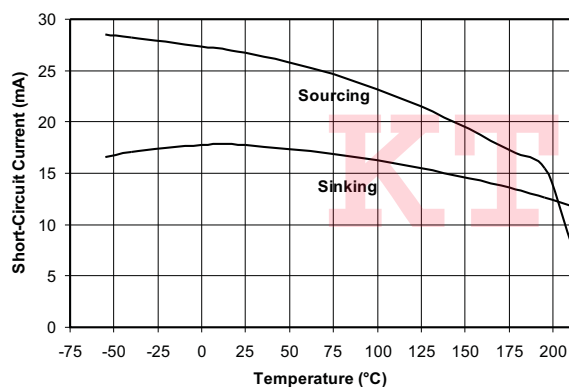

Figure 14.

**NOISE**

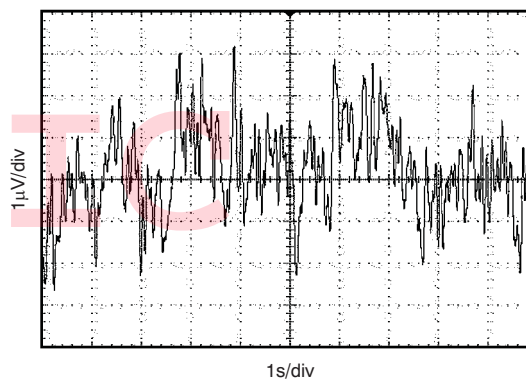

Figure 15.

**STARTUP  
(REF5025,  $C_L = 1\ \mu\text{F}$ )**

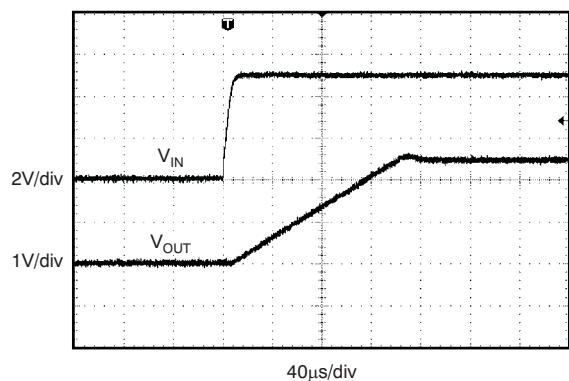

Figure 16.

**STARTUP  
(REF5025,  $C_L = 10\ \mu\text{F}$ )**

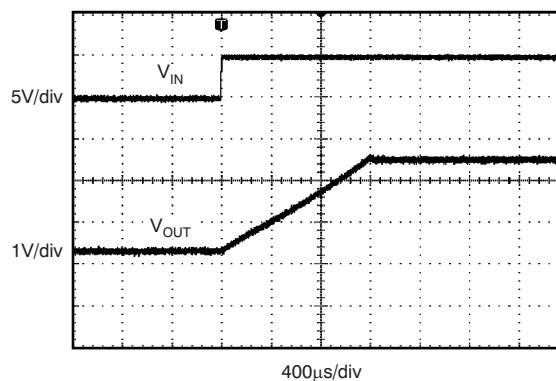

Figure 17.



**TYPICAL CHARACTERISTICS (continued)**

$T_A = 25^\circ\text{C}$ ,  $I_{\text{LOAD}} = 0$ ,  $V_S = 3.25\text{ V}$  (unless otherwise noted).

**LOAD TRANSIENT**  
 $(C_L = 1\ \mu\text{F}, I_{\text{OUT}} = 1\ \text{mA})$

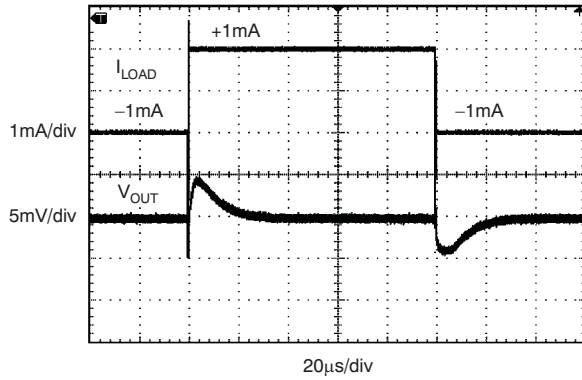

Figure 18.

**LOAD TRANSIENT**  
 $(C_L = 1\ \mu\text{F}, I_{\text{OUT}} = 10\ \text{mA})$

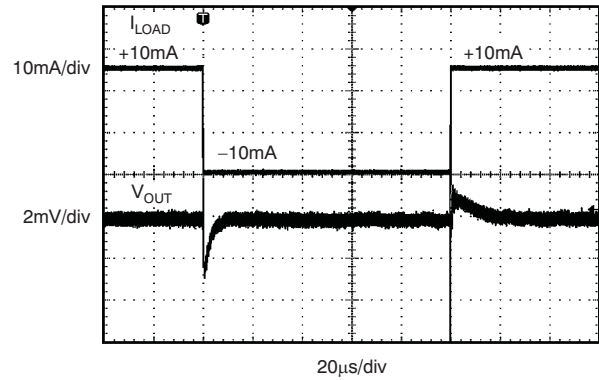

Figure 19.

**LOAD TRANSIENT**  
 $(C_L = 10\ \mu\text{F}, I_{\text{OUT}} = 1\ \text{mA})$

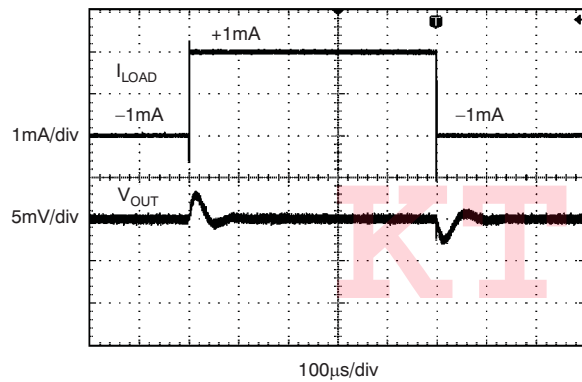

Figure 20.

**LOAD TRANSIENT**  
 $(C_L = 10\ \mu\text{F}, I_{\text{OUT}} = 10\ \text{mA})$

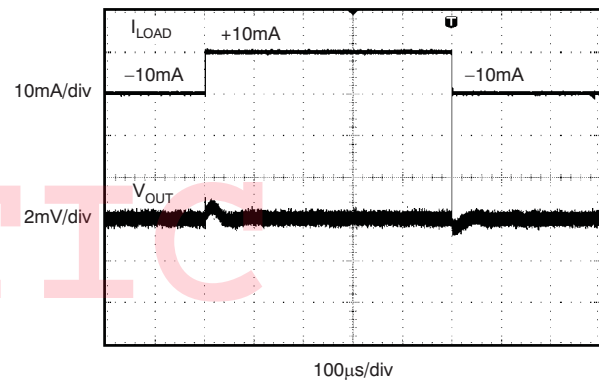

Figure 21.

**LINE TRANSIENT**  
 $(C_L = 1\ \mu\text{F})$

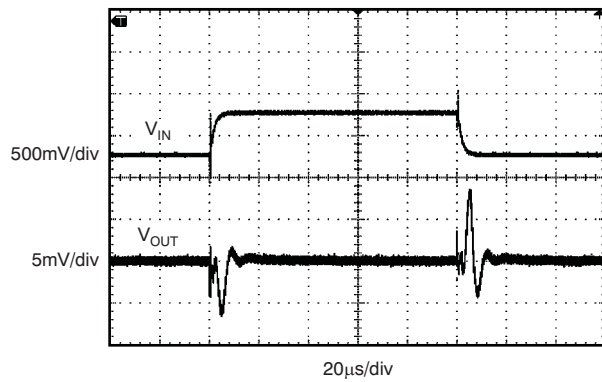

Figure 22.

**LINE TRANSIENT**  
 $(C_L = 10\ \mu\text{F})$

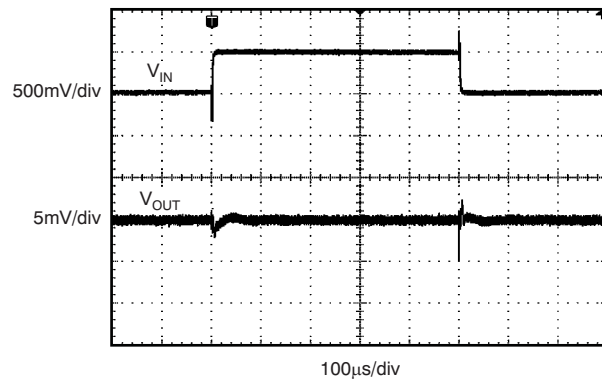

Figure 23.

### APPLICATION INFORMATION

The REF5025 is a low-noise, precision bandgap voltage reference that is specifically designed for excellent initial voltage accuracy and drift. Figure 24 shows a simplified block diagram of the REF5025.

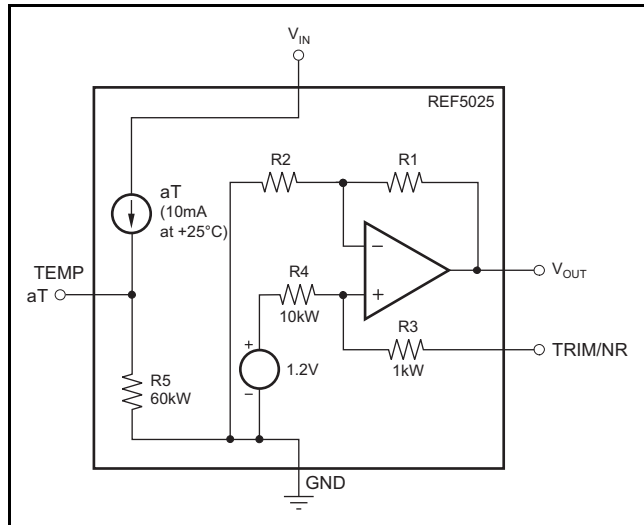

Figure 24. REF5025 Simplified Block Diagram

### BASIC CONNECTIONS

Figure 25 shows the typical connections for the REF5025. A supply bypass capacitor ranging between 1  $\mu$ F to 10  $\mu$ F is recommended. A 1- $\mu$ F to 50- $\mu$ F, low-ESR output capacitor ( $C_L$ ) must be connected from  $V_{OUT}$  to GND. The ESR value should be less than or equal to 1.5  $\Omega$ . The ESR minimizes gain peaking of the internal 1.2-V reference and thus reduces noise at the  $V_{OUT}$  pin.

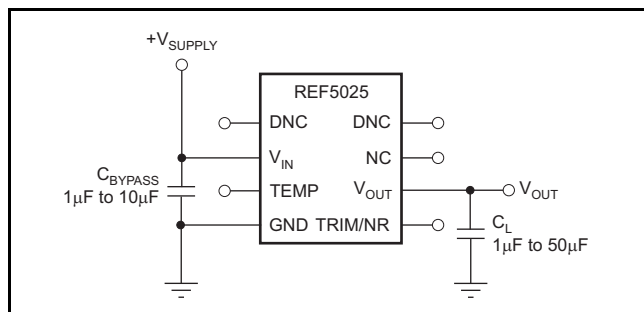

Figure 25. Basic Connections

### SUPPLY VOLTAGE

The REF5025 features extremely low dropout voltage. For loaded conditions, a typical dropout voltage versus load plot is shown in Figure 8 of Typical Characteristics.

### USING THE TRIM/NR PIN

The REF5025 provides a very accurate voltage output. However,  $V_{OUT}$  can be adjusted to reduce noise and shift the output voltage from the nominal value by configuring the trim and noise reduction pin (TRIM/NR, pin 5). The TRIM/NR pin provides a  $\pm 15$ -mV adjustment of the device bandgap, which produces a  $\pm 15$ -mV change on the  $V_{OUT}$  pin. Figure 26 shows a typical circuit using the TRIM/NR pin to adjust  $V_{OUT}$ . When using this technique, the temperature coefficients of the resistors can degrade the temperature drift at the output.

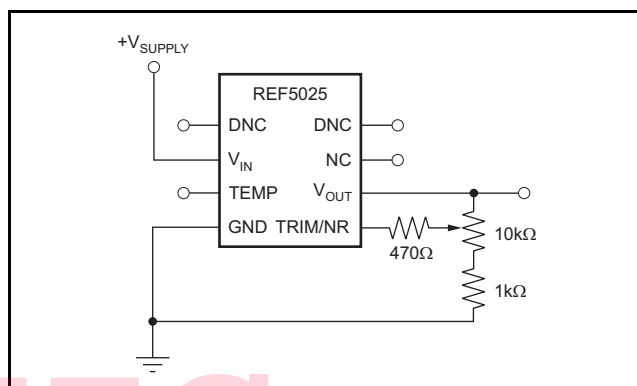

Figure 26.  $V_{OUT}$  Adjustment Using TRIM/NR Pin

The REF5025 allows access to the bandgap through the TRIM/NR pin. Placing a capacitor from the TRIM/NR pin to GND (as Figure 27 illustrates) in combination with the internal 1-k $\Omega$  resistor creates a low-pass filter that lowers the overall noise measured on the  $V_{OUT}$  pin. A capacitance of 1  $\mu$ F is suggested for a low-pass filter with a corner frequency of 14.5 Hz. Higher capacitance results in a lower cutoff frequency.

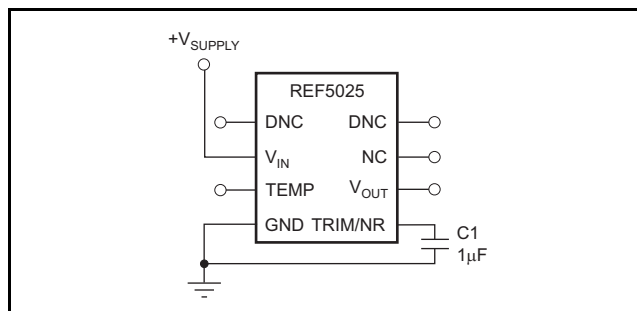

Figure 27. Noise Reduction Using TRIM/NR Pin

## TEMPERATURE DRIFT

The REF5025 is designed for minimal drift error, which is defined as the change in output voltage over temperature. The drift is calculated using the box method, as described by the following equation:

$$\text{Drift} = \left( \frac{V_{\text{OUTMAX}} - V_{\text{OUTMIN}}}{V_{\text{OUT}} \times \text{Temp Range}} \right) \times 10^6 (\text{ppm}) \quad (1)$$

## TEMPERATURE MONITORING

The temperature output terminal (TEMP, pin 3) provides a temperature-dependent voltage output with approximately 60-kΩ source impedance. As seen in [Figure 10](#), the output voltage follows the nominal relationship:

$$V_{\text{TEMP PIN}} = 509 \text{ mV} + 2.64 \times T(^{\circ}\text{C}) \quad (2) \quad (2)$$

(For  $-55^{\circ}\text{C}$  to  $125^{\circ}\text{C}$  only. Refer to [Figure 10](#) of the TYPICAL CHARACTERISTICS for  $125^{\circ}\text{C}$  to  $210^{\circ}\text{C}$ .)

This pin indicates general chip temperature, accurate to approximately  $\pm 15^{\circ}\text{C}$ . Although it is not generally suitable for accurate temperature measurements, it can be used to indicate temperature changes or for temperature compensation of analog circuitry. A temperature change of  $30^{\circ}\text{C}$  corresponds to an approximate 79-mV change in voltage at the TEMP pin.

The TEMP pin has high output impedance (see [Figure 24](#)). Loading this pin with a low-impedance circuit induces a measurement error; however, it does not have any effect on  $V_{\text{OUT}}$  accuracy. To avoid errors caused by low-impedance loading, buffer the TEMP pin output with a suitable low-temperature drift op amp, such as the [OPA333](#), [OPA335](#), or [OPA376](#), as shown in [Figure 28](#).

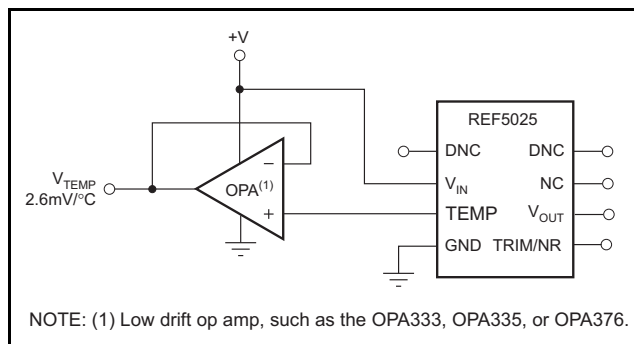

Figure 28. Buffering the TEMP Pin Output

## POWER DISSIPATION

The REF5025 is specified to deliver current loads of  $\pm 10 \text{ mA}$  over the specified input voltage range. The temperature of the device increases according to the equation:

$$T_J = T_A + P_D \times \theta_{JA} \quad (3) \quad (3)$$

Where:

$T_J$  = Junction temperature ( $^{\circ}\text{C}$ )

$T_A$  = Ambient temperature ( $^{\circ}\text{C}$ )

$P_D$  = Power dissipated (W)

$\theta_{JA}$  = Junction-to-ambient thermal resistance ( $^{\circ}\text{C}/\text{W}$ )

The REF5025 junction temperature must not exceed the absolute maximum rating of  $210^{\circ}\text{C}$ .

## NOISE PERFORMANCE

Typical 0.1-Hz to 10-Hz voltage noise for each member of the REF5025 is specified in the Electrical Characteristics table. The noise voltage increases with output voltage and operating temperature. Additional filtering can be used to improve output noise levels, although care should be taken to ensure the output impedance does not degrade performance.

### APPLICATION CIRCUITS

#### NEGATIVE REFERENCE VOLTAGE

For applications requiring a negative and positive reference voltage, the REF5025 and OPA735 can be used to provide a dual-supply reference from a 5-V supply. Figure 29 shows the REF5025 used to provide a 2.5-V supply reference voltage. The low drift performance of the REF5025 complements the low offset voltage and zero drift of the OPA735 to provide an accurate solution for split-supply applications. Care must be taken to match the temperature coefficients of  $R_1$  and  $R_2$ .

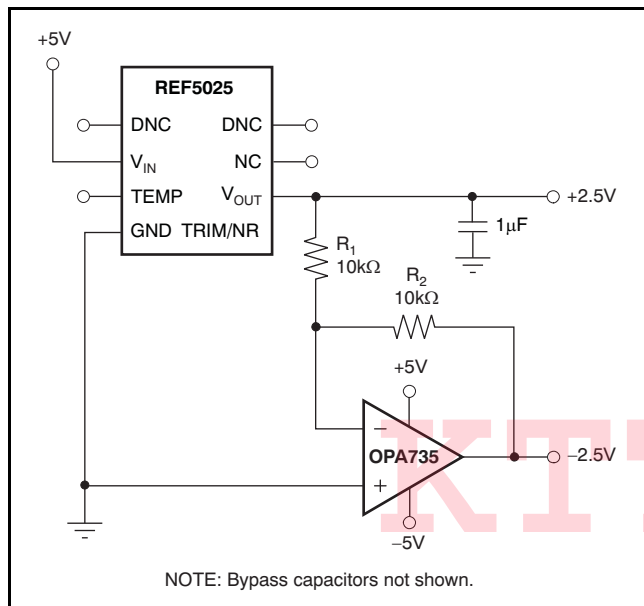

Figure 29. The REF5025 and OPA735 Create Positive and Negative Reference Voltages

#### DATA ACQUISITION

Data acquisition systems often require stable voltage references to maintain accuracy. The REF5025 features low noise, very low drift, and high initial accuracy for high-performance data converters. Figure 30 shows the REF5025 in a basic data acquisition system.

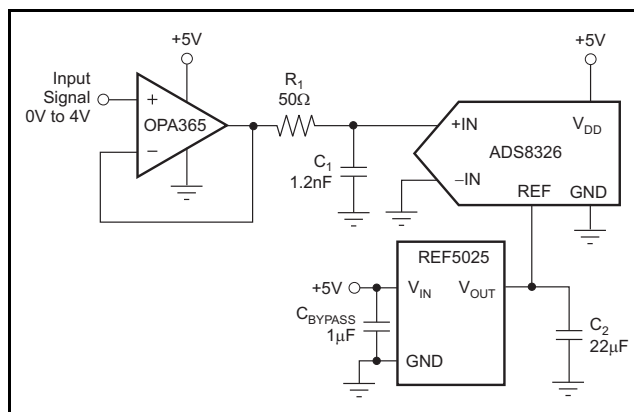

Figure 30. Basic Data Acquisition System

**PACKAGING INFORMATION**

Orderable Device	Status <sup>(1)</sup>	Package Type	Package Drawing	Pins	Package Qty	Eco Plan <sup>(2)</sup>	Lead/Ball Finish	MSL Peak Temp <sup>(3)</sup>
REF5025SHKJ	ACTIVE	CFP	HKJ	8	1	TBD	Call TI	N / A for Pkg Type
REF5025SKGD1	ACTIVE	XCEPT	KGD	0	195	TBD	Call TI	N / A for Pkg Type

<sup>(1)</sup> The marketing status values are defined as follows:

**ACTIVE:** Product device recommended for new designs.

**LIFEBUY:** TI has announced that the device will be discontinued, and a lifetime-buy period is in effect.

**NRND:** Not recommended for new designs. Device is in production to support existing customers, but TI does not recommend using this part in a new design.

**PREVIEW:** Device has been announced but is not in production. Samples may or may not be available.

**OBsolete:** TI has discontinued the production of the device.

<sup>(2)</sup> Eco Plan - The planned eco-friendly classification: Pb-Free (RoHS), Pb-Free (RoHS Exempt), or Green (RoHS & no Sb/Br) - please check <http://www.ti.com/productcontent> for the latest availability information and additional product content details.

**TBD:** The Pb-Free/Green conversion plan has not been defined.

**Pb-Free (RoHS):** TI's terms "Lead-Free" or "Pb-Free" mean semiconductor products that are compatible with the current RoHS requirements for all 6 substances, including the requirement that lead not exceed 0.1% by weight in homogeneous materials. Where designed to be soldered at high temperatures, TI Pb-Free products are suitable for use in specified lead-free processes.

**Pb-Free (RoHS Exempt):** This component has a RoHS exemption for either 1) lead-based flip-chip solder bumps used between the die and package, or 2) lead-based die adhesive used between the die and leadframe. The component is otherwise considered Pb-Free (RoHS compatible) as defined above.

**Green (RoHS & no Sb/Br):** TI defines "Green" to mean Pb-Free (RoHS compatible), and free of Bromine (Br) and Antimony (Sb) based flame retardants (Br or Sb do not exceed 0.1% by weight in homogeneous material)

<sup>(3)</sup> MSL, Peak Temp. -- The Moisture Sensitivity Level rating according to the JEDEC industry standard classifications, and peak solder temperature.

**Important Information and Disclaimer:** The information provided on this page represents TI's knowledge and belief as of the date that it is provided. TI bases its knowledge and belief on information provided by third parties, and makes no representation or warranty as to the accuracy of such information. Efforts are underway to better integrate information from third parties. TI has taken and continues to take reasonable steps to provide representative and accurate information but may not have conducted destructive testing or chemical analysis on incoming materials and chemicals. TI and TI suppliers consider certain information to be proprietary, and thus CAS numbers and other limited information may not be available for release.

In no event shall TI's liability arising out of such information exceed the total purchase price of the TI part(s) at issue in this document sold by TI to Customer on an annual basis.

HKJ (R-CDFP-F8)

CERAMIC DUAL FLATPACK

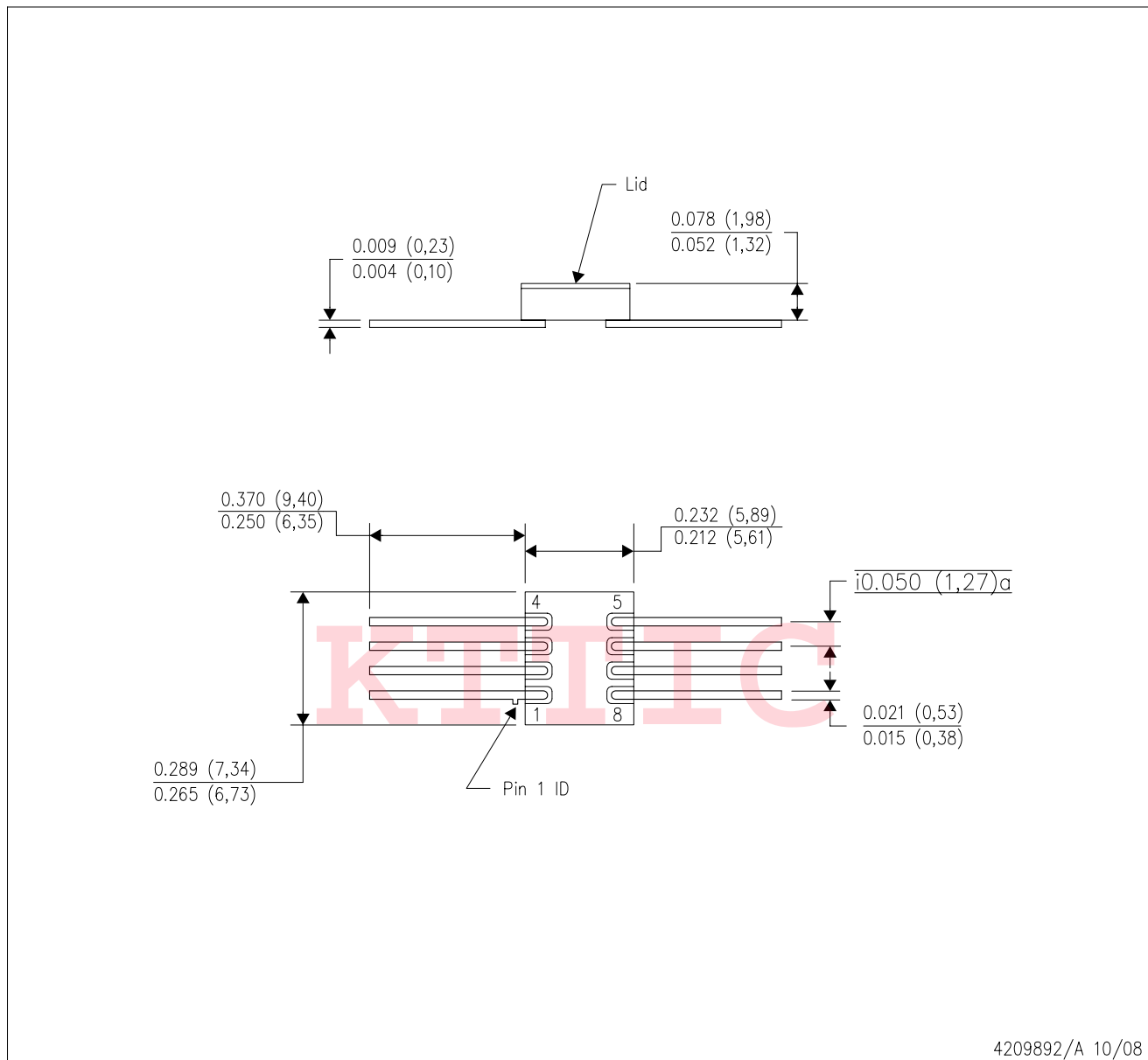

- NOTES:
- A. All linear dimensions are in inches (millimeters).
  - B. This drawing is subject to change without notice.
  - C. This package can be hermetically sealed with a metal lid.
  - D. The terminals will be gold plated.

**IMPORTANT NOTICE**

Texas Instruments Incorporated and its subsidiaries (TI) reserve the right to make corrections, modifications, enhancements, improvements, and other changes to its products and services at any time and to discontinue any product or service without notice. Customers should obtain the latest relevant information before placing orders and should verify that such information is current and complete. All products are sold subject to TI's terms and conditions of sale supplied at the time of order acknowledgment.

TI warrants performance of its hardware products to the specifications applicable at the time of sale in accordance with TI's standard warranty. Testing and other quality control techniques are used to the extent TI deems necessary to support this warranty. Except where mandated by government requirements, testing of all parameters of each product is not necessarily performed.

TI assumes no liability for applications assistance or customer product design. Customers are responsible for their products and applications using TI components. To minimize the risks associated with customer products and applications, customers should provide adequate design and operating safeguards.

TI does not warrant or represent that any license, either express or implied, is granted under any TI patent right, copyright, mask work right, or other TI intellectual property right relating to any combination, machine, or process in which TI products or services are used. Information published by TI regarding third-party products or services does not constitute a license from TI to use such products or services or a warranty or endorsement thereof. Use of such information may require a license from a third party under the patents or other intellectual property of the third party, or a license from TI under the patents or other intellectual property of TI.

Reproduction of TI information in TI data books or data sheets is permissible only if reproduction is without alteration and is accompanied by all associated warranties, conditions, limitations, and notices. Reproduction of this information with alteration is an unfair and deceptive business practice. TI is not responsible or liable for such altered documentation. Information of third parties may be subject to additional restrictions.

Resale of TI products or services with statements different from or beyond the parameters stated by TI for that product or service voids all express and any implied warranties for the associated TI product or service and is an unfair and deceptive business practice. TI is not responsible or liable for any such statements.

TI products are not authorized for use in safety-critical applications (such as life support) where a failure of the TI product would reasonably be expected to cause severe personal injury or death, unless officers of the parties have executed an agreement specifically governing such use. Buyers represent that they have all necessary expertise in the safety and regulatory ramifications of their applications, and acknowledge and agree that they are solely responsible for all legal, regulatory and safety-related requirements concerning their products and any use of TI products in such safety-critical applications, notwithstanding any applications-related information or support that may be provided by TI. Further, Buyers must fully indemnify TI and its representatives against any damages arising out of the use of TI products in such safety-critical applications.

TI products are neither designed nor intended for use in military/aerospace applications or environments unless the TI products are specifically designated by TI as military-grade or "enhanced plastic." Only products designated by TI as military-grade meet military specifications. Buyers acknowledge and agree that any such use of TI products which TI has not designated as military-grade is solely at the Buyer's risk, and that they are solely responsible for compliance with all legal and regulatory requirements in connection with such use.

TI products are neither designed nor intended for use in automotive applications or environments unless the specific TI products are designated by TI as compliant with ISO/TS 16949 requirements. Buyers acknowledge and agree that, if they use any non-designated products in automotive applications, TI will not be responsible for any failure to meet such requirements.

Following are URLs where you can obtain information on other Texas Instruments products and application solutions:

<b>Products</b>		<b>Applications</b>	
Amplifiers	<a href="http://amplifier.ti.com">amplifier.ti.com</a>	Audio	<a href="http://www.ti.com/audio">www.ti.com/audio</a>
Data Converters	<a href="http://dataconverter.ti.com">dataconverter.ti.com</a>	Automotive	<a href="http://www.ti.com/automotive">www.ti.com/automotive</a>
DLP® Products	<a href="http://www.dlp.com">www.dlp.com</a>	Communications and Telecom	<a href="http://www.ti.com/communications">www.ti.com/communications</a>
DSP	<a href="http://dsp.ti.com">dsp.ti.com</a>	Computers and Peripherals	<a href="http://www.ti.com/computers">www.ti.com/computers</a>
Clocks and Timers	<a href="http://www.ti.com/clocks">www.ti.com/clocks</a>	Consumer Electronics	<a href="http://www.ti.com/consumer-apps">www.ti.com/consumer-apps</a>
Interface	<a href="http://interface.ti.com">interface.ti.com</a>	Energy	<a href="http://www.ti.com/energy">www.ti.com/energy</a>
Logic	<a href="http://logic.ti.com">logic.ti.com</a>	Industrial	<a href="http://www.ti.com/industrial">www.ti.com/industrial</a>
Power Mgmt	<a href="http://power.ti.com">power.ti.com</a>	Medical	<a href="http://www.ti.com/medical">www.ti.com/medical</a>
Microcontrollers	<a href="http://microcontroller.ti.com">microcontroller.ti.com</a>	Security	<a href="http://www.ti.com/security">www.ti.com/security</a>
RFID	<a href="http://www.ti-rfid.com">www.ti-rfid.com</a>	Space, Avionics & Defense	<a href="http://www.ti.com/space-avionics-defense">www.ti.com/space-avionics-defense</a>
RF/IF and ZigBee® Solutions	<a href="http://www.ti.com/lprf">www.ti.com/lprf</a>	Video and Imaging	<a href="http://www.ti.com/video">www.ti.com/video</a>
		Wireless	<a href="http://www.ti.com/wireless-apps">www.ti.com/wireless-apps</a>

Mailing Address: Texas Instruments, Post Office Box 655303, Dallas, Texas 75265  
Copyright © 2010, Texas Instruments Incorporated