



SPC560S50x, SPC560S60x

32-bit MCU for cluster applications with stepper motor, TFT graphic controller and LCD driver

Data Brief

Features

- High performance 64 MHz e200z0h CPU
 - 32-bit Power Architecture™ book E CPU
 - Up to 60 MIPs operation
 - Variable length encoding (VLE)
- Memory available
 - Up to 1 Mbyte on-chip Flash, with ECC
 - Up to 48 Kbytes on-chip RAM with ECC
 - 160 Kbytes on-chip graphic RAM
 - External flash extension via Quad-SPI
 - 12-entry memory protection unit
- Dashboard peripheral set
 - 6 stepper motor drivers with stall detection and zero positioning
 - 4 x 40 or 6 x 38 LCD display driver
 - Sound control
 - Real-time clock
- TFT display control unit
 - 4 x plane and cursor graphic controller
 - Display capable of driving up to WVGA
 - 24-bit RGB
 - Proprietary display input
- Interrupts and DMA
 - Up to 128 selectable interrupts
 - 16 priority levels
 - Nonmaskable interrupt (NMI)
 - Up to 32 external interrupts with 18 wakeup lines
 - 16-channel eDMA controller
- Up to 136 GPIOs in LQFP176
- Timer units
 - 4-channel 32-bit periodic interrupt timers
 - 4-channel 32-bit system timer module
 - Software watchdog timer
- Timed I/O
 - 8-channel 16-bit counter IC/OC
 - 16-channel 16-bit counter IC/OC/PWM

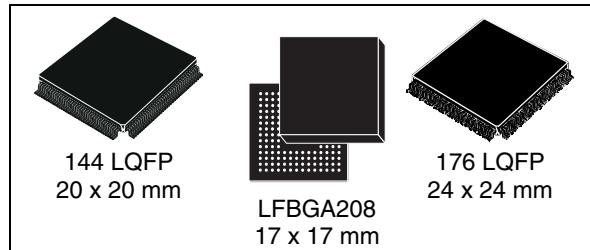

- Communications interface
 - 2 FlexCAN interfaces (2.0B active)
 - Up to 3 LINFlex/UART channels
 - Up to 3 DSPI channels, with one Quad-SPI
 - Up to 4 I²C interfaces
- 16/23-channel, 10-bit ADC converter
- On-chip CAN/UART bootstrap loader
- Clock generation
 - 4 to 16 MHz main oscillator
 - 32 kHz auxiliary oscillator
 - 16 MHz internal RC oscillator
 - 128 kHz internal RC oscillator for low power modes
 - Up to 2 software-controlled internal FMPLL modulated or not
- Exhaustive debugging capability
 - Nexus L1 on all devices
 - Nexus L2+ on LFBGA208 package
- Voltage supply
 - Single 5 V or 3.3 V supply for I/Os and ADC
 - On-chip voltage regulator with external ballast transistor
- 144 LQFP, 176 LQFP packages
- Operating temperature range -40 to 105 °C

Table 1. Device summary

Package	Part number	
	512 Kbyte Flash	1 Mbyte Flash
LQFP144	SPC560S50L5	SPC560S60L5
LQFP176		SPC560S60L7
LFBGA208*		SPC560S60L7

Contents

1	Introduction	4
2	Block diagram	5
3	Overview of the SPC560Sx Microcontroller	6
3.1	Device Comparison	6
3.2	Feature List	7
3.3	Feature Details	10
3.3.1	Low Power Operation	10
3.3.2	e200z0h Core Processor	12
3.3.3	Crossbar	13
3.3.4	eDMA	14
3.3.5	Inter IC Communications Module (I2C)	15
3.3.6	Interrupt Controller	15
3.3.7	QuadSPI Serial Flash Controller	16
3.3.8	System Integration Unit (SIU)	16
3.3.9	Flash	16
3.3.10	SRAM	17
3.3.11	On-chip Graphics SRAM	17
3.3.12	Memory Protection Unit (MPU)	18
3.3.13	Boot Assist Module (BAM)	18
3.3.14	eMIOS	18
3.3.15	Analog to Digital Converter Module (ADC)	20
3.3.16	Deserial Serial Peripheral Interface (DSPI)	21
3.3.17	FlexCAN	22
3.3.18	Serial Communication Interface Module (LINFlex)	23
3.3.19	System Clocks and Clock Generation Modules	24
3.3.20	Periodic Interrupt Timer Module (PIT)	25
3.3.21	Real Time Counter (RTC)	25
3.3.22	Software Timer Module (STM)	26
3.3.23	Software Watchdog Timer (SWT)	26
3.3.24	Display Control Unit (DCU)	26
3.3.25	Parallel Data Interface (PDI)	27
3.3.26	Liquid Crystal Display (LCD) Driver	28

3.3.27	Motor Control (MC)	28
3.3.28	Stepper Motor Stall Detect (SSD)	29
3.3.29	Sound Generation	29
3.3.30	IEEE 1149.1 JTAG Controller (JTAGC)	29
3.3.31	Nexus Development Interface (NDI)	30
4	Application Examples	31
4.1	Instrument Cluster with TFT Display	31
4.2	Instrument Cluster with LCD Segment Display	31
5	Developer Support	33
6	Orderable Parts	34
7	Document revision history	35



1 Introduction

The SPC560Sx family represents a new generation of 32-bit microcontrollers based on the Power Architecture™. These devices are targeted to address the next wave of automotive instrument cluster applications driven by significant growth in demand for color Thin Film Transistor (TFT) displays within the vehicle. The advanced and cost-efficient processor core of the family complies with the Power Architecture™ embedded category, which is 100% user-mode compatible with the original PowerPC user instruction set architecture (UISA). It offers high performance processing optimized for low power consumption, operating at speeds up to 64 MHz. The family itself is fully scalable from 256 KB up to 1 MB internal flash memory. The memory capacity can be further expanded via the on-chip QuadSPI serial flash controller module. Larger memory versions with greater graphics functionality are planned for the future.

The SPC560Sx family benefits from the extensive development infrastructure for Power Architecture devices which is already well established. This includes full support from available software drivers, operating systems and configuration code to assist with users' implementations. Refer to [Section 5: Developer Support](#) for more information.

The SPC560Sx family platform has a single level of memory hierarchy supporting on-chip SRAM and flash memories. The 1 MB flash version (SPC560S60) features 160 KB of on-chip graphics SRAM to buffer cost effective color TFT displays driven via the on-chip Display Control Unit (DCU). Refer to [Table 2](#) for specific memory and feature sets of the product family members.

The SPC560Sx family of microcontrollers are designed to reduce development and production costs of TFT-based instrument cluster displays by providing a single-chip solution with the processing and storage capacity to host and execute real-time application software and drive the TFT display directly. Operating at speeds of up to 64 MHz, these devices offer high performance processing with low power consumption. Memory and storage capacity can be further expanded via the on-chip Serial Peripheral Interface (SPI) and QuadSPI peripheral modules.

The SPC560Sx platform features up to 1 MB of on-chip flash memory, up to 160 KB of on-chip graphics SRAM and an on-chip Display Control Unit (DCU) designed to drive color TFT displays.

SPC560Sx devices are compatible with the existing development infrastructure of current Power Architecture™ devices and are supported with software drivers, operating systems and configuration code to assist with application development. Refer to [Section 5: Developer Support](#) for more information.

2 Block diagram

Figure 1 shows a top-level block diagram of the SPC560Sx microcontroller.

Figure 1. SPC560Sx block diagram

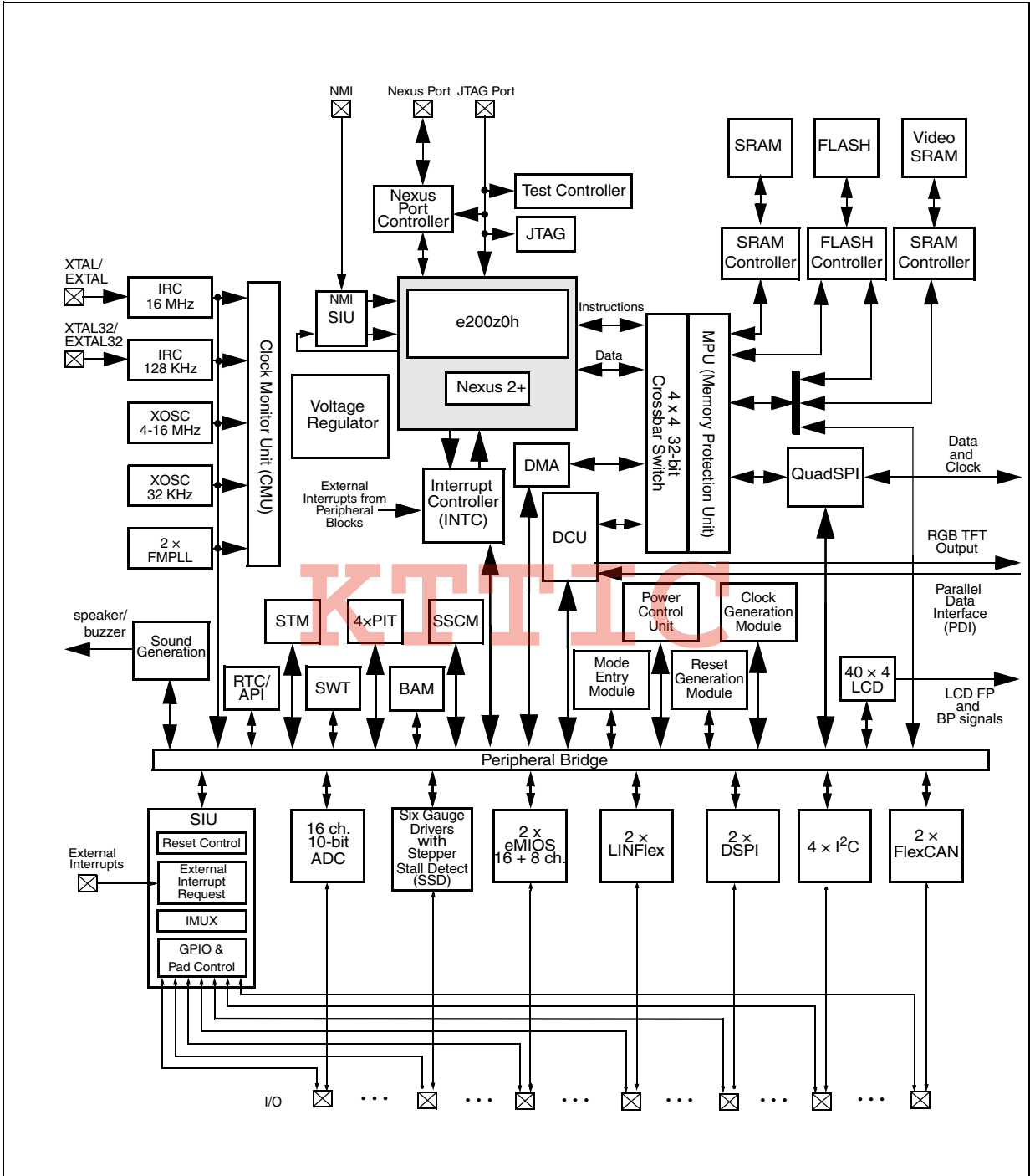

3 Overview of the SPC560Sx Microcontroller

The following sections provide high-level descriptions of the features found in the SPC560Sx family of microcontrollers

3.1 Device Comparison

The following table lists features for devices in the SPC560Sx family.

Table 2. SPC560Sx Family

Feature	SPC560S50	SPC560S60
CPU	e200z0h	
Execution Speed	Static - 64 MHz	
Flash (ECC)	512 KB	1 MB
EEPROM Emulation Block (ECC)	4x16 KB	
RAM (ECC)	48 KB	48 KB
Graphics RAM	No	160 KB
MPU	12 entry 16 channels	
eDMA		
Display Control Unit	No	Yes
Parallel Data Interface	No	Yes
Stepper Motor Controller	6 motors Yes	
Stepper Motor Stall Detect		
Sound Generation	Yes	Using eMIOS
LCD Segment Driver	64x6	40x4
QuadSPI Serial Flash Interface	No	Yes
32 KHz External Crystal Oscillator	Yes	
Real Time Counter and Autonomous Periodic Interrupt	Yes	Yes
Periodic Interrupt Timer	4 ch, 32-bit	
Software Watchdog Timer	Yes	
System Timer Module	4 ch, 32-bit	
Timed I/O ⁽¹⁾	8 ch, 16-bit IC/OC/	
	16 ch, 16-bit OPWM	
ADC ⁽²⁾	16 channels, 10-bit	
CAN (64 Mailboxes)	2 x FlexCAN	2 x FlexCAN
CAN Sampler	Yes	
SCI	2x LINFlex	

Table 2. SPC560Sx Family (continued)

Feature	SPC560S50	SPC560S60
SPI	2 × DSPI	3 ⁽³⁾ × DSPI
I ² C	2	4
GPIO	104	104 / 132
Debug	Nexus 1	Nexus 2+ ⁽⁴⁾
Package	LQFP144	LQFP144 ⁽⁵⁾ LQFP176 LFBGA208 ⁽⁶⁾

1. IC-Input Capture, OC-Output Compare, OPWM-Output Pulse Width Modulation
2. Support for external multiplexer enabling up to 23 channels
3. QuadSPI serial Flash controller can be optionally used as a third DSPI
4. Nexus2+ available on LQFP176 as alternate pin function and on 208LFBGA
5. Not all features are available simultaneously in LQFP144 package option
6. The 208-pin package is not a production package it is available in limited quantities for tool development only

3.2 Feature List

- Single issue, 32-bit PowerPC Book E compliant CPU core complex (e200z0h)
 - Compatible with classic PowerPC instruction set
 - Includes variable length encoding (VLE) instruction set for smaller code size footprint; with the encoding of mixed 16-bit and 32-bit instructions, it is possible to achieve significant code size footprint reduction over conventional Book E compliant code
- On-chip ECC flash memory with flash controller
 - Up to 1 MB primary flash—two 512 KB modules with prefetch buffer and 128-bit data access port
 - 64 KB data flash—separate 4 x 16 KB flash block for EEPROM Emulation with prefetch buffer and 128-bit data access port
- Up to 48 KB on-chip ECC SRAM with SRAM controller
- Up to 160 KB on-chip non-ECC graphics SRAM with SRAM controller (SPC560S60 only)
- Memory protection unit (MPU) with up to 12 region descriptors and 32-byte region granularity to provide basic memory access permission and ensure separation between different codes and data
- Interrupt controller (INTC) with 127 peripheral interrupt sources and eight software interrupts
- Two Frequency Modulated Phase-locked loops (FMPLL)
 - Primary FMPLL provides a 64 MHz system clock
 - Auxiliary FMPLL is available for use as an alternate, modulated or non-modulated clock source to eMIOS modules and as alternate clock to the DCU for pixel clock generation

- Crossbar switch architecture enables concurrent access of peripherals, flash memory or RAM from multiple bus masters (AMBA 2.0 v6 AHB)
- 16-channel enhanced direct memory access controller (eDMA) with multiple transfer request sources using a DMA channel multiplexer
- Boot assist module (BAM) with 8 KB dedicated ROM for embedded boot code supports boot options including download of boot code via a serial link (CAN or SPI)
- Display Control Unit (DCU) designed to generate all signals required to drive a TFT LCD display, blending of data of up to 16 layers, and capable of displaying real time digital video or graphic input and driving up to WQVGA resolution
- Parallel Data Interface for digital video input
- The LCD segment driver module has two configurations allowing a maximum of 160 or 228 LCD segments:
 - Up to 40 front plane drivers and 4 backplane drivers
 - Up to 38 frontplane drivers and 6 backplane drivers
- QuadSPI serial flash memory controller supporting single, dual and quad modes of operation
- Stepper Motor Controller module with high-current drivers for up to six instrument cluster gauges driven in Full Dual H-Bridge configuration
- Stepper motor return-to-zero and stall detection module
- Stepper Motor short circuit detection
- Sound generation and playback utilizing PWM channels and eDMA; supports monotonic and polyphonic sound
- Two enhanced modular Input Output System (eMIOS) modules—one 16-channel and one 8-channel—with input/output channels supporting a range of 16-bit input capture, output compare, and Pulse Width Modulation functions
- 10-bit analog-to-digital converter (ADC) with a maximum conversion time of 1 μ s
 - 16 internal channels
 - Up to 8 external channels
- Two DSPI (Deserial Serial Peripheral Interface) modules for full-duplex, synchronous, communications with external devices.
- QuadSPI module to interface to external serial flash memory or optionally can be configured to function as a third DSPI module (SPC560S60 only)
- Two Local Interconnect Network (LIN) controller modules capable of autonomous message handling (master), autonomous header handling (slave mode), and UART support. Compliant with LIN protocol rev 2.1
- Two Controller Area Network (FlexCAN) modules (compliant with the CAN protocol version 2.0 C) with 64 configurable buffers; the bit rate can be programmed up to 1 Mb/s
- Up to four Inter-integrated circuit (I²C) internal bus controllers with master/slave bus interface
- Up to 132 configurable general purpose pins supporting input and output operations
- Real Time Counter (RTC) with clock source from internal 128 KHz or 16 MHz oscillator supporting autonomous wake-up with 1 ms resolution with maximum timeout of 2 seconds

- Support for Real Time Counter (RTC) with clock source from external 32-KHz crystal oscillator, supporting wake-up with 1 s resolution and maximum timeout of one hour
- RTC optionally clocked by main 4 - 16 MHz external oscillator
- System Timers:
 - 4-channel 32-bit System Timer Module (STM)—included in processor platform
 - Four 4-channel 32-bit Periodic Interrupt Timer (PIT) modules (including ADC trigger)
 - Software watchdog timer
- System Integration Unit (SIU) module to manage resets, external interrupts, GPIO and pad control
- System Status and Configuration Module (SSCM) to provide information for identification of the device, last boot mode, or debug status and provides an entry point for the censorship password mechanism
- Clock Generation Module (CGM) to generate system clock sources and provide a unified register interface, enabling access to all clock sources
- Clock Monitor Unit (CMU) to monitor the integrity of the main crystal oscillator and the PLL and act as a frequency meter, measuring the frequency of one clock source and comparing it to a reference clock
- Mode Entry Module (MEM) to control the device power mode, i.e., RUN, HALT, STOP, or STANDBY, control mode transition sequences, and manage the power control, voltage regulator, clock generation and clock management modules
- Power Control Unit (PCU) to implement standby mode entry/exit and control connections to power domains
- Reset Generation Module (RGM) to manage reset assertion and release to the device at initial power-up
- Nexus development interface (NDI) per IEEE-ISTO 5001-2003 Class Two Plus standard
- Device/board boundary-scan testing supported per Joint Test Action Group (JTAG) of IEEE (IEEE 1149.1)
- On-chip voltage regulator controller for regulating the 3.3-5 V supply voltage down to 1.2 V for core logic (requires external ballast transistor)
- The SPC560Sx microcontrollers are offered in the following packages:^(a)
 - LQFP100^(b) 0.5 mm pitch, 14 mm x 14 mm outline
 - LQFP144, 0.5 mm pitch, 20 mm x 20 mm outline
 - LQFP176, 0.5 mm pitch, 24 mm x 24 mm outline

a. See the device comparison table or orderable parts summary for package offerings for each device in the family.

b. Availability of the 100-pin package has not yet been determined.

3.3 Feature Details

3.3.1 Low Power Operation

SPC560Sx devices are designed for optimized low-power operation and dynamic power management of the core processor and peripherals. Power management features include software-controlled clock gating of peripherals and multiple power domains to minimize leakage in low-power modes.

There are two static low-power modes, STANDBY and STOP, and two dynamic power modes—RUN and HALT. Both low power modes use clock gating to halt the clock for all or part of the device. The STOP mode also uses power gating to automatically turn off the power supply to parts of the device to minimize leakage.

STANDBY mode halts the clock to the entire device and turns off the power to the majority of the chip to offer the lowest power consumption mode.

The device can be awakened from STANDBY mode via from any of up to 18 I/O pins, a reset or from a periodic wake-up using a low power oscillator. If required, it is possible to enable the internal 16 MHz or 128 KHz RC oscillator, the external 4 - 16 MHz oscillator or the external 32 KHz oscillator.

In STANDBY mode the contents of the cores, on-chip peripheral registers and potentially some of the volatile memory are lost.

- STANDBY2 mode retains the full contents of the on-chip SRAM but the content of the graphics SRAM is lost.
- STANDBY1 mode retains 8 KB of the on-chip SRAM but the content of the graphics SRAM is lost.

STOP mode maintains power to the entire device allowing the retention of all on-chip registers and memory, and providing a faster recovery low power mode than the lowest STANDBY mode. There is no need to reconfigure the device before executing code. The clocks to the core and peripherals are halted and can be optionally stopped to the oscillator or PLL at the expense of a slower start-up time.

STOP is entered from RUN mode only. Wake-up from STOP mode is triggered by an external event or by the internal periodic wake-up, if enabled.

RUN modes are the main operating mode where the entire device can be powered and clocked and from which most processing activity is done. Four dynamic RUN modes are supported—RUN0 - RUN3. The ability to configure and select different RUN modes enables different clocks and power configurations to be supported with respect to each other and to allow switching between different operating conditions. The necessary peripherals, clock sources, clock speed and system clock prescalers can be independently configured for each of the four RUN modes of the device.

HALT mode is a reduced activity, low power mode intended for moderate periods of lower processing activity. In this mode the core system clocks are stopped but user-selected peripheral tasks can continue to run. It can be configured to provide more efficient power management features (switch-off PLL, flash memory, main regulator, etc.) at the cost of longer wake up latency. The system returns to RUN mode as soon as an event or interrupt is pending.

The following table summarizes the operating modes of SPC560Sx devices.

Table 3. Operating Mode Summary⁽¹⁾

Operating Modes	SOC Features					Clock Sources						Periodic Wake-up	Wake-up input	VREG mode	Wake-up Time ⁽²⁾						
	Core	Peripherals	Flash	RAM	Graphics RAM	Main PLL	Auxiliary PLL	16MHz IRC	X OSC	128KHz IRC	32KHz X OSC				VREG start-up	IRC Wake-up	Flash Recovery	OSC Stabilization	PLL Lock	S/W Reconfig	Mode switch over
RUN	On	OP	OP	On	On	OP	OP	On	OP	On	OP	—	—	FP	—	—	—	—	—	—	—
HALT	CG	OP	OP	On	On	OP	OP	On	OP	On	OP	OP	OP	FP	—	—	—	—	—	—	TB D
STOP	CG	CG	CG	On	On	CG	CG	OP	OP	On	OP	OP	OP	LP	50 μs	4 μs	20 μs	1 ms	200 μs	—	24 μs
STANDBY	Off	Off ⁽³⁾	Off	CG ⁽⁴⁾	Off	Off	Off	OP	OP	OP	OP	OP	OP	LP	50 μs	8 μs	100 μs	1 ms	200 μs	Var	28 μs
	Off	Off	Off	8K ⁽⁵⁾	Off	Off	Off	OP	OP	OP	OP	OP	OP	LP	50 μs	8 μs	100 μs	1 ms	200 μs	Var	28 μs
POR															500 μs	8 μs	100 μs	1 ms	200 μs		BAM

1. Table Key:

On- Powered and clocked

OP- Optionally configurable to be enabled or disabled (clock gated)

CG- Clock Gated, Powered but clock stopped

Off- Powered off and clock gated

FP- VREG Full Performance mode

LP- VREG Low Power mode, reduced output capability of VREG but lower power consumption

Var- Variable duration, based on the required reconfiguration and execution clock speed

BAM- Boot Assist Module Software and Hardware used for device start-up and configuration

2. A high level summary of some key durations that need to be considered when recovering from low power modes. This does not account for all durations at wake up. Other delays will be necessary to consider including, but not limited to the external supply start-up time.

IRC Wake-up time must not be added to the overall wake-up time as it starts in parallel with the VREG.

All other wake-up times must be added to determine the total start-up time

3. The LCD can optionally be kept running while the device is in STANDBY mode

4. All of the RAM contents is retained, but not accessible in STANDBY mode

5. 8K of the RAM contents is retained, but not accessible in STANDBY mode

Additional notes on low power operation:

- Fast wake-up using the on-chip 16 MHz internal RC oscillator allows rapid execution from RAM on exit from low power modes
- The 16 MHz internal RC oscillator supports low speed code execution and clocking of peripherals when it is selected as the system clock and can also be used as the PLL input clock source to provide fast start-up without the external oscillator delay
- SPC560Sx devices include an internal voltage regulator that includes the following features:
 - Regulates input to generate all internal supplies
 - Manages power gating
 - Low power regulators support operation when in STOP and STANDBY modes to minimize power consumption
 - Startup on-chip regulators in <50µs for rapid exit of STOP and STANDBY modes
 - Low voltage detection on main supply and 1.2 V regulated supplies.

3.3.2 e200z0h Core Processor

The e200z0h processor is similar to other processors in the e200zx series but supports only the VLE instruction set and does not include the signal processing extension for DSP applications or a floating point unit.

The e200z0h has all the features of the e200z0 plus:

- Branch acceleration using Branch Target Buffer (BTB)
- Supports independent instruction and data accesses to different memory subsystems, such as SRAM and Flash memory via independent Instruction and Data BIUs

The e200z0h processor uses a four stage in-order pipeline for instruction execution. The Instruction Fetch (stage 1), Instruction Decode/Register file Read/Effective Address Calculation (stage 2), Execute/Memory Access (stage 3), and Register Writeback (stage 4) stages operate in an overlapped fashion, allowing single clock instruction execution for most instructions.

The integer execution unit consists of a 32-bit Arithmetic Unit (AU), a Logic Unit (LU), a 32-bit Barrel shifter (Shifter), a Mask-Insertion Unit (MIU), a Condition Register manipulation Unit (CRU), a Count-Leading-Zeros unit (CLZ), an 8x32 Hardware Multiplier array, result feed-forward hardware, and a hardware divider.

Most arithmetic and logical operations are executed in a single cycle with the exception of the divide and multiply instructions. A Count-Leading-Zeros unit operates in a single clock cycle. The Instruction Unit contains a PC incremter and a dedicated Branch Address adder to minimize delays during change of flow operations. Branch target prefetching from the BTB is performed to accelerate certain taken branches. Sequential prefetching is performed to ensure a supply of instructions into the execution pipeline. Branch target prefetching is performed to accelerate taken branches. Prefetched instructions are placed into an instruction buffer capable of holding four instructions.

Conditional branches not taken execute in a single clock. Branches with successful target prefetching have an effective execution time of one clock on e200z0h. All other taken branches have an execution time of two clocks.

Memory load and store operations are provided for byte, halfword, and word (32-bit) data with automatic zero or sign extension of byte and halfword load data as well as optional byte reversal of data. These instructions can be pipelined to allow effective single cycle

throughput. Load and store multiple word instructions allow low overhead context save and restore operations. The load/store unit contains a dedicated effective address adder to allow effective address generation to be optimized. Also, a load-to-use dependency does not incur any pipeline bubbles for most cases.

The Condition Register unit supports the condition register (CR) and condition register operations defined by the PowerPC architecture. The condition register consists of eight 4-bit fields that reflect the results of certain operations, such as move, integer and floating-point compare, arithmetic, and logical instructions, and provide a mechanism for testing and branching.

Vectored and autovectored interrupts are supported. Hardware vectored interrupt support is provided to allow multiple interrupt sources to have unique interrupt handlers invoked with no software overhead.

The CPU includes support for Variable Length Encoding (VLE) instruction enhancements. This allows the classic PowerPC instruction set to be represented by a modified instruction set made up from a mixture of 16-bit and 32-bit instructions. This results in a significantly smaller code size footprint without affecting performance noticeably.

The CPU core is enhanced by an additional interrupt source—Non Maskable Interrupt. This interrupt source is routed directly from package pins, via edge detection logic in the SIU to the CPU, bypassing the Interrupt Controller completely. Once the edge detection logic is programmed, it can not be disabled, except by reset. The Non Maskable Interrupt is, as the name suggests, completely un-maskable and when asserted will always result in the immediate execution of the respective interrupt service routine. The Non maskable interrupt is not guaranteed to be recoverable.

The CPU core has an additional 'Wait for Interrupt' instruction that is used in conjunction with low power STOP mode. When Low Power Stop mode is selected, this instruction is executed to allow the system clock to be stopped. An external interrupt source or the system wake-up timer is used to restart the system clock and allow the CPU to service the interrupt.

Additional features include:

- Load/store unit
 - 1-cycle load latency
 - Misaligned access support
 - No load-to-use pipeline bubbles
- Thirty-two 32-bit general purpose registers (GPRs)
- Separate instruction bus and load/store bus Harvard architecture
- Reservation instructions for implementing read-modify-write constructs
- Multi-cycle divide (divw) and load multiple (lmw) store multiple (smw) multiple class instructions, can be interrupted to prevent increases in interrupt latency
- Extensive system development support through Nexus debug port

3.3.3 Crossbar

The XBAR multi-port crossbar switch supports simultaneous connections between four master ports and four slave ports. The crossbar supports a 32-bit address bus width and a 32-bit data bus width.

The crossbar allows four concurrent transactions to occur from any master port to any slave port but one of those transfers must be an instruction fetch from internal flash. If a slave port

is simultaneously requested by more than one master port, arbitration logic selects the higher priority master and grants it ownership of the slave port. All other masters requesting that slave port are stalled until the higher priority master completes its transactions. Requesting masters having equal priority are granted access to a slave port in round-robin fashion, based upon the ID of the last master to be granted access.

The crossbar provides the following features:

- Four master ports:
 - e200z0h core instruction port
 - e200z0h core complex load/store data port
 - eDMA controller
 - Display control unit
- Four slave ports:
 - One flash port dedicated to the CPU
 - Platform SRAM
 - QuadSPI serial flash controller
 - One slave port combining:
 - Flash port dedicated to the Display Control Unit and eDMA module
 - Graphics SRAM
 - Peripheral bridge
- 32-bit internal address bus, 32-bit internal data bus

3.3.4 eDMA

The enhanced direct memory access (eDMA) module is a controller capable of performing complex data movements via 16 programmable channels, with minimal intervention from the host processor. The hardware micro architecture includes a DMA engine which performs source and destination address calculations, and the actual data movement operations, along with an SRAM-based memory containing the transfer control descriptors (TCD) for the channels. This implementation is utilized to minimize the overall block size. The eDMA module provides the following features:

- 16 channels support independent 8-, 16- or 32-bit single value or block transfers
- Supports variable sized queues and circular queues
- Source and destination address registers are independently configured to post-increment or remain constant
- Each transfer is initiated by a peripheral, CPU, periodic timer interrupt or eDMA channel request
- Each DMA channel can optionally send an interrupt request to the CPU on completion of a single value or block transfer
- DMA transfers possible between system memories, QuadSPI, DSPs, I²C, ADC, eMIOS and General Purpose I/Os (GPIOs)
- Programmable DMA Channel Mux allows assignment of any DMA source to any available DMA channel with up to a total of 64 potential request sources.

3.3.5 Inter IC Communications Module (I²C)

The I²C module features the following:

- Up to four I²C modules supported
- Two-wire bi-directional serial bus for on-board communications
- Compatibility with I²C bus standard
- Multimaster operation
- Software-programmable for one of 256 different serial clock frequencies
- Software-selectable acknowledge bit
- Interrupt-driven, byte-by-byte data transfer
- Arbitration-lost interrupt with automatic mode switching from master to slave
- Calling address identification interrupt
- Start and stop signal generation/detection
- Repeated START signal generation
- Acknowledge bit generation/detection
- Bus-busy detection

3.3.6 Interrupt Controller

The INTC (interrupt controller) provides priority-based preemptive scheduling of interrupt requests, suitable for statically scheduled hard real-time systems.

For high priority interrupt requests, the time from the assertion of the interrupt request from the peripheral to when the processor is executing the interrupt service routine (ISR) has been minimized. The INTC provides a unique vector for each interrupt request source for quick determination of which ISR needs to be executed. It also provides an ample number of priorities so that lower priority ISRs do not delay the execution of higher priority ISRs. To allow the appropriate priorities for each source of interrupt request, the priority of each interrupt request is software configurable.

When multiple tasks share a resource, coherent accesses to that resource need to be supported. The INTC supports the priority ceiling protocol for coherent accesses. By providing a modifiable priority mask, the priority can be raised temporarily so that all tasks which share the resource can not preempt each other.

Multiple processors can assert interrupt requests to each other through software settable interrupt requests. These same software settable interrupt requests also can be used to break the work involved in servicing an interrupt request into a high priority portion and a low priority portion. The high priority portion is initiated by a peripheral interrupt request, but then the ISR asserts a software settable interrupt request to finish the servicing in a lower priority ISR. Therefore these software settable interrupt requests can be used instead of the peripheral ISR scheduling a task through the RTOS. The INTC provides the following features:

- Unique 9-bit vector for each of the possible 128 separate interrupt sources
- Eight software triggerable interrupt sources
- 16 priority levels with fixed hardware arbitration within priority levels for each interrupt source

- Ability to modify the ISR or task priority.
 - Modifying the priority can be used to implement the Priority Ceiling Protocol for accessing shared resources.
- External non maskable interrupt directly accessing the main core critical interrupt mechanism
- 32 external interrupts

3.3.7 QuadSPI Serial Flash Controller

The QuadSPI module enables use of external serial flash memories supporting single, dual and quad modes of operation. It features the following:

- Memory mapping of external serial flash
- Automatic serial flash read command generation by CPU, DMA or DCU read access on AHB bus
- Supports single, dual and quad serial flash read commands
- Flexible buffering scheme to maximize read bandwidth of serial flash
- Maximum frequency 64MHz
- ‘Legacy’ mode allowing QuadSPI to be used as a standard DSPI (no DSI or CSI mode)

3.3.8 System Integration Unit (SIU)

The SIU controls MCU reset configuration, pad configuration, external interrupt, general purpose I/O (GPIO), internal peripheral multiplexing, and the system reset operation.

The GPIO features the following:

- Up to four levels of internal pin multiplexing, allowing exceptional flexibility in the allocation of device functions for each package
- Centralized general purpose input output (GPIO) control of up to 132 input/output pins (package dependent)
- All GPIO pins can be independently configured to support pull-up, pull down, or no pull
- Reading and writing to GPIO supported both as individual pins and 16-bit wide ports
- All peripheral pins can be alternatively configured as both general purpose input or output pins except ADC channels which support alternative configuration as general purpose inputs
- Direct readback of the pin value supported on all digital output pins through the SIU
- Configurable digital input filter that can be applied to up to 14 general purpose input pins for noise elimination on external interrupts
- Register configuration protected against change with soft lock for temporary guard or hard lock to prevent modification until next reset.

3.3.9 Flash

The SPC560Sx microcontroller has the following flash memory features:

- Up to 1 MB of burst Flash memory
 - Typical Flash access time: 0 wait-state for buffer hits, 2 wait-states for page buffer miss at 64 MHz
 - Two 4 x 128-bit page buffers with programmable prefetch control

- One set of page buffers can be allocated for code-only, fixed partitions of code and data, all available for any access
- One set of page buffers allocated to Display Controller Unit and the eDMA
- 64-bit ECC with single-bit correction, double-bit detection for data integrity
- 64 KB data flash—separate 4 x 16 KB flash block for EEPROM Emulation with prefetch buffer and 128-bit data access port
- Small block flash arrangement to support features such as boot block, operating system block.
- Hardware managed Flash writes, erase and verify sequence
- Censorship protection scheme to prevent Flash content visibility
- Separate dedicated 64 KB data flash for EEPROM emulation
 - Four erase sectors each containing 16 KB of memory
 - Offers Read-While-Write functionality from main program space
 - Same data retention and program erase specification as main program flash array

3.3.10 SRAM

The SPC560Sx microcontrollers have up to 48 KB general-purpose on-chip SRAM with the following features:

- Typical SRAM access time: 0 wait-state for reads and 32-bit writes; 1 wait-state for 8- and 16-bit writes if back to back with a read to same memory block
- 32-bit ECC with single-bit correction, double bit detection for data integrity
- Supports byte (8-bit), half word (16-bit), and word (32-bit) writes for optimal use of memory
- User transparent ECC encoding and decoding for byte, half word, and word accesses
- Separate internal power domain applied to full SRAM block, 8Kbytes SRAM block during STANDBY modes to retain contents during low power mode.

3.3.11 On-chip Graphics SRAM

The SPC560S60 microcontroller has 160 KB on-chip graphics SRAM with the following features:

- Usable as general purpose SRAM
- Typical SRAM access time: 0 wait-state for reads and 32-bit writes
- Supports byte (8-bit), half word (16-bit), and word (32-bit) writes for optimal use of memory

3.3.12 Memory Protection Unit (MPU)

The MPU features the following:

- Twelve region descriptors for per master protection
- Start and end address defined with 32-byte granularity
- Overlapping regions supported
- Protection attributes can optionally include process ID
- Protection offered for 3 concurrent read ports
- Read and write attributes for all masters
- Execute and supervisor/user mode attributes for processor masters

3.3.13 Boot Assist Module (BAM)

The BAM is a block of read-only memory that is programmed once by STMicroelectronics. The BAM program is executed every time the MCU is powered-on or reset in normal mode. The BAM supports different modes of booting. They are:

- Booting from internal flash memory
- Serial boot loading (A program is downloaded into RAM via FlexCAN or LINFlex and then executed)
- Booting from external memory

Additionally the BAM:

- Enables and manages the transition of the MCU from reset to user code execution
- Configures device for serial bootload
- Enables multiple bootcode starting locations out of reset through implementation of search for valid Reset Configuration Halfword
- Enables or disables software watchdog timer out of reset through BAM read of Reset Configuration Halfword option bit

3.3.14 eMIOS

SPC560Sx microcontrollers have two enhanced modular Input Output System (eMIOS) modules—one with 16 channels and one with 8—with input/output channels supporting a range of 16-bit input capture, output compare, and Pulse Width Modulation functions.

The modules are configurable and can implement 8-channel, 16-bit input capture/output compare or 16-channel, 16-bit output pulse width modulation/input compare/output compare. Up to five additional channels are configurable as modulus counters.

eMIOS other features include:

- Selectable clock source from main FMPLL, auxiliary FMPLL, external 4 - 16 MHz oscillator or 16 MHz Internal RC oscillator
- Timed I/O channels with 16-bit counter resolution
- Buffered updates
- Support for shifted PWM outputs to minimize occurrence of concurrent edges
- Edge aligned output pulse width modulation
 - Programmable pulse period and duty cycle
 - Supports 0% and 100% duty cycle
 - Shared or independent time bases
- Programmable phase shift between channels
- Selectable combination of pairs of eMIOS outputs to support sound generation
- DMA transfer support
- Selectable clock source from the primary FMPLL, auxiliary FMPLL, external 4-16 Mhz oscillator or the 16 MHz internal RC oscillator.

The channel configuration options for the 16-channel eMIOS module are summarized in [Table 4](#).

Table 4. 16-Channel eMIOS Module Channel Configuration

Channel Mode	Channel Number				
	8	9-15	16	17-22	23
	IC/OC Counter	IC/OC Counter	PWM Counter	PWM Counter	PWM Counter
General Purpose Input/Output	X	X	X	X	X
Single Action Input Capture	X	X	X	X	X
Single Action Output Compare	X	X	X	X	X
Modulus Counter Buffered ⁽¹⁾	X		X		X
Output Pulse Width and Frequency Modulation Buffered			X	X	X
Output Pulse Width Modulation Buffered			X	X	X

1. Modulus up and down counters to support driving local and global counter busses

The channel configuration options for the 8-channel eMIOS module are summarized in [Table 5](#).

Table 5. 8-Channel eMIOS Module Channel Configuration

Channel Mode	Channel Number		
	16	17-22	23
	PWM Counter	PWM	PWM Counter
General Purpose Input/Output	X	X	X
Single Action Input Capture	X	X	X
Single Action Output Compare	X	X	X
Modulus Counter Buffered ⁽¹⁾	X		X
Output Pulse Width and Frequency Modulation Buffered	X	X	X
Output Pulse Width Modulation Buffered	X	X	X

1. Modulus up and down counters to support driving local and global counter busses

3.3.15 Analog to Digital Converter Module (ADC)

The ADC features the following:

- 10-bit A/D resolution
- 0 to 5 V common mode conversion range
- Supports conversions speeds of up to 1μs
- 16 internal and 8 external channels support
- Up to 16 single-ended inputs channels
 - 10 channels configured as input only pins
 - 10-bit ± 2 counts accuracy (TUE)
 - 6 channels configured to have alternate function as general purpose input/output pins

- 10-bit \pm 3 counts accuracy (TUE)
- External multiplexer support to increase up to 23 channels
 - Automatic 1 \times 8 multiplexer control
 - External multiplexer connected to a dedicated input channel
 - Shared register between the 8 external channels
- Result register available for every non-multiplexed channel
- Configurable Left or Right aligned result format
- Supports for one-shot, scan and injection conversion modes
- Injection mode status bit implemented on adjacent 16-bit register for each result
 - Supports Access to Result and injection status with single 32-bit read
- Independently enabling of function for channels:
 - Pre-sampling
 - Offset error cancellation
 - Offset Refresh
- Conversion Triggering support
 - Internal conversion triggering from periodic interrupt timer (PIT)
- Four configurable analog comparator channels offering range comparison with triggered alarm
 - Greater than
 - Less than
 - Out of range
- All unused analog pins available as general purpose input pins
- Selected unused analog pins available as general purpose pins
- Power Down mode
- Optional support for DMA transfer of results

3.3.16 Deserial Serial Peripheral Interface (DSPI)

The deserial serial peripheral interface (DSPI) modules provide a synchronous serial interface for communication between the SPC560Sx MCU and external devices.

The DSPI features the following:

- Up to two DSPI modules
- Full duplex, synchronous transfers
- Master or slave operation
- Programmable master bit rates
- Programmable clock polarity and phase
- End-of-transmission interrupt flag
- Programmable transfer baud rate
- Programmable data frames from 4 to 16 bits
- Up to six chip select lines available, depending on package and pin multiplexing, enable 64 external devices to be selected using external muxing from a single DSPI
- Eight clock and transfer attributes registers
- Chip select strobe available as alternate function on one of the chip select pins for de-glitching
- FIFOs for buffering up to 4 transfers on the transmit and receive side
- General purpose I/O functionality on pins when not used for SPI
- Queueing operation possible through use of eDMA

3.3.17 FlexCAN

The SPC560Sx MCU contains two controller area network (FlexCAN) modules. The FlexCAN module is a communication controller implementing the CAN protocol according to Bosch Specification version 2.0B. The CAN protocol was designed to be used primarily as a vehicle serial data bus, meeting the specific requirements of this field: real-time processing, reliable operation in the EMI environment of a vehicle, cost-effectiveness and required bandwidth.

The FlexCan modules offer the following:

- Compliant with CAN protocol specification, Version 2.0B active
- 64 mailboxes, each configurable as transmit or receive
 - Mailboxes configurable while module remains synchronized to CAN bus
- Transmit features
 - Supports configuration of multiple mailboxes to form message queues of scalable depth
 - Arbitration scheme according to message ID or message buffer number
 - Internal arbitration to guarantee no inner or outer priority inversion
 - Transmit abort procedure and notification
- Receive features
 - Individual programmable filters for each mailbox
 - 8 mailboxes configurable as a 6-entry receive FIFO
 - 8 programmable acceptance filters for receive FIFO
- Programmable clock source
 - System clock
 - Direct oscillator clock to avoid PLL jitter
- Listen only mode capabilities
- CAN Sampler
 - Can catch the 1st message sent on the CAN network while the SPC560Sx is stopped. This guarantees a clean startup of the system without missing messages on the CAN network.
 - The CAN sampler is connected to one of the CAN RX pins.

3.3.18 Serial Communication Interface Module (LINFlex)

The SPC560Sx devices include up to two LINFlex modules and support for LIN Master mode, LIN Slave mode and UART mode. The modules are LIN state machine compliant to the LIN 1.3 and 2.0 and 2.1 Specifications and handle LIN frame transmission and reception without CPU intervention.

Other features include:

- Autonomous LIN frame handling
- Message buffer to store identifier and up to eight data bytes
- Supports message length of up to 64 bytes
- Detection and flagging of LIN errors
- Sync field; Delimiter; ID parity; Bit, Framing; Checksum and Timeout errors
- Classic or extended checksum calculation
- Configurable Break duration of up to 36-bit times
- Programmable Baud rate prescalers (13-bit mantissa, 4-bit fractional)
- Diagnostic features
 - Loop back
 - Self Test
 - LIN bus stuck dominant detection
- Interrupt driven operation with 16 interrupt sources
- LIN slave mode features
 - Autonomous LIN header handling
 - Autonomous LIN response handling
 - Discarding of irrelevant LIN responses using up to 16 ID filters
- UART mode
 - Full-duplex operation
 - Standard non return-to-zero (NRZ) mark/space format
 - Data buffers with 4-byte receive, 4-byte transmit
 - Configurable word length (8-bit or 9-bit words)
 - Error detection and flagging
 - Parity, noise and framing errors
 - Interrupt driven operation with 4 interrupts sources
 - Separate transmitter and receiver CPU interrupt sources
 - 16-bit programmable baud-rate modulus counter and 16-bit fractional
 - Two receiver wake-up methods

3.3.19 System Clocks and Clock Generation Modules

The system clock on the SPC560Sx can be derived from an external oscillator, an on-chip FMPLL, or the internal 16 MHz oscillator.

- The source system clock frequency can be changed via an on-chip programmable clock divider ($\div 1$ to $\div 32$).
- Additional programmable peripheral bus clock divider ratio ($\div 1$ to $\div 15$)
- The SPC560Sx has two on-chip FMPLLs—the primary module and an auxiliary module.
 - Each features the following:
 - Input clock frequency from 4 MHz to 16 MHz
 - Lock detect circuitry continuously monitors lock status
 - Loss Of Clock (LOC) detection for reference and feedback clocks

- On-chip loop filter (for improved electromagnetic interference performance and reduction of number of external components required)
 - Support for Frequency ramping from PLL
- The primary FMPLL module is for use as a system clock source. The auxiliary FMPLL is available for use as an alternate, modulated or non-modulated clock source to eMIOS modules and as alternate clock to the DCU for pixel clock generation.
- The main oscillator provides the following features:
 - Input frequency range 4 MHz - 16 MHz
 - Square-wave input mode
 - Oscillator input mode 3.3 V (5.0 V)
 - Automatic level control
 - PLL reference
- SPC560Sx includes a 32 KHz low power external oscillator for slow execution, low power, and Real Time Clock
- Dedicated internal 128 KHz RC oscillator for low power mode operation and self wake-up
 - $\pm 10\%$ accuracy across voltage and temperature (after factory trimming)
 - Trimming registers to support improved accuracy with in-application calibration
- Dedicated 16 MHz internal RC oscillator
 - Used as default clock source out of reset
 - Provides a clock for rapid start-up from low power modes
 - Provides a back-up clock in the event of PLL or External Oscillator clock failure
 - Offers an independent clock source for the Watchdog timer
 - $\pm 5\%$ accuracy across voltage and temperature (after factory trimming)
 - Trimming registers to support frequency adjustment with in-application calibration

3.3.20 Periodic Interrupt Timer Module (PIT)

The PIT features the following:

- Four general purpose interrupt timers
- Up to two dedicated interrupt timers for triggering ADC conversions
- 32-bit counter resolution
- Clocked by system clock frequency
- 32-bit counter for Real Time Interrupt, clocked from main external oscillator

3.3.21 Real Time Counter (RTC)

Real Timer Counter supports wake-up from Low Power modes or Real Time Clock generation

- Configurable resolution for different timeout periods
 - 1 s resolution for >1 hour period
 - 1 ms resolution for 2 second period
- Selectable clock sources from external 32 KHz crystal, external 4-16MHz crystal, internal 128 KHz RC oscillator or divided internal 16 MHz RC oscillator

3.3.22 Software Timer Module (STM)

The System Timer Module (STM) is a 32-bit timer designed to support commonly required system and application software timing functions. The STM includes a 32-bit up counter and four 32-bit compare channels with a separate interrupt source for each channel. The counter is driven by the system clock divided by an 8-bit prescale value (1 to 256).

- One 32-bit up counter with 8-bit prescaler
- Four 32-bit compare channels
- Independent interrupt source for each channel
- Counter can be stopped in debug mode

3.3.23 Software Watchdog Timer (SWT)

The Watchdog features the following:

- Watchdog supporting software activation or enabled out of Reset
- Supports normal or windowed mode
- Watchdog timer value writable once after reset
- Watchdog supports optional halting during low power modes
- Configurable response on timeout: reset, interrupt, or interrupt followed by reset
- Selectable clock source for main system clock or internal 16MHz RC oscillator clock

3.3.24 Display Control Unit (DCU)

The DCU is a display controller designed to drive TFT LCD displays capable of driving up to WQVGA resolution screens with 16 layers and 4 planes with real time alpha-blending.

The DCU generates all the necessary signals required to drive the display: up to 24-bit RGB data bus, Pixel Clock, Data Enable, Horizontal-Sync and Vertical-Sync.

Internal memory resource of the SPC560Sx allows to easily handle complex graphics contents (pictures, icons, languages, fonts) on a color TFT panel in up to Wide Quarter Video Graphics Array (WQVGA) sizes. All the data fetches from internal and/or external memory are performed by the internal four-channel DMA of the DCU providing a high speed/low latency access to the system backbone.

Control Descriptors (CDs) associated with each layer enable effective merging of different resolutions into one plane to optimize use of internal memory buffers. A layer may be constructed from graphic content of various resolutions including 1bpp, 2bpp, 4bpp, 8bpp, 16bpp, 24bpp and 24bpp+alpha. The ability of the DCU to handle input data in resolutions as low as 1bpp, 2bpp and 4bpp enables a highly efficient use of internal memory resources of the SPC560Sx. A special tiled mode can be enabled on any of the 16 layers to repeat a pattern optimizing graphic memory usage.

A hardware cursor can be managed independently of the layers at blending level increasing the efficient use of the internal DCU resources.

To secure the content of all critical information to be displayed, a safety mode can be activated to check the integrity of critical data along the whole system data path from the memory to the TFT pads.

The DCU features the following:

- Display color depth: up to 24 bpp
- Generation of all RGB and control signals for TFT
- Four-plane blending
- Maximum number of Input Layers: 16 (fixed priority)
- Dynamic Look-Up-Table (Color and Gamma Look-Up)
- α -blending range: up to 256 levels
- Transparency Mode
- Gamma Correction
- Tiled mode on all the layers
- Hardware Cursor
- Critical display content integrity monitoring for Functional Safety support
- Internal Direct Memory Access (DMA) module to transfer data from internal and / or external memory.

3.3.25 Parallel Data Interface (PDI)

The PDI is a digital interface used to receive external digital video or graphic content into the DCU.

The PDI input is directly injected into the DCU background plane FIFO. When the PDI is activated, all the DCU synchronization is extracted from the external video stream to guarantee the synchronization of the two video sources.

The PDI can be used to:

- Connect a Video Camera output directly to the PDI
- Connect a secondary display driver as slave with a minimum of extra cost
- Connect a device gathering various Video sources
- Provide flexibility to allow the DCU to be used in slave mode (external synchronization)

The PDI features the following:

- Supported color modes:
 - 8-bit mono
 - 8-bit color multiplexed
 - RGB565
 - 16-bit/18-bit RAW color
- Supported synchronization modes:
 - embedded ITU-R BT.656-4 (RGB565 mode 2)
 - HSYNC, VSYNC
 - Data Enable
- Direct interface with DCU background plane FIFO
- Synchronization generation for the DCU

3.3.26 Liquid Crystal Display (LCD) Driver

The LCD driver module has two configurations allowing a maximum of 160 or 228 LCD segments:

- Up to 40 frontplane drivers and 4 backplane drivers
- Up to 38 frontplane drivers and 6 backplane drivers

Each segment is controlled and can be masked by a corresponding bit in the LCD RAM

Four to six multiplex modes (1/1, 1/2, 1/3, 1/4, 1/5, 1/6 duty), and three bias (1/1, 1/2, 1/3) methods are available. All frontplane and backplane pins can be multiplexed with other Port functions

The LCD Driver module features the following:

- Programmable frame clock generator from different clock sources
 - System clock, Internal RC Oscillator
- Programmable bias voltage level selector
- On Chip generation of all output voltage levels
 - LCD voltage reference taken from main 5V supply
- LCD RAM – contains the data to be displayed on the LCD
 - Data can be read from or written to the display RAM at any time
- End of Frame interrupt:
 - To optimize the refresh of the data without visual artefact
 - Selectable number of frames between each interrupt
- Contrast adjustment using programmable internal voltage reference
- Remapping capability of 4 or 6 backplanes with frontplanes;
 - To increase pin selection flexibility
- In low power modes the LCD operation can be suspended under software control. The LCD can also operate in low power modes, clocked by the internal 128 KHz IRC or external 32 kHz crystal oscillator
- Selectable output current boost during transitions

3.3.27 Motor Control (MC)

The Motor Control module is a PWM motor controller suitable to drive instruments in a cluster configuration or any other loads requiring a PWM signal. The motor controller has twelve PWM channels associated with two pins each (24 pins in total).

The Motor Control module includes the following features:

- 10/11-bit PWM counter
- 11-bit resolution with selectable PWM dithering function
- Left, right, or center aligned PWM
- Output slew rate control
- Output Short Circuit Detection

This module is suited for, but not limited to, driving small stepper and air core motors used in instrumentation applications. This module can be used for other motor control or PWM applications that match the frequency, resolution, and output drive capabilities of the module.

3.3.28 Stepper Motor Stall Detect (SSD)

The stepper stall detector (SSD) module provides a circuit to measure and integrate the induced voltage on the non-driven coil of a stepper motor using full steps when the gauge pointer is returning to zero (RTZ).

The SSD module features the following:

- Programmable full step state
- Programmable integration polarity
- Blanking (recirculation) state
- 16-bit integration accumulator register
- 16-bit modulus down counter with interrupt

3.3.29 Sound Generation

The sound generation module has two modes of operation:

- Amplitude modulated PWM mode for low cost buzzers using any two eMIOS channels:
 - Monophonic signal with amplitude control
 - 8-bit amplitude resolution
 - Ability to mix any two eMIOS channels.
 - Requires simple external RC lowpass filter
- Digital sample mode for higher quality sound using one eMIOS channel and eDMA
 - Up to 10-bit audio amplitude resolution
 - Polyphonic sound synthesis
 - Playback of sample based waveforms
 - Text-2-speech possibility
 - Requires external lowpass filter

3.3.30 IEEE 1149.1 JTAG Controller (JTAGC)

JTAGC features the following:

- Backward compatible to standard JTAG IEEE 1149.1-2001 test access port (TAP) interface
- Support for boundary scan testing

3.3.31 Nexus Development Interface (NDI)

Nexus features the following:

- Per IEEE-ISTO 5001-2003
- Nexus 2 Plus features supported
 - Static debug
 - Watchpoint messaging
 - Ownership trace messaging
 - Program trace messaging
 - Real time read/write of any internally memory mapped resources through JTAG pins
 - Overrun control, which selects whether to stall before Nexus overruns or keep executing and allow overwrite of information
 - Watchpoint triggering, watchpoint triggers program tracing
- Configured via the IEEE 1149.1 (JTAG) port
- Nexus Auxiliary port supported on the LQFP176 and 208-PIN BGA package FOR DEVELOPMENT ONLY
 - Narrow Auxiliary Nexus port supporting support trace, with TWO MDO pins
 - Wide Auxiliary Nexus port supporting higher bandwidth trace, with 4 MDO pins

KTTIC

4 Application Examples

4.1 Instrument Cluster with TFT Display

Figure 2 outlines an Instrument Cluster application supporting a color TFT display built around the SPC560S60 microcontroller. With its internal Display Control Unit, it is capable of directly driving up to a Wide Quarter VGA (WQVGA) color TFT display using internal memory resources only. Further, it supports a Parallel Digital Interface (PDI) for cost effective, simple video input. Increased graphical content can be achieved using external serial flash memory and can be further extended with external flash and/or SRAM connected to the serial peripheral interface (QuadSPI).

Figure 2. Instrument Cluster using the SPC560S60 Microcontroller

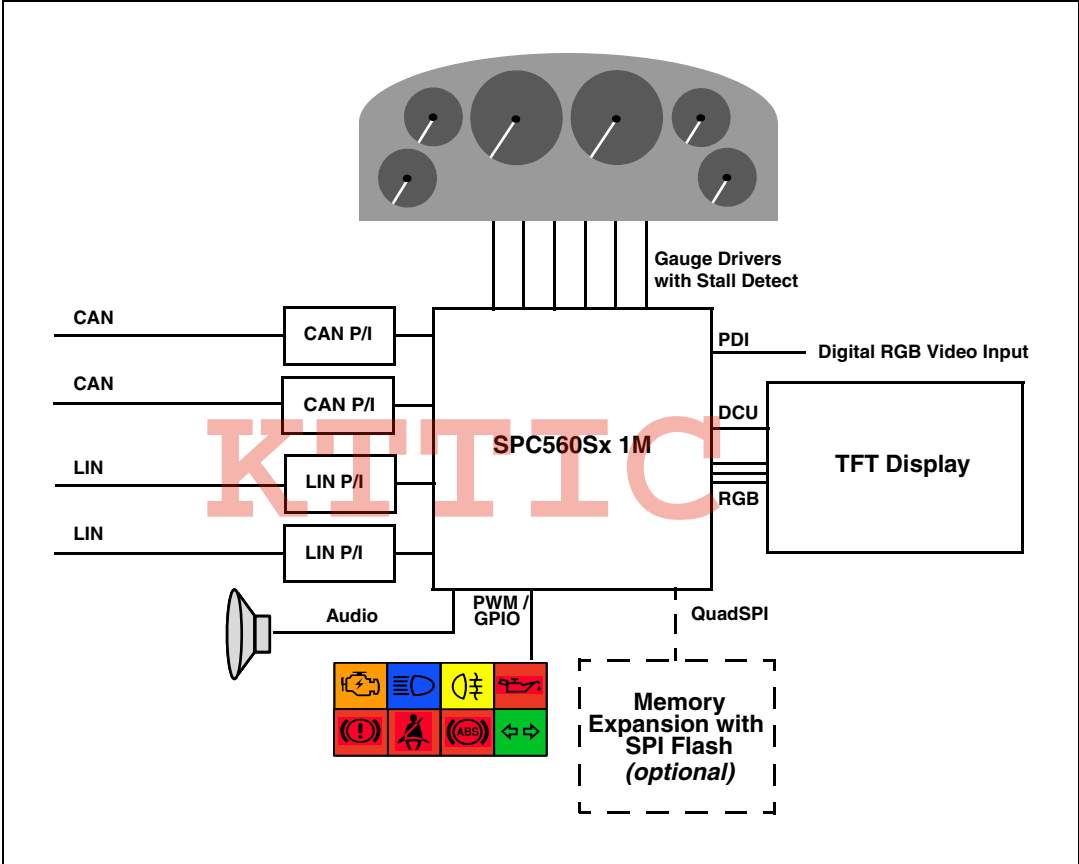

4.2 Instrument Cluster with LCD Segment Display

Figure 3 outlines an instrument cluster application supporting a monochrome dot matrix display built around the SPC560Sx microcontroller.

Figure 3. Instrument Cluster using SPC560Sx

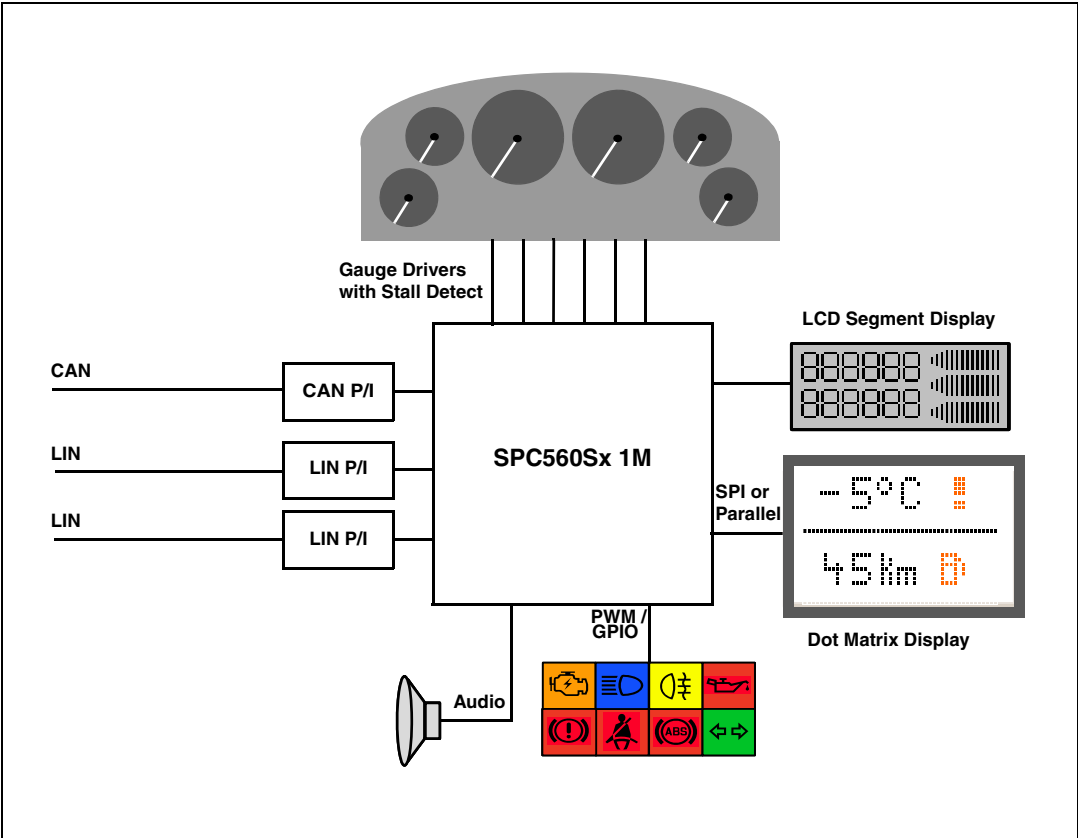

KTTIC

5 Developer Support

This family of MCUs is supported by a widespread, established network of tools and software vendors. It also features a high-performance Nexus debug interface.

The following development support will be available:

- Automotive Evaluation Boards (EVB) featuring CAN, LIN interfaces and more
- Compilers
- Debuggers
- JTAG and Nexus interfaces

The following software support will be available:

- OSEK solutions will be available from multiple third parties
- CAN and LIN drivers
- AUTOSAR package

KTTIC

6 Orderable Parts

Table 6. Orderable Part Number Summary

Part Number	Flash (Kbytes)	Package	Speed (MHz)
SPC560S50L7B6E0Y	512 KB	LQFP144	64
SPC560S60L5B6G0Y	1 MB	LQFP144	64
SPC560S60L7B6G0Y	1 MB	LQFP176	64

KTTIC

7 Document revision history

Table 7. Revision history

Date	Revision	Changes
13-Jun-2008	1	Initial release

KTTIC

Please Read Carefully:

Information in this document is provided solely in connection with ST products. STMicroelectronics NV and its subsidiaries ("ST") reserve the right to make changes, corrections, modifications or improvements, to this document, and the products and services described herein at any time, without notice.

All ST products are sold pursuant to ST's terms and conditions of sale.

Purchasers are solely responsible for the choice, selection and use of the ST products and services described herein, and ST assumes no liability whatsoever relating to the choice, selection or use of the ST products and services described herein.

No license, express or implied, by estoppel or otherwise, to any intellectual property rights is granted under this document. If any part of this document refers to any third party products or services it shall not be deemed a license grant by ST for the use of such third party products or services, or any intellectual property contained therein or considered as a warranty covering the use in any manner whatsoever of such third party products or services or any intellectual property contained therein.

UNLESS OTHERWISE SET FORTH IN ST'S TERMS AND CONDITIONS OF SALE ST DISCLAIMS ANY EXPRESS OR IMPLIED WARRANTY WITH RESPECT TO THE USE AND/OR SALE OF ST PRODUCTS INCLUDING WITHOUT LIMITATION IMPLIED WARRANTIES OF MERCHANTABILITY, FITNESS FOR A PARTICULAR PURPOSE (AND THEIR EQUIVALENTS UNDER THE LAWS OF ANY JURISDICTION), OR INFRINGEMENT OF ANY PATENT, COPYRIGHT OR OTHER INTELLECTUAL PROPERTY RIGHT.

UNLESS EXPRESSLY APPROVED IN WRITING BY AN AUTHORIZED ST REPRESENTATIVE, ST PRODUCTS ARE NOT RECOMMENDED, AUTHORIZED OR WARRANTED FOR USE IN MILITARY, AIR CRAFT, SPACE, LIFE SAVING, OR LIFE SUSTAINING APPLICATIONS, NOR IN PRODUCTS OR SYSTEMS WHERE FAILURE OR MALFUNCTION MAY RESULT IN PERSONAL INJURY, DEATH, OR SEVERE PROPERTY OR ENVIRONMENTAL DAMAGE. ST PRODUCTS WHICH ARE NOT SPECIFIED AS "AUTOMOTIVE GRADE" MAY ONLY BE USED IN AUTOMOTIVE APPLICATIONS AT USER'S OWN RISK.

Resale of ST products with provisions different from the statements and/or technical features set forth in this document shall immediately void any warranty granted by ST for the ST product or service described herein and shall not create or extend in any manner whatsoever, any liability of ST.

ST and the ST logo are trademarks or registered trademarks of ST in various countries.

Information in this document supersedes and replaces all information previously supplied.

The ST logo is a registered trademark of STMicroelectronics. All other names are the property of their respective owners.

© 2008 STMicroelectronics - All rights reserved

STMicroelectronics group of companies

Australia - Belgium - Brazil - Canada - China - Czech Republic - Finland - France - Germany - Hong Kong - India - Israel - Italy - Japan - Malaysia - Malta - Morocco - Singapore - Spain - Sweden - Switzerland - United Kingdom - United States of America

www.st.com

