



EMIF04-MMC02F2

4-line IPAD™, EMI filter including ESD protection

Features

- EMI symmetrical (I/O) low-pass filter
- High efficiency in EMI filtering
- Lead-free package
- Very low PCB space occupation: 1.57 mm x 2.07 mm
- Very thin package: 0.65 mm
- High efficiency in ESD suppression
- High reliability offered by monolithic integration
- High reduction of parasitic elements through integration and wafer level packaging

Complies with the standards:

- IEC 61000-4-2 Level 4
 - 15 kV (air discharge)
 - 8 kV (contact discharge)

Application

Where EMI filtering in ESD sensitive equipment is required:

- MultiMediaCard for mobile phones, personal digital assistant, digital camera, MP3 players...

Description

The EMIF04-MMC02 is a highly integrated device designed to suppress EMI/RFI noise for a MultiMediaCard port. The EMIF04 Flip Chip packaging means the package size is equal to the die size.

This filter includes ESD protection circuitry, which prevents damage to the application when it is subjected to ESD surges up to 15 kV.

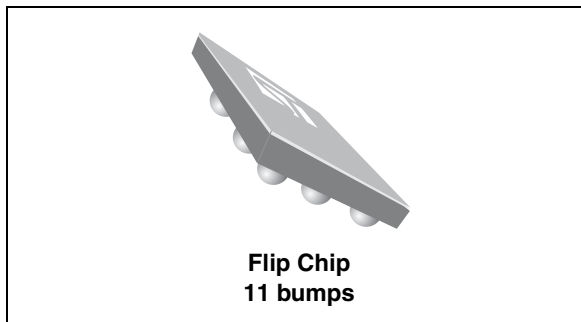

Figure 1. Pin layout (bump side)

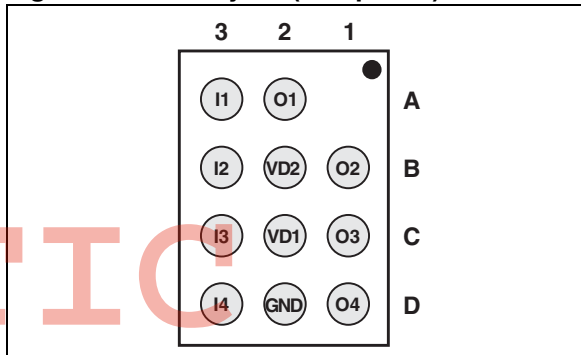
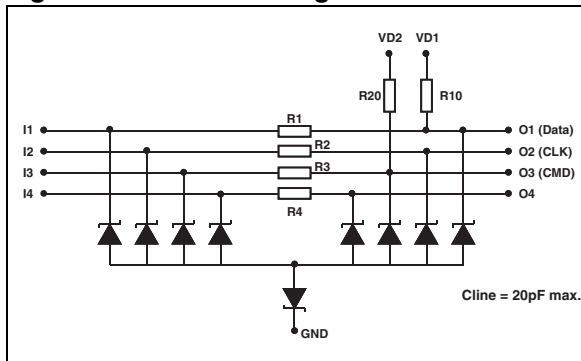

Figure 2. Device configuration



TM: IPAD is a trademark of STMicroelectronics.

1 Electrical characteristics

Table 1. Absolute maximum ratings ($T_{amb} = 25\text{ }^{\circ}\text{C}$)

Symbol	Parameter	Value	Unit
P_R	DC power per resistor	70	mW
T_j	Junction temperature	125	$^{\circ}\text{C}$
T_{op}	Operating temperature range	-40 to + 85	$^{\circ}\text{C}$
T_{stg}	Storage temperature range	-55 to +150	$^{\circ}\text{C}$

Table 2. Electrical characteristics ($T_{amb} = 25\text{ }^{\circ}\text{C}$)

Symbol	Parameters				
V_{BR}	Breakdown voltage				
I_{RM}	Leakage current @ V_{RM}				
V_{RM}	Stand-off voltage				
V_{CL}	Clamping voltage				
R_d	Dynamic impedance				
I_{PP}	Peak pulse current				
$R_{I/O}$	Series resistance between input and output				
C_{line}	Input capacitance per line				
Symbol	Test conditions				
V_{BR}	$I_R = 1\text{ mA}$	6			V
I_{RM}	$V_{RM} = 3\text{ V}$		0.1	0.5	μA
C_{line}	@ 0 V			20	pF
R_1, R_2, R_3, R_4	Tolerance $\pm 5\%$		47		Ω
R_{10}	Tolerance $\pm 5\%$		13		k Ω
R_{20}	Tolerance $\pm 5\%$		56		k Ω

Figure 3. S21 (dB) attenuation measurement and Aplac simulation

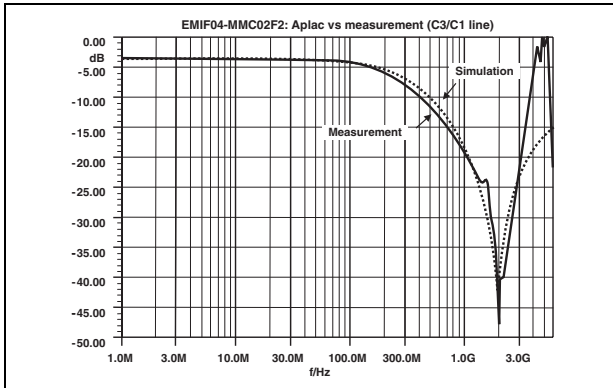

Figure 4. Cross talk measurement

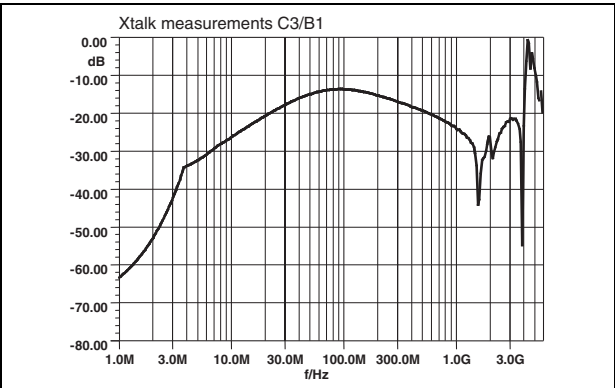

Figure 5. ESD response to IEC 61000-4-2 (+15kV contact discharge) on one input (Vin) and one output (Vout)

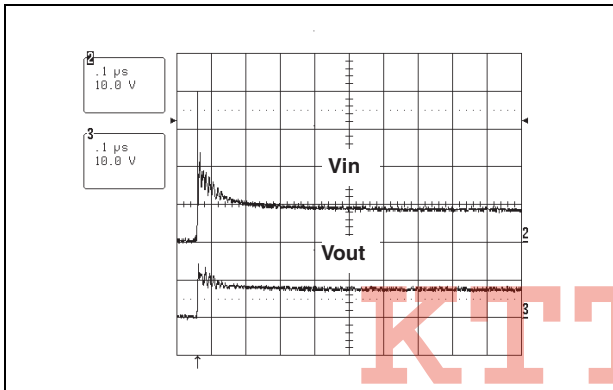

Figure 6. ESD response to IEC 61000-4-2 (-15kV contact discharge) on one input (Vin) and one output (Vout)

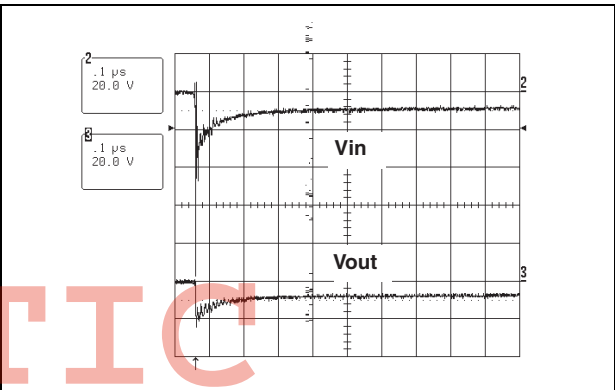
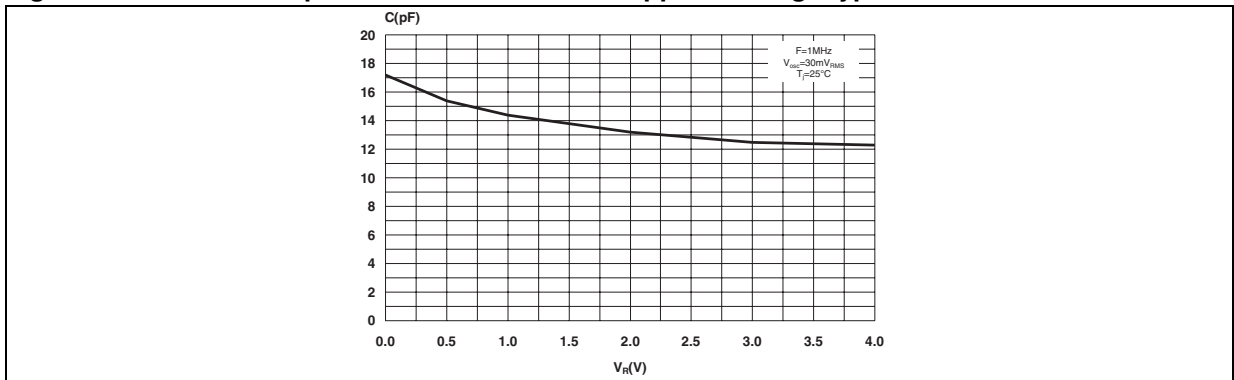

Figure 7. Junction capacitance versus reverse applied voltage typical values



2 Application information

Figure 8. Device structure

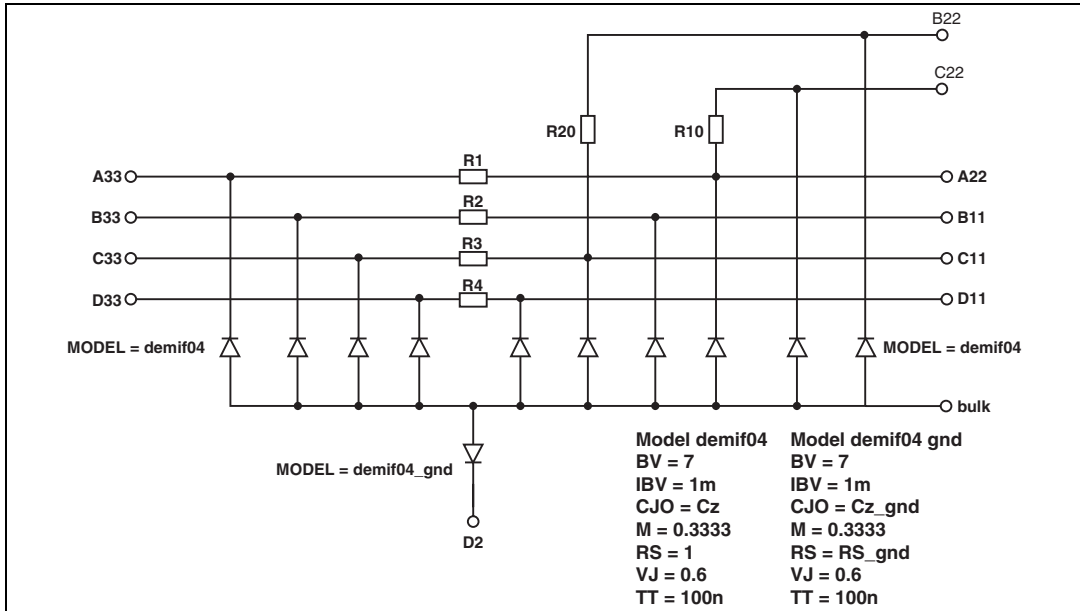
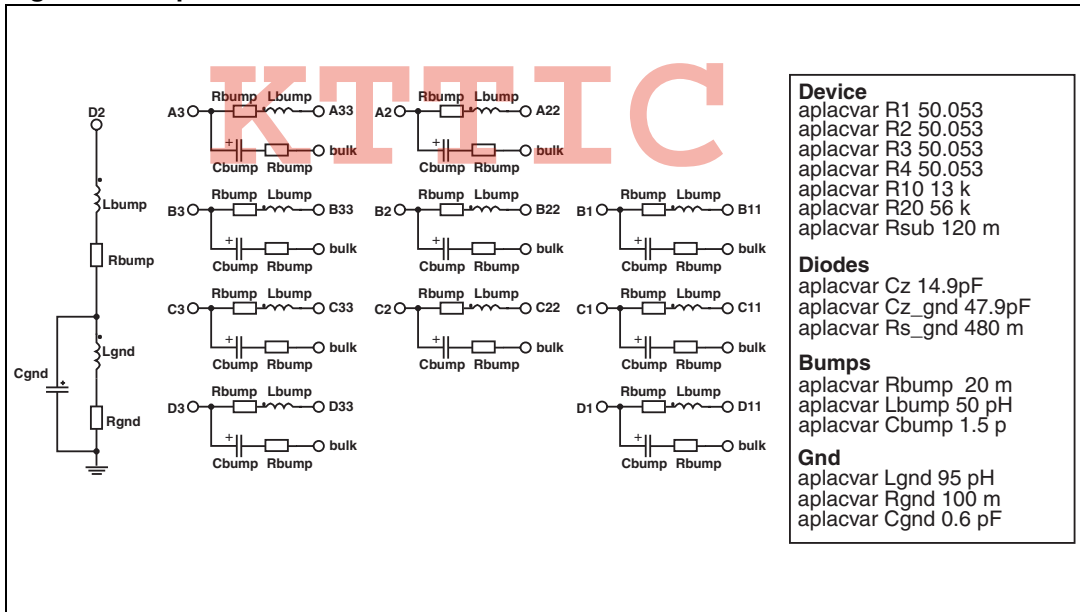
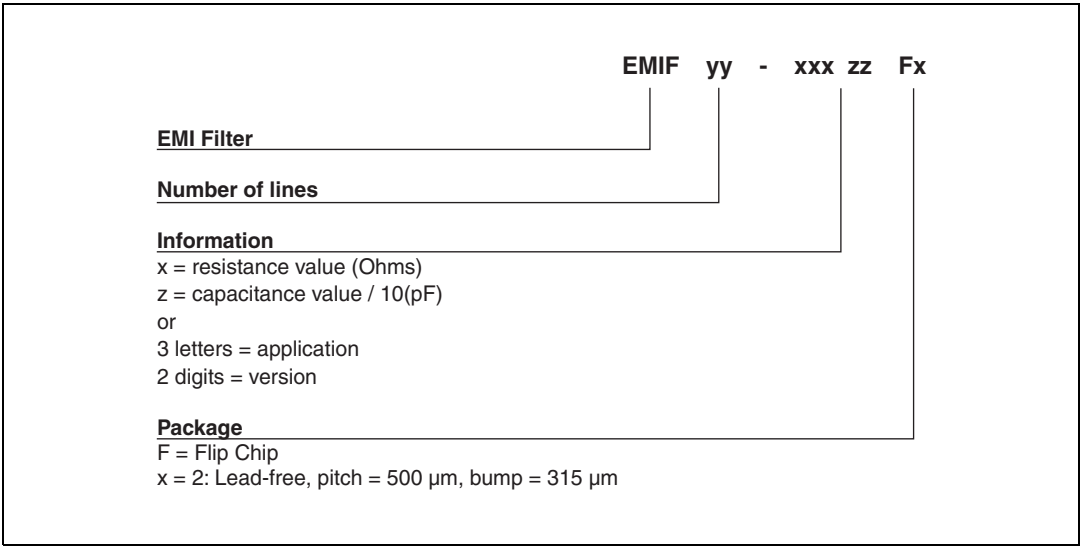

Figure 9. Aplac model connections



3 Ordering information scheme

Figure 10. Ordering information scheme



4 Package information

In order to meet environmental requirements, ST offers these devices in ECOPACK® packages. These packages have a lead-free second level interconnect. The category of second level interconnect is marked on the inner box label, in compliance with JEDEC Standard JESD97. The maximum ratings related to soldering conditions are also marked on the inner box label. ECOPACK is an ST trademark. ECOPACK specifications are available at www.st.com.

Figure 11. Flip Chip dimensions

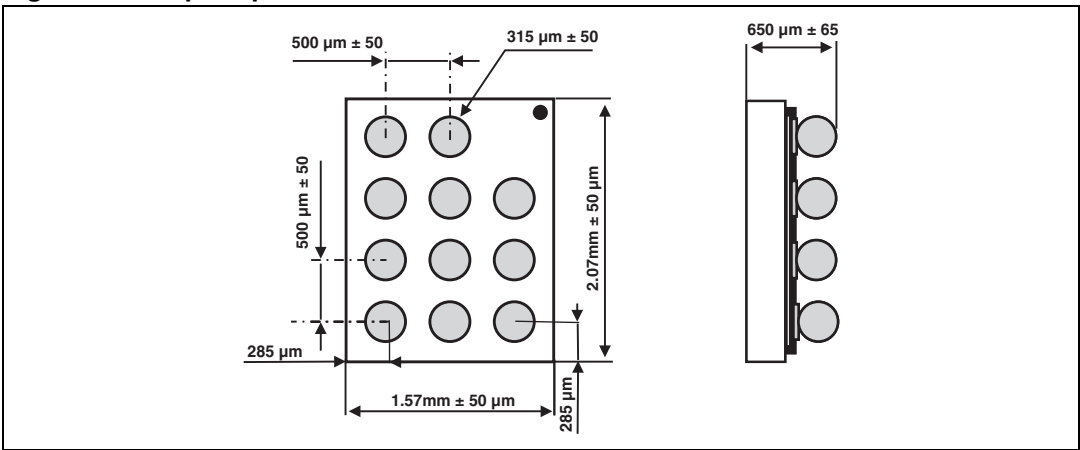

Figure 12. Footprint

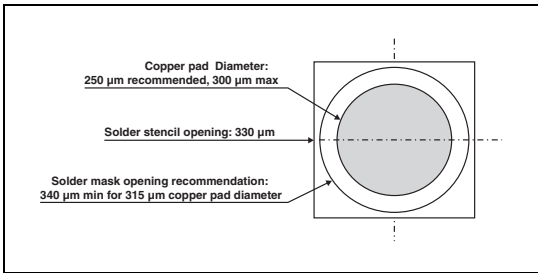

Figure 13. Marking

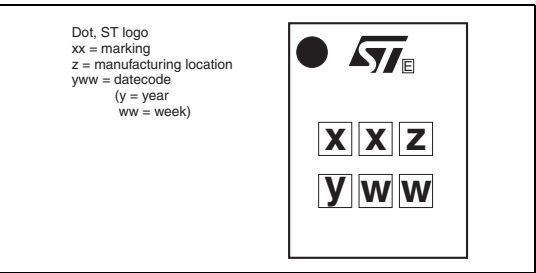
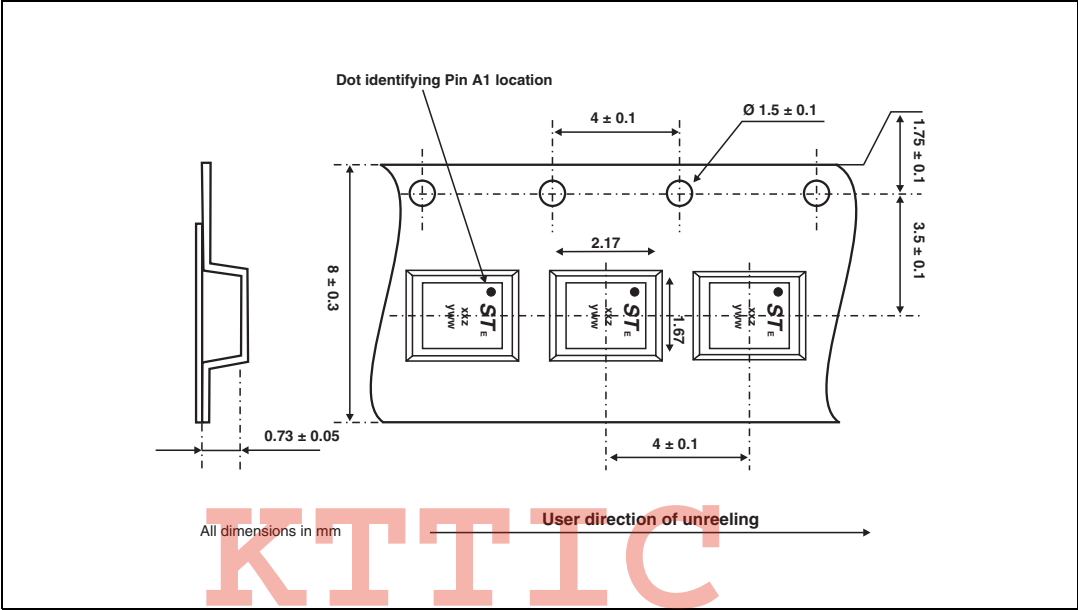

Figure 14. Flip Chip tape and reel specification



5 Ordering information

Table 3. Ordering information

Order code	Marking	Package	Weight	Base qty	Delivery mode
EMIF04-MMC02F2	FH	Flip Chip	4.5 mg	5000	Tape and reel (7")

Note: More packing information is available in the applications note:
AN1235: "Flip Chip: package description and recommendations for use"
AN 1751: "EMI filters: Recommendations and measurements"

6 Revision history

Table 4. Document revision history

Date	Revision	Changes
14-Oct-2004	1	First issue
06-Apr-2005	2	Minor layout update. No content change.
25-Aug-2005	3	Reformatted to current standard, Aplac model updated in section 2.
28-Apr-2008	4	Updated ECOPACK statement. Updated Figure 10 , Figure 11 and Figure 14 . Reformatted to current standards.

KTTIC

Please Read Carefully:

Information in this document is provided solely in connection with ST products. STMicroelectronics NV and its subsidiaries ("ST") reserve the right to make changes, corrections, modifications or improvements, to this document, and the products and services described herein at any time, without notice.

All ST products are sold pursuant to ST's terms and conditions of sale.

Purchasers are solely responsible for the choice, selection and use of the ST products and services described herein, and ST assumes no liability whatsoever relating to the choice, selection or use of the ST products and services described herein.

No license, express or implied, by estoppel or otherwise, to any intellectual property rights is granted under this document. If any part of this document refers to any third party products or services it shall not be deemed a license grant by ST for the use of such third party products or services, or any intellectual property contained therein or considered as a warranty covering the use in any manner whatsoever of such third party products or services or any intellectual property contained therein.

UNLESS OTHERWISE SET FORTH IN ST'S TERMS AND CONDITIONS OF SALE ST DISCLAIMS ANY EXPRESS OR IMPLIED WARRANTY WITH RESPECT TO THE USE AND/OR SALE OF ST PRODUCTS INCLUDING WITHOUT LIMITATION IMPLIED WARRANTIES OF MERCHANTABILITY, FITNESS FOR A PARTICULAR PURPOSE (AND THEIR EQUIVALENTS UNDER THE LAWS OF ANY JURISDICTION), OR INFRINGEMENT OF ANY PATENT, COPYRIGHT OR OTHER INTELLECTUAL PROPERTY RIGHT.

UNLESS EXPRESSLY APPROVED IN WRITING BY AN AUTHORIZED ST REPRESENTATIVE, ST PRODUCTS ARE NOT RECOMMENDED, AUTHORIZED OR WARRANTED FOR USE IN MILITARY, AIR CRAFT, SPACE, LIFE SAVING, OR LIFE SUSTAINING APPLICATIONS, NOR IN PRODUCTS OR SYSTEMS WHERE FAILURE OR MALFUNCTION MAY RESULT IN PERSONAL INJURY, DEATH, OR SEVERE PROPERTY OR ENVIRONMENTAL DAMAGE. ST PRODUCTS WHICH ARE NOT SPECIFIED AS "AUTOMOTIVE GRADE" MAY ONLY BE USED IN AUTOMOTIVE APPLICATIONS AT USER'S OWN RISK.

Resale of ST products with provisions different from the statements and/or technical features set forth in this document shall immediately void any warranty granted by ST for the ST product or service described herein and shall not create or extend in any manner whatsoever, any liability of ST.

ST and the ST logo are trademarks or registered trademarks of ST in various countries.

Information in this document supersedes and replaces all information previously supplied.

The ST logo is a registered trademark of STMicroelectronics. All other names are the property of their respective owners.

© 2008 STMicroelectronics - All rights reserved

STMicroelectronics group of companies

Australia - Belgium - Brazil - Canada - China - Czech Republic - Finland - France - Germany - Hong Kong - India - Israel - Italy - Japan - Malaysia - Malta - Morocco - Singapore - Spain - Sweden - Switzerland - United Kingdom - United States of America

www.st.com