

ZT SERIES

Load Life: 125°C 1000~4000hours. Low impedance.

◆ **FEATURES**

- Low impedance at 100kHz with selected materials.
- Load Life : 125°C 1000~4000hours.
- RoHS compliance.

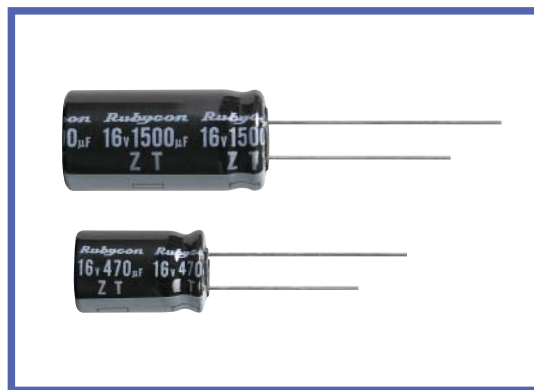

◆ **SPECIFICATIONS**

Items	Characteristics																		
Category Temperature Range	-40 ~ +125°C																		
Rated Voltage Range	10~35V.DC																		
Capacitance Tolerance	± 20%(20°C, 120Hz)																		
Leakage Current(MAX)	I=0.03CV or 3µA whichever is greater. (After 2 minutes) I=Leakage Current(µA) C=Rated Capacitance(µF) V=Rated Voltage(V)																		
Dissipation Factor(MAX) (tanδ)	<table border="1"> <tr> <td>Rated Voltage (V)</td> <td>10</td> <td>16</td> <td>25</td> <td>35</td> <td>(20°C, 120Hz)</td> </tr> <tr> <td>tanδ</td> <td>0.20</td> <td>0.16</td> <td>0.14</td> <td>0.12</td> <td></td> </tr> </table> <p>When nominal capacitance is over 1000µF, tanδ shall be added 0.02 to the listed value with increase of every 1000µF.</p>	Rated Voltage (V)	10	16	25	35	(20°C, 120Hz)	tanδ	0.20	0.16	0.14	0.12							
Rated Voltage (V)	10	16	25	35	(20°C, 120Hz)														
tanδ	0.20	0.16	0.14	0.12															
Endurance	<p>After life test with rated ripple current at conditions stated in the table below, the capacitors shall meet the following requirements.</p> <table border="1"> <tr> <td>Capacitance Change</td> <td>Within ± 30% of the initial value.</td> <td rowspan="3"> <table border="1"> <tr> <th>Case Size</th> <th>Life Time (hrs)</th> </tr> <tr> <td>φD ≤ 6.3</td> <td>1000</td> </tr> <tr> <td>φD = 8</td> <td>2000</td> </tr> <tr> <td>φD = 10</td> <td>3000</td> </tr> <tr> <td>φD = 12.5</td> <td>4000</td> </tr> </table> </td> </tr> <tr> <td>Dissipation Factor</td> <td>Not more than 300% of the specified value.</td> </tr> <tr> <td>Leakage Current</td> <td>Not more than the specified value.</td> </tr> </table>	Capacitance Change	Within ± 30% of the initial value.	<table border="1"> <tr> <th>Case Size</th> <th>Life Time (hrs)</th> </tr> <tr> <td>φD ≤ 6.3</td> <td>1000</td> </tr> <tr> <td>φD = 8</td> <td>2000</td> </tr> <tr> <td>φD = 10</td> <td>3000</td> </tr> <tr> <td>φD = 12.5</td> <td>4000</td> </tr> </table>	Case Size	Life Time (hrs)	φD ≤ 6.3	1000	φD = 8	2000	φD = 10	3000	φD = 12.5	4000	Dissipation Factor	Not more than 300% of the specified value.	Leakage Current	Not more than the specified value.	
Capacitance Change	Within ± 30% of the initial value.	<table border="1"> <tr> <th>Case Size</th> <th>Life Time (hrs)</th> </tr> <tr> <td>φD ≤ 6.3</td> <td>1000</td> </tr> <tr> <td>φD = 8</td> <td>2000</td> </tr> <tr> <td>φD = 10</td> <td>3000</td> </tr> <tr> <td>φD = 12.5</td> <td>4000</td> </tr> </table>	Case Size		Life Time (hrs)	φD ≤ 6.3	1000	φD = 8	2000	φD = 10	3000	φD = 12.5	4000						
Case Size	Life Time (hrs)																		
φD ≤ 6.3	1000																		
φD = 8	2000																		
φD = 10	3000																		
φD = 12.5	4000																		
Dissipation Factor	Not more than 300% of the specified value.																		
Leakage Current	Not more than the specified value.																		
Low Temperature Stability	<table border="1"> <tr> <td>Rated Voltage (V)</td> <td>10</td> <td>16</td> <td>25</td> <td>35</td> <td>(120Hz)</td> </tr> <tr> <td>Z(-25°C)/Z(20°C)</td> <td>3</td> <td>2</td> <td>2</td> <td>2</td> <td></td> </tr> <tr> <td>Z(-40°C)/Z(20°C)</td> <td>6</td> <td>4</td> <td>3</td> <td>3</td> <td></td> </tr> </table>	Rated Voltage (V)	10	16	25	35	(120Hz)	Z(-25°C)/Z(20°C)	3	2	2	2		Z(-40°C)/Z(20°C)	6	4	3	3	
Rated Voltage (V)	10	16	25	35	(120Hz)														
Z(-25°C)/Z(20°C)	3	2	2	2															
Z(-40°C)/Z(20°C)	6	4	3	3															
Impedance Ratio(MAX)																			

◆ **MULTIPLIER FOR RIPPLE CURRENT**

Frequency coefficient

Frequency (Hz)		120	1k	10k	100k ≤
Coefficient	22~33µF	0.20	0.50	0.80	1.00
	39~100µF	0.25	0.60	0.90	1.00
	120~270µF	0.35	0.70	0.92	1.00
	330~680µF	0.45	0.75	0.95	1.00
	820~1800µF	0.50	0.80	0.96	1.00
	2200µF	0.55	0.85	0.98	1.00

◆ **DIMENSIONS**

(mm)

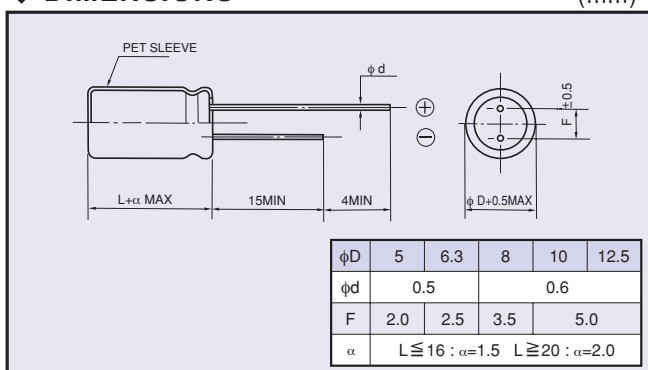

◆ **PART NUMBER**

 ZT D x L
 Rated Voltage Series Rated Capacitance Capacitance Tolerance Option Lead Forming Case Size



◆ STANDARD SIZE

Rated Voltage (V·DC)	Rated capacitance (μF)	Size φ DxL(mm)	Rated ripple current (mA r.m.s./125°C,100kHz)	(Ω MAX) Impedance		
				20°C, 100kHz	-10°C, 100kHz	
10 (1A)	56	5x11	250	0.40	1.3	
	120	6.3x11	405	0.17	0.53	
	330	8x11.5	760	0.094	0.29	
	470	8x16	995	0.073	0.23	
	680	8x20	1250	0.054	0.17	
	470	10x12.5	1030	0.069	0.21	
	680	10x16	1430	0.050	0.16	
	1000	10x20	1500	0.030	0.090	
	1200	10x23	1620	0.029	0.086	
	1500	12.5x20	1720	0.028	0.069	
	2200	12.5x25	1900	0.024	0.059	
16 (1C)	47	5x11	250	0.40	1.3	
	100	6.3x11	405	0.17	0.53	
	220	8x11.5	760	0.094	0.29	
	330	8x16	995	0.073	0.23	
	470	8x20	1250	0.054	0.17	
	330	10x12.5	1030	0.069	0.21	
	470	10x16	1430	0.050	0.16	
	680	10x20	1500	0.030	0.090	
	820	10x23	1620	0.029	0.086	
	1000	12.5x20	1720	0.028	0.069	
	1500	12.5x25	1900	0.024	0.059	
25 (1E)	33	5x11	250	0.40	1.3	
	56	6.3x11	405	0.17	0.53	
	150	8x11.5	760	0.094	0.29	
	220	8x16	995	0.073	0.23	
	270	8x20	1250	0.054	0.17	
	220	10x12.5	1030	0.069	0.21	
	330	10x16	1430	0.050	0.16	
	470	10x20	1500	0.030	0.090	
	560	10x23	1620	0.029	0.086	
	680	12.5x20	1720	0.028	0.069	
	1000	12.5x25	1900	0.024	0.059	
	35 (1V)	22	5x11	250	0.40	1.3
		56	6.3x11	405	0.17	0.53
100		8x11.5	760	0.094	0.29	
120		8x16	995	0.073	0.23	
180		8x20	1250	0.054	0.17	
150		10x12.5	1030	0.069	0.21	
220		10x16	1430	0.050	0.16	
270		10x20	1500	0.030	0.090	
330		10x23	1620	0.029	0.086	
470		12.5x20	1720	0.028	0.069	
560		12.5x25	1900	0.024	0.059	