



**TWL SERIES**

**Low Leakage Current**

◆ **FEATURES**

- RoHS compliance.

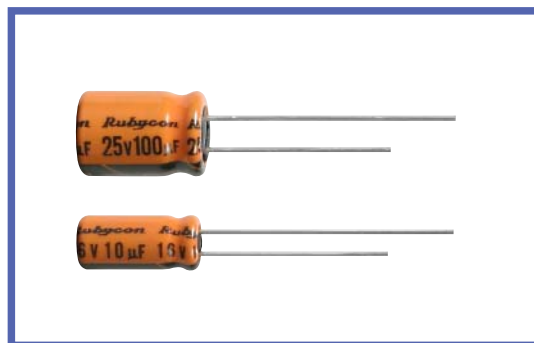

◆ **SPECIFICATIONS**

Items	Characteristics																																
Category Temperature Range	-40 ~ +85°C																																
Rated Voltage Range	6.3~50V.DC																																
Capacitance Tolerance	± 20%(20°C,120Hz)																																
Leakage Current(MAX)	I=0.002CV or 0.4=A whichever is greater. (After 2 minutes application of rated voltage) I=Leakage Current(=A)    C=Rated Capacitance(µF)    V=Rated Voltage(V)																																
Dissipation Factor(MAX) (tanδ)	<p>&lt;L=7&gt;</p> <table border="1"> <tr> <td>Rated Voltage (V)</td> <td>6.3</td> <td>10</td> <td>16</td> <td>25</td> <td>35</td> <td>50</td> <td>(20°C,120Hz)</td> </tr> <tr> <td>tanδ</td> <td>0.24</td> <td>0.20</td> <td>0.16</td> <td>0.14</td> <td>0.12</td> <td>0.10</td> <td></td> </tr> </table> <p>&lt;L≥11&gt;</p> <table border="1"> <tr> <td>Rated Voltage (V)</td> <td>6.3</td> <td>10</td> <td>16</td> <td>25</td> <td>35</td> <td>50</td> <td>(20°C,120Hz)</td> </tr> <tr> <td>tanδ</td> <td>0.22</td> <td>0.19</td> <td>0.16</td> <td>0.14</td> <td>0.12</td> <td>0.10</td> <td></td> </tr> </table> <p>When rated capacitance is over 1000µF, tanδ shall be added 0.02 to the listed value with increase of every 1000µF.</p>	Rated Voltage (V)	6.3	10	16	25	35	50	(20°C,120Hz)	tanδ	0.24	0.20	0.16	0.14	0.12	0.10		Rated Voltage (V)	6.3	10	16	25	35	50	(20°C,120Hz)	tanδ	0.22	0.19	0.16	0.14	0.12	0.10	
Rated Voltage (V)	6.3	10	16	25	35	50	(20°C,120Hz)																										
tanδ	0.24	0.20	0.16	0.14	0.12	0.10																											
Rated Voltage (V)	6.3	10	16	25	35	50	(20°C,120Hz)																										
tanδ	0.22	0.19	0.16	0.14	0.12	0.10																											
Endurance	<p>After life test with rated ripple current at conditions stated in the table below, the capacitors shall meet the following requirements.</p> <table border="1"> <tr> <td>Capacitance Change</td> <td>Within ±25% of the initial value.</td> <td>Case Size</td> <td>Life Time (hrs)</td> </tr> <tr> <td>Dissipation Factor</td> <td>Not more than 200% of the specified value.</td> <td>L=7</td> <td>1000</td> </tr> <tr> <td>Leakage Current</td> <td>Not more than the specified value.</td> <td>L≥11</td> <td>2000</td> </tr> </table>	Capacitance Change	Within ±25% of the initial value.	Case Size	Life Time (hrs)	Dissipation Factor	Not more than 200% of the specified value.	L=7	1000	Leakage Current	Not more than the specified value.	L≥11	2000																				
Capacitance Change	Within ±25% of the initial value.	Case Size	Life Time (hrs)																														
Dissipation Factor	Not more than 200% of the specified value.	L=7	1000																														
Leakage Current	Not more than the specified value.	L≥11	2000																														
Low Temperature Stability Impedance Ratio(MAX)	<table border="1"> <tr> <td>Rated Voltage (V)</td> <td>6.3</td> <td>10</td> <td>16</td> <td>25</td> <td>35</td> <td>50</td> <td>(120Hz)</td> </tr> <tr> <td>Z(-25°C)/Z(20°C)</td> <td>4</td> <td>3</td> <td>2</td> <td>2</td> <td>2</td> <td>2</td> <td></td> </tr> <tr> <td>Z(-40°C)/Z(20°C)</td> <td>8</td> <td>6</td> <td>6</td> <td>4</td> <td>4</td> <td>3</td> <td></td> </tr> </table>	Rated Voltage (V)	6.3	10	16	25	35	50	(120Hz)	Z(-25°C)/Z(20°C)	4	3	2	2	2	2		Z(-40°C)/Z(20°C)	8	6	6	4	4	3									
Rated Voltage (V)	6.3	10	16	25	35	50	(120Hz)																										
Z(-25°C)/Z(20°C)	4	3	2	2	2	2																											
Z(-40°C)/Z(20°C)	8	6	6	4	4	3																											

◆ **MULTIPLIER FOR RIPPLE CURRENT**

Frequency coefficient

Frequency (Hz)		60(50)	120	500	1k	10k≤
Coefficient	0.1~1µF	0.50	1.00	1.20	1.30	1.50
	2.2~4.7µF	0.65	1.00	1.20	1.30	1.50
	10~47µF	0.80	1.00	1.20	1.30	1.50
	100~1000µF	0.80	1.00	1.10	1.15	1.20
	2200µF	0.80	1.00	1.05	1.10	1.15

◆ **PART NUMBER**

□□□ TWL □□□□□ □ □□□ □□ D×L  
 Rated Voltage    Series    Rated Capacitance    Capacitance Tolerance    Option    Lead Forming    Case Size



◆ DIMENSIONS

(mm)

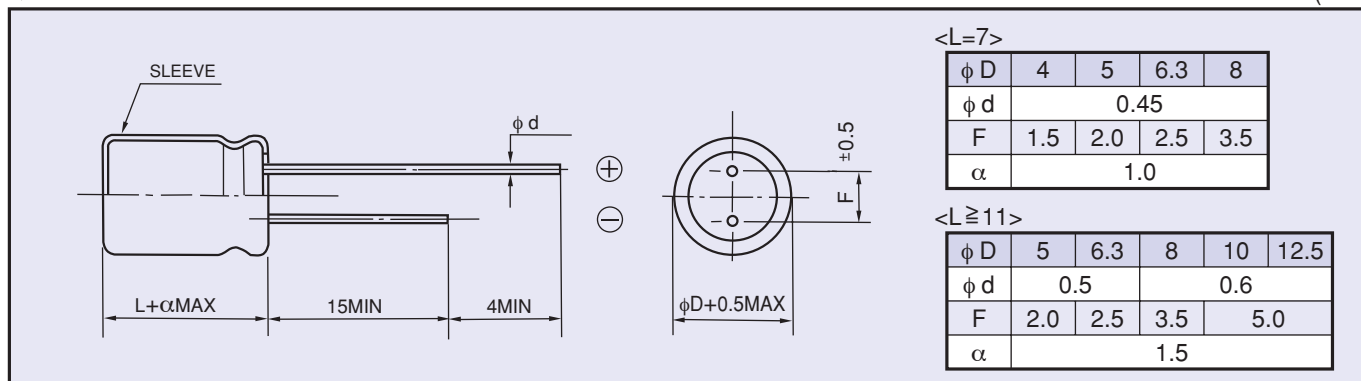

◆ STANDARD SIZE

Size  $\phi D \times L$ (mm), Ripple Current (mA r.m.s./85°C, 120Hz)

Cap( $\mu F$ )	6.3 (0J)		10 (1A)		16 (1C)		25 (1E)		35 (1V)		50 (1H)	
	Size	Ripple	Size	Ripple	Size	Ripple	Size	Ripple	Size	Ripple	Size	Ripple
0.1											4x7	1.0
											5x11	1.1
0.22											4x7	2.3
											5x11	2.5
0.33											4x7	3.5
											5x11	4.0
0.47											4x7	5.0
											5x11	7.0
1											4x7	10
											5x11	13
2.2											4x7	16
											5x11	23
3.3											4x7	19
											5x11	35
4.7							4x7	21	4x7	22	5x7	29
							5x11	30	5x11	35	5x11	41
10					4x7	28	5x7	33	5x7	32	6.3x7	44
					5x11	40	5x11	50	5x11	55	5x11	60
22	4x7	34	5x7	38	5x7	44	6.3x7	55	6.3x7	60	8x7	65
	5x11	48	5x11	55	5x11	70	5x11	87	5x11	95	6.3x11	110
33	5x7	42	5x7	47	6.3x7	62	6.3x7	65	8x7	73	6.3x11	140
	5x11	55	5x11	74	5x11	90	5x11	110	6.3x11	120		
47	5x7	50	6.3x7	66	6.3x7	73	8x7	80			8x11.5	190
	5x11	79	5x11	90	5x11	120	6.3x11	130	6.3x11	145		
100	6.3x7	87	8x7	99	8x7	110					10x12.5	300
	5x11	100	6.3x11	150	6.3x11	185	8x11.5	210	8x11.5	250		
220	8x7	133	8x11.5	280	8x11.5	310	10x12.5	370	10x16	420	10x20	490
	6.3x11	220										
330	8x11.5	310	8x11.5	360	10x12.5	410	10x16	480	10x20	540	12.5x20	680
470	8x11.5	400	10x12.5	460	10x16	530	10x20	600	12.5x20	730		
1000	10x16	660	10x20	760	12.5x20	900	12.5x25	1000				
2200	12.5x20	1050	12.5x25	1200								