

TYPE
NAME

PD7088,PD708C8

DESCRIPTION

PD7XX8 series are InGaAs pin photodiode which has a sensitive area of $\phi 80\mu\text{m}$.

PD7XX8 is suitable for receiving the light having a wavelength band of 1000 to 1600nm. This photodiode features high-speed response and a high quantum efficiency, and is suitable for the light receiving elements for optical fiber communication systems.

FEATURES

- $\phi 80\mu\text{m}$ active diameter
- 1000 ~1600nm wavelength band
- Small dark current
- High speed response
- High quantum efficiency
- Ball lens cap (PD708C8)

APPLICATION

Receiver for long-distance optical fiber communication systems

KTTIC

ABSOLUTE MAXIMUM RATING





Symbol	Parameter	Conditions	Ratings	Unit
V_R	Reverse voltage	-	20	V
I_R	Reverse current	-	500	μA
I_F	Forward current	-	2	mA
T_C	Case temperature	-	-40 ~ +85	$^{\circ}\text{C}$
T_{stg}	Storage temperature	-	-40 ~ +100	$^{\circ}\text{C}$

ELECTRICAL/OPTICAL CHARACTERISTICS ($T_C = 25^{\circ}\text{C}$)

Symbol	Parameter	Test conditions	Limits			Unit
			Min.	Typ.	Max.	
C_t	Capacitance	$V_R = 5\text{V}, f = 1\text{MHz}$	-	1.2	2	pF
I_D	Dark current	$V_R = 5\text{V}$	-	0.05	2.0	nA
R	Responsivity	$V_R = 5\text{V}, \lambda = 1300\text{nm}$	0.6	0.9*	-	A/W
f_c	Cutoff frequency	$V_R = 5\text{V}, \lambda = 1300\text{nm}, R_L = 50\Omega, -3\text{dB}$	1	2.0	-	GHz

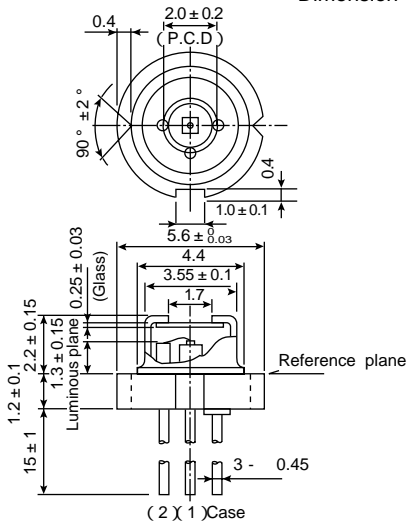
* 0.85A/W typical fiber coupling sensitivity with GI 50/125 for PD708C8

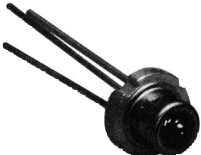
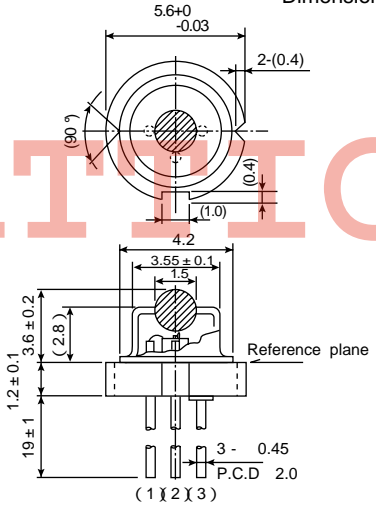
OUTLINE DRAWINGS

<p>PD7088</p> 	<p>Dimension : mm</p> 	
<p>PD708C8</p> 	<p>Dimension : mm</p> 	

TYPICAL CHARACTERISTICS

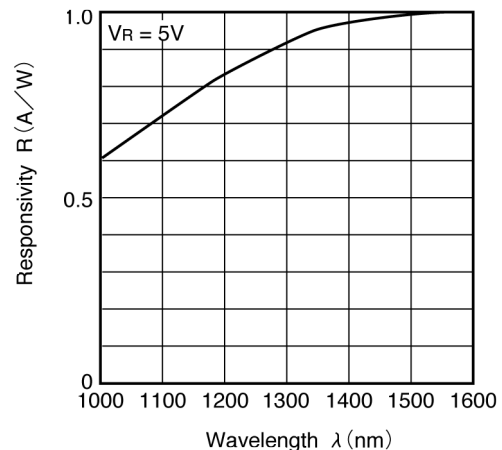

Fig.1 Spectral response

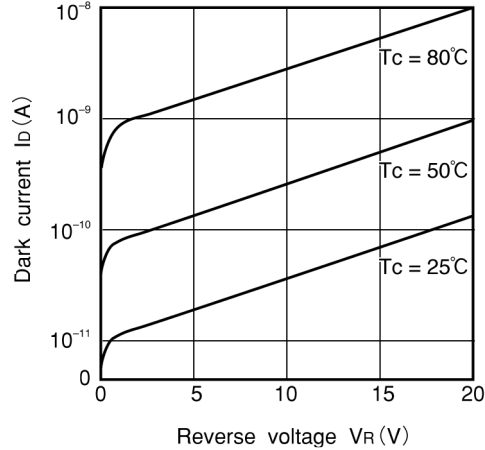

Fig.2 Dark current vs. reverse voltage

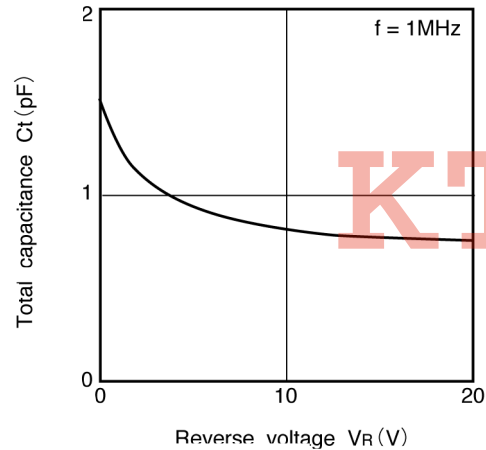

Fig.3 Total capacitance vs. reverse voltage

KTTIC