

Notice : Some parametric limits are subject to change

TYPE NAME	ML725B11F/ML720J11S
	ML725AA11F / ML720AA11S
	ML725J11F / ML720L11S

DESCRIPTION

ML7XX11series are DFB (Distributed Feedback) laser diodes emitting light beam around 1310nm. They are well suited for light source in long distance digital transmission system. They are hermetically sealed devices with the photo diode for optical output monitoring.

APPLICATION

· ~1.25Gbps digital transmission system

FEATURES

- Homogeneous grating (AR/HR facet coating) structure DFB
- Wide temperature range operation (-40 to 85°C)
- Low threshold current (typical 6mA)
- High speed response (typical 0.1nsec)
- φ5.6mm TO-CAN package
- Flat window cap, Ball lens cap, or Aspherical lens cap

ABSOLUTE MAXIMUM RATINGS

Symbol	Parameter	Conditions	Ratings	Unit
Po	Light output power	CW	10	mW
If	Forward current (Laser diode)	---	150	mA
V _{RL}	Reverse voltage (Laser diode)	---	2	V
V _{RD}	Reverse voltage (Photo diode)	---	20	V
I _{FD}	Forward current (Photo diode)	---	2	mA
Tc	Case temperature	---	-40 to +85	°C
Tstg	Storage temperature	---	-40 to +100	°C

ELECTRICAL/OPTICAL CHARACTERISTICS (Tc=25°C otherwise specified)

[Flat window cap : ML725B11F / ML720J11S]

Symbol	Parameter	Test conditions	Min.	Typ.	Max.	Unit
I _{th}	Threshold current	CW	---	6	12	mA
		CW, Tc=85°C	---	30	40	
I _{op}	Operation current	CW, Po=5mW	---	16	30	mA
		CW, Po=5mW, Tc=85°C	---	50	75	
V _{op}	Operating voltage	CW, Po=5mW	---	1.1	1.5	V
η	Slope efficiency	CW, Po=5mW	0.3	0.5	---	mW/mA
λ _p	Peak wavelength	CW, Po=5mW	1290	1310	1330	nm
θ _{//}	Beam divergence angle (parallel)	CW, Po=5mW	---	25	35	deg.
θ _⊥	Beam divergence angle (perpendicular)	CW, Po=5mW	---	30	40	deg.
SMSR	Side mode suppression ratio	CW, Po=5mW Tc= - 40 to +85°C	35	40	---	dB
t _{r,tf}	Rise and Fall time	I _b =I _{th} , 20-80% <*>	---	0.1	0.2	ns
I _m	Monitoring output current (PD)	CW, Po=5mW	0.05	0.2	---	mA
I _d	Dark current (PD)	V _{RD} =5V	---	---	0.1	μA
C _t	Capacitance (PD)	V _{RD} =5V	---	10	20	pF

<*> Except influence of the 18mm lead.

Notice : Some parametric limits are subject to change

ELECTRICAL/OPTICAL CHARACTERISTICS (Tc=25°C otherwise specified)

[Ball lens cap ; ML725AA11F / ML720AA11S]

Symbol	Parameter	Test conditions	Min.	Typ.	Max.	Unit
Ith	Threshold current	CW	---	6	12	mA
		CW, Tc=85°C	---	30	40	
Iop	Operation current	CW, Po=5mW	---	16	30	mA
		CW, Po=5mW, Tc=85°C	---	50	75	
Vop	Operating voltage	CW, Po=5mW	---	1.1	1.5	V
η	Slope efficiency	CW, Po=5mW	0.3	0.5	---	mW/mA
λp	Peak wavelength	CW, Po=5mW	1290	1310	1330	nm
SMSR	Side mode suppression ratio	CW, Po=5mW Tc= - 40 to +85°C	35	40	---	dB
Pf	Fiber coupling power	CW, Po=5mW, SMF	0.5	1.0	---	mW
Df	Focul length	CW, Po=5mW, SMF	6.0	6.5	7.0	mm
tr,tf	Rise and Fall time	Ib=Ith, 20-80% <*>	---	0.1	0.2	ns
Im	Monitoring output current (PD)	CW, Po=5mW	0.05	0.2	---	mA
Id	Dark current (PD)	V _{RD} =5V	---	---	0.1	μA
Ct	Capacitance (PD)	V _{RD} =5V	---	10	20	pF

<*> Except influence of the 18mm lead.

ELECTRICAL/OPTICAL CHARACTERISTICS (Tc=25°C otherwise specified)

[Aspherical lens cap ; ML725J11F / ML720L11S]

Symbol	Parameter	Test conditions	Min.	Typ.	Max.	Unit
Ith	Threshold current	CW	---	6	12	mA
		CW, Tc=85°C	---	30	40	
Iop	Operation current	CW, Po=5mW	---	16	30	mA
		CW, Po=5mW, Tc=85°C	---	50	75	
Vop	Operating voltage	CW, Po=5mW	---	1.1	1.5	V
η	Slope efficiency	CW, Po=5mW	0.3	0.5	---	mW/mA
λp	Peak wavelength	CW, Po=5mW	1290	1310	1330	nm
SMSR	Side mode suppression ratio	CW, Po=5mW Tc= - 40 to +85°C	35	40	---	dB
Pf	Fiber coupling power	CW, Po=5mW, SMF	1.5	2.0	---	mW
Df	Focul length	CW, Po=5mW, SMF	6.5	7.5	8.5	mm
tr,tf	Rise and Fall time	Ib=Ith, 20-80% <*>	---	0.1	0.2	ns
Im	Monitoring output current (PD)	CW, Po=5mW	0.05	0.2	---	mA
Id	Dark current (PD)	V _{RD} =5V	---	---	0.1	μA
Ct	Capacitance (PD)	V _{RD} =5V	---	10	20	pF

<*> Except influence of the 18mm lead.

Notice : Some parametric limits are subject to change

OUTLINE DRAWINGS

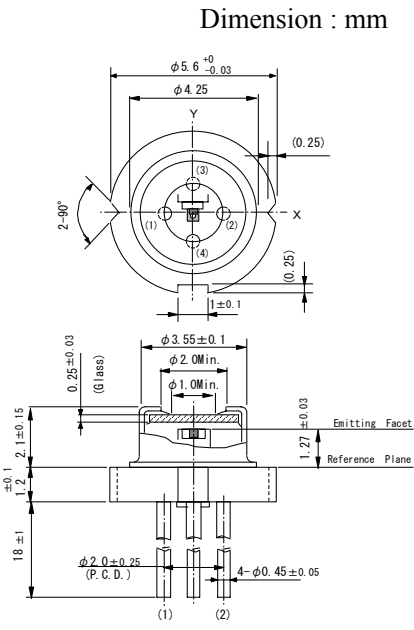
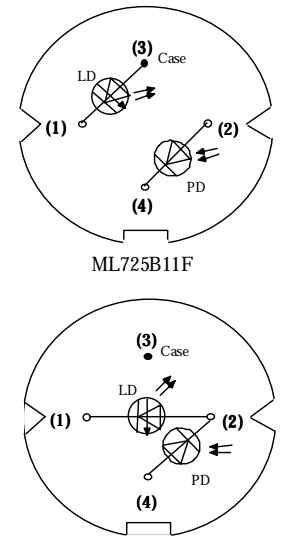
<p>ML725B11F ML720J11S</p> 	<p>Dimension : mm</p> 	 <p>ML725B11F</p> <p>ML720J11S Pin Connection (Top view)</p>
--	--	---

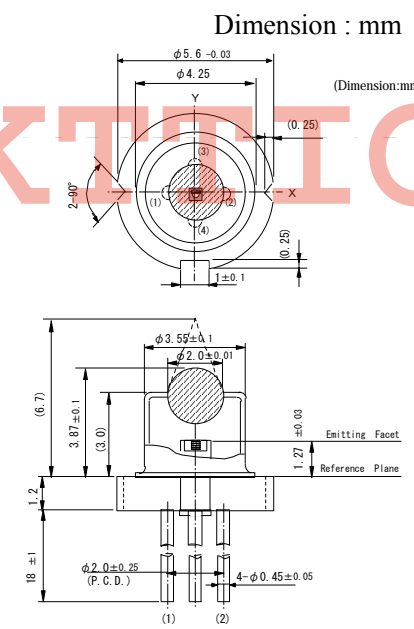
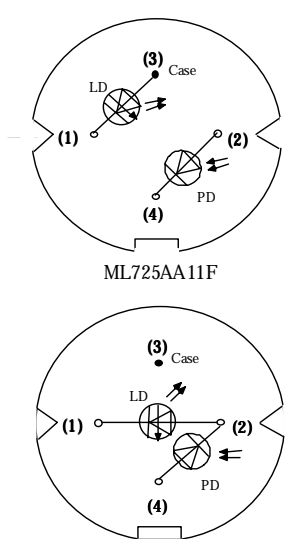
<p>ML725AA11F ML720AA11S</p> 	<p>Dimension : mm</p> 	 <p>ML725AA11F</p> <p>ML720AA11S Pin Connection (Top view)</p>
--	--	---

Notice : Some parametric limits are subject to change

OUTLINE DRAWINGS

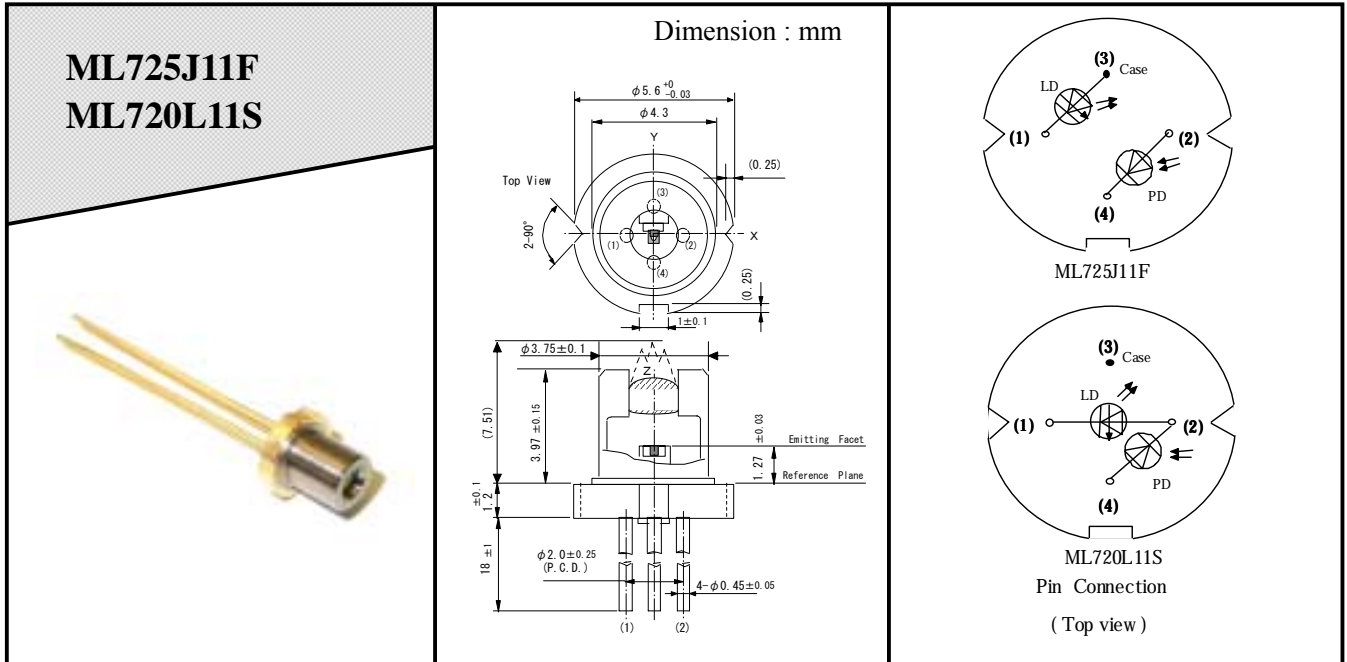

KTTIC