

M81016P/FP/KP

OCTAL D-TYPE FLIP-FLOP DRIVER WITH CLEAR

DESCRIPTION

M81016 is octal D-type flip-flop driver by 20-pin package. It has 8 same circuit units which is composed of D-type flip-flop logic circuit and high voltage NchMOS output transistor. M81016 has a common direct clear input and a common clock input.

FEATURES

- Lineup with three packages
- High breakdown voltage ($BV_{DS} \geq 40V$)
- Drain output current ($I_{DS(max)} = 200mA$)
- With input protection diodes
- Pin assignment of input-output flow through
- Wide operating temperature range ($T_a = -40$ to $+85^\circ C$)

APPLICATION

LED drive

FUNCTION

The common direct clear input and common clock input are connected to every circuit unit by the same way. Signal at the D inputs is transferred to \bar{Y} outputs by D-type flip-flops on the positive-going edge of the clock pulse.

If \overline{CLR} is set to "L", outputs $\bar{Y}1-\bar{Y}8$ will be altogether set to "H" regardless of D1-D8 and CLK.

The maximum drain current of an output is 200mA. The maximum between drain-source is 40V.

Moreover, M81016FP/KP can save space with mini-flat package.

PIN CONFIGURATION (TOP VIEW)

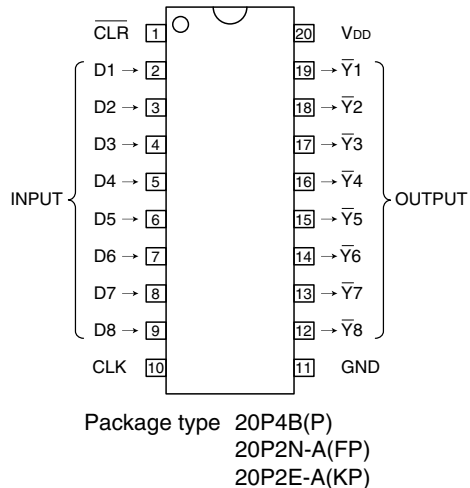

LOGIC DIAGRAM (POSITIVE LOGIC)

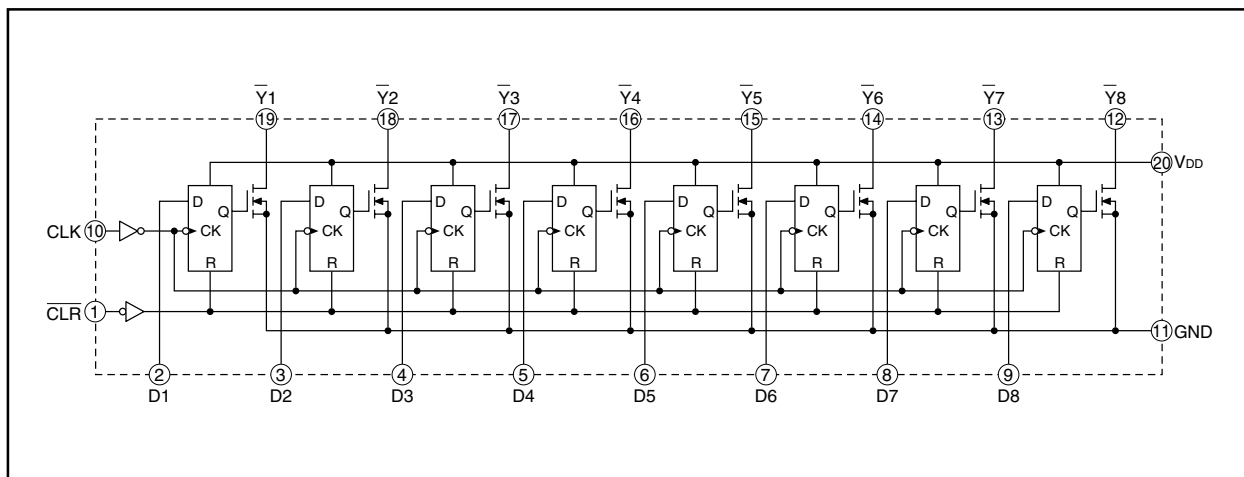

M81016P/FP/KP

OCTAL D-TYPE FLIP-FLOP DRIVER WITH CLEAR

FUNCTION TABLE (EACH CHANNEL)

INPUT			OUTPUT : \bar{Y}
$\overline{\text{CLR}}$	CLK	D	
L	X	X	H
H	\uparrow	L	H
H	\uparrow	H	L
H	L	X	Latched
H	\downarrow	X	Latched

H : High level

L : Low level

X : Irrelevant

TIMING DIAGRAM

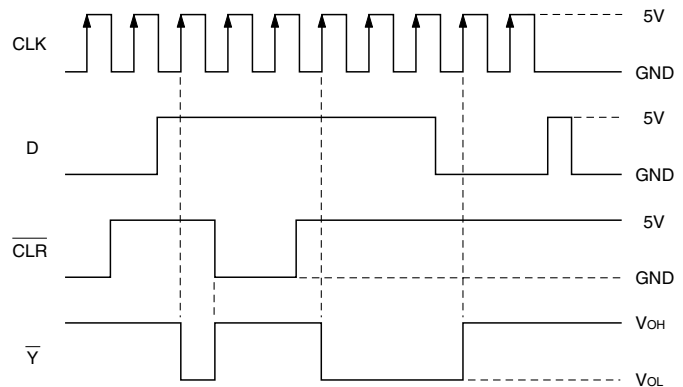

ABSOLUTE MAXIMUM RATINGS (Unless otherwise noted, Ta = -40 ~ +85°C)

Symbol	Parameter	Conditions	Ratings	Unit	
V _{DD}	Supply voltage		7	V	
V _{DS}	Drain-to-source voltage	Output, H	-0.5 ~ +40	V	
V _I	Input voltage		-0.5 ~ V _{DD}	V	
I _{DS}	Drain output current	Current per circuit output, L	200	mA	
P _d	Power dissipation	Ta = 25°C, when mounted on board	M81016P	1.47	W
			M81016FP	1.10	
			M81016KP	0.68	
T _{opr}	Operating temperature		-40 ~ +85	°C	
T _{stg}	Storage temperature		-55 ~ +125	°C	

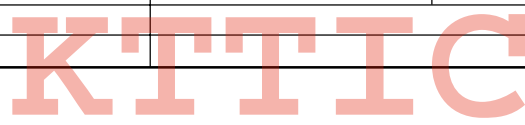

RECOMMENDED OPERATING CONDITIONS (Unless otherwise noted, Ta = -40 ~ +85°C)

Symbol	Parameter	Conditions	Limits			Unit	
			min	typ	max		
V _{DD}	Supply voltage		4.5	5.0	5.5	V	
V _{DS}	Drain-to-source voltage		0	—	40	V	
V _{IH}	"H" input voltage		0.7V _{DD}	—	V _{DD}	V	
V _{IL}	"L" input voltage		0	—	0.3V _{DD}	V	
I _{DS}	Drain output current (Current per 1 circuit when 8 circuits are coming on simultaneously)	P	Duty Cycle no more than 45%	0	—	200	mA
			Duty Cycle no more than 100%	0	—	135	
		FP	Duty Cycle no more than 34%	0	—	200	
			Duty Cycle no more than 100%	0	—	120	
		KP	Duty Cycle no more than 18%	0	—	200	
			Duty Cycle no more than 100%	0	—	95	
V _{IN}	Input voltage		0	—	V _{DD}	V	
t _r , t _f	Rise time, Fall time, drain output	V _{DD} = 4.5V	0	—	500	ns	
t _{su}	Setup time before CLK \uparrow	V _{DD} = 4.5V	20	—	—	ns	
t _h	Hold time, data after CLK \uparrow	V _{DD} = 4.5V	5	—	—	ns	
t _w	Pulse duration	V _{DD} = 4.5V	40	—	—	ns	
f	Clock frequency	V _{DD} = 4.5V	—	—	20	MHz	

M81016P/FP/KP

OCTAL D-TYPE FLIP-FLOP DRIVER WITH CLEAR

ELECTRICAL CHARACTERISTICS (Unless otherwise noted, $V_{DD} = 5V$, $T_a = 25^\circ C$)

Symbol	Parameter	Test conditions	Limits			Unit
			min	typ	max	
$V_{(BR)DSX}$	Drain-source breakdown voltage	$I_{DS} = 1mA$	40	—	—	V
I_{DSX}	Drain-source leakage current	$V_{DS} = 40V$	—	0.002	5	μA
I_{IH}	"H" input current	$V_{DD} = 5.5V, V_i = 5.5V$	—	0.005	1	μA
I_{IL}	"L" input current	$V_{DD} = 5.5V, V_i = 0V$	—	0.005	-1	μA
I_{CC}	Supply current	$V_{DD} = 5.5V$	All outputs off		5	μA
		$V_i = 5.5V$ or $0V$	All outputs on		5	
V_{DS}	"L" output voltage	$I_{DS} = 100mA, V_{DD} = 4.5V$	—	0.25	0.38	V
		$I_{DS} = 200mA, V_{DD} = 4.5V$	—	0.51	0.77	
$R_{DS(on)}$	Drain-source on-state resistance	$I_{DS} = 100mA, V_{DD} = 4.5V$	—	2.5	3.8	Ω

SWITCHING CHARACTERISTICS ($V_{DD} = 5V, T_a = 25^\circ C$)

Symbol	Parameter	Test conditions	Limits			Unit
			min	typ	max	
t_{TLH}	Low-level to high-level and high-level to low-level output transition time	$C_L = 30pF$ (Note 1)	—	10	—	ns
t_{THL}			—	3	—	ns
t_{PLH}	Low-level to high-level and high-level to low-level output propagation time (CLK)		—	35	—	ns
t_{PHL}			—	30	—	ns
$t_{PLH(R)}$	Low-level to high-level output propagation time (CLR)		—	35	—	ns

KTTIC

M81016P/FP/KP

OCTAL D-TYPE FLIP-FLOP DRIVER WITH CLEAR

NOTE 1 TEST CIRCUIT

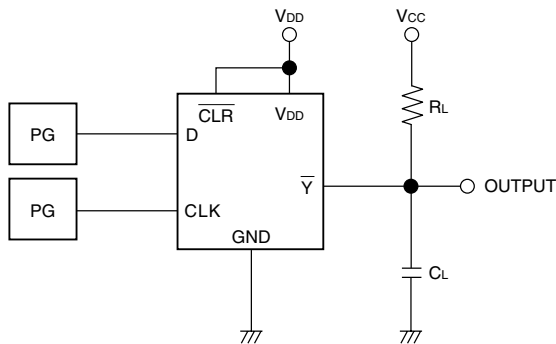

- (1) Pulse generator (PG) characteristics : PRR = 1MHz, Duty Cycle = 50%, $t_r = 6ns$, $t_f = 6ns$, $Z_o = 50\Omega$, $V_i = 5V$
- (2) Output conditions : $R_L = 240\Omega$, $V_{CC} = 24V$, $V_{DD} = 5V$
- (3) Electrostatic capacity C_L includes floating capacitance at connections and input capacitance at probes.

TIMING DIAGRAM

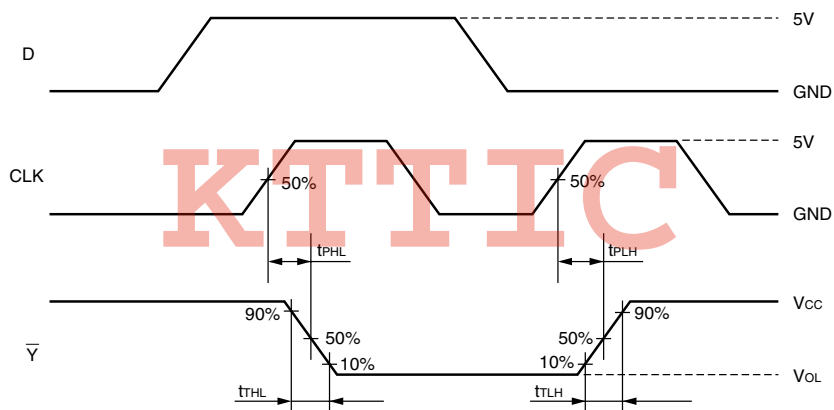

SWITCHING TIMES

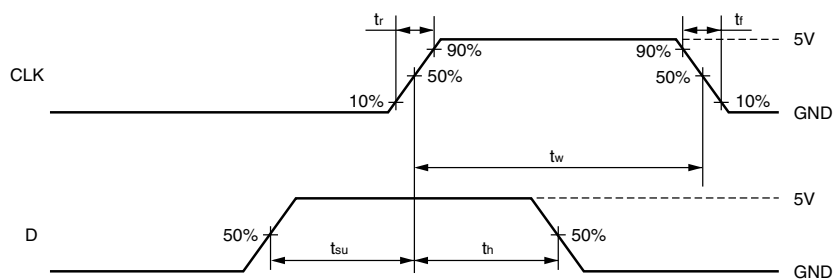

INPUT SETUP AND HOLD WAVEFORMS

M81016P/FP/KP

OCTAL D-TYPE FLIP-FLOP DRIVER WITH CLEAR

TYPICAL CHARACTERISTICS

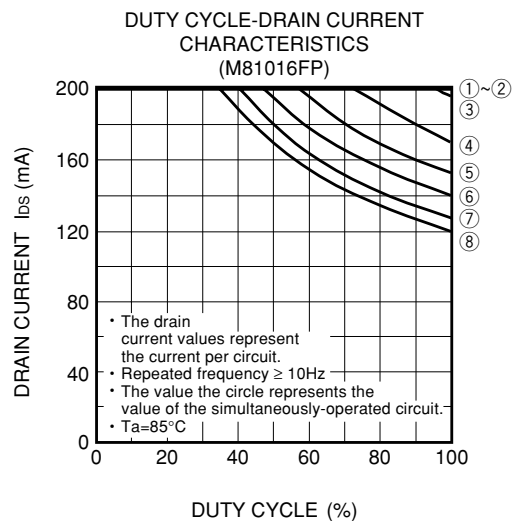
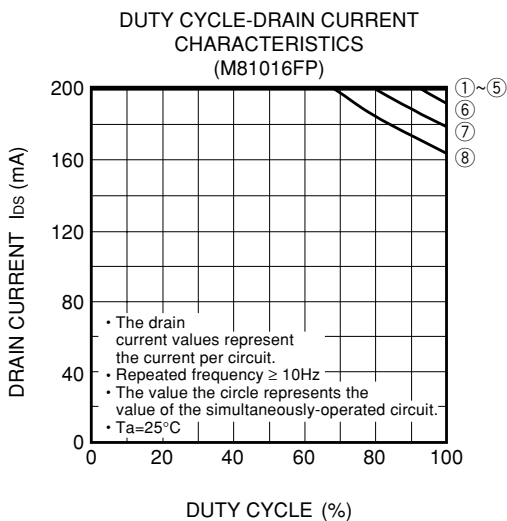
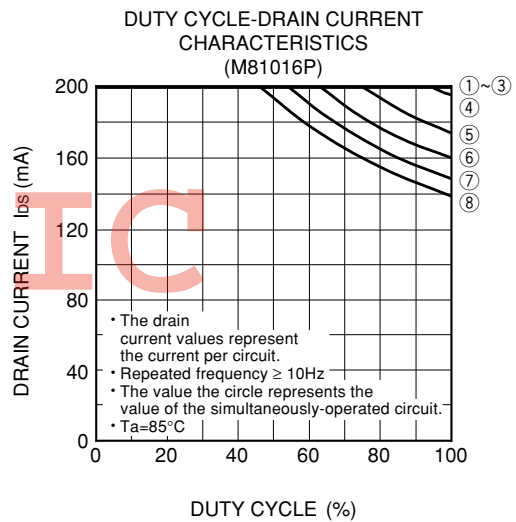
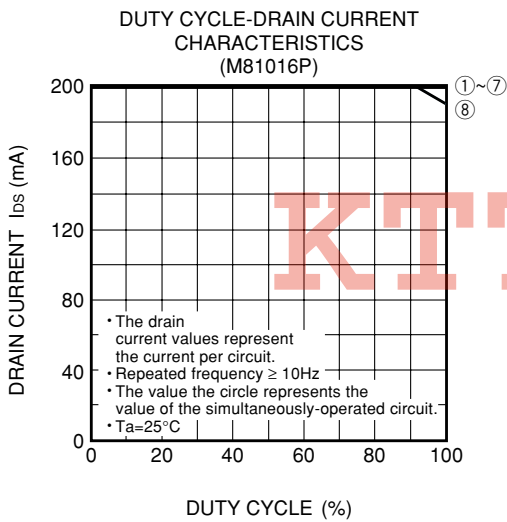
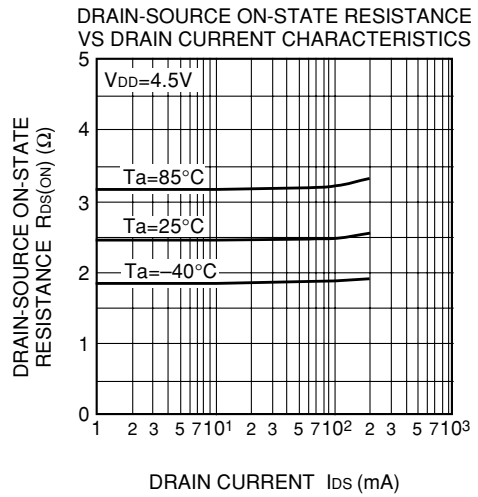
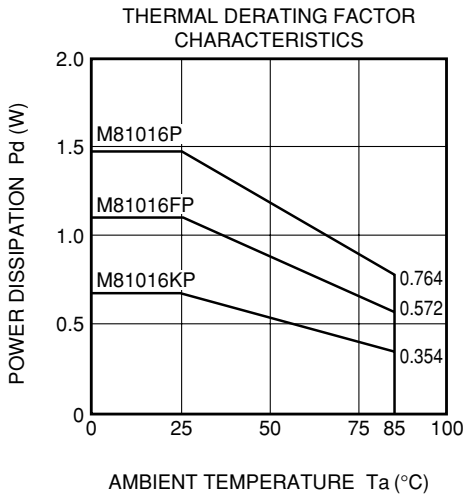

M81016P/FP/KP

OCTAL D-TYPE FLIP-FLOP DRIVER WITH CLEAR

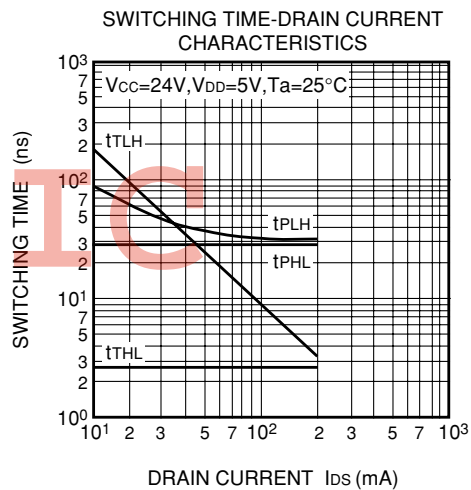
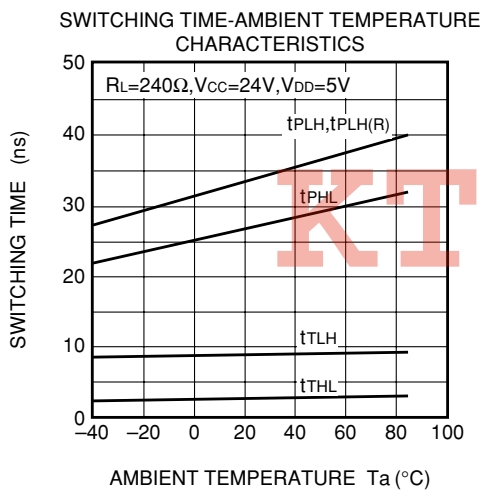
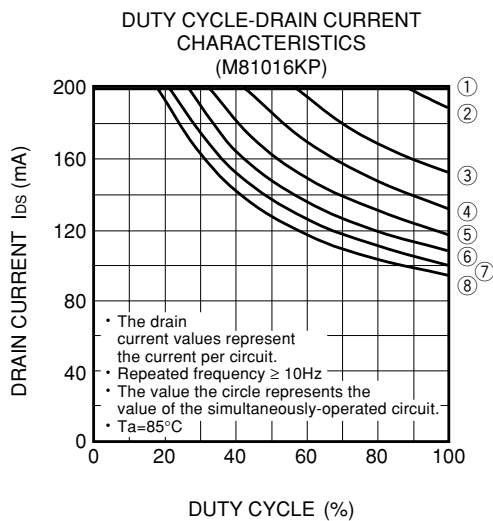
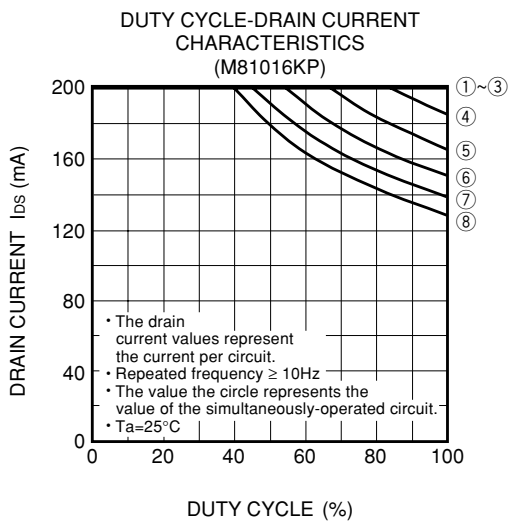

M81016P/FP/KP

OCTAL D-TYPE FLIP-FLOP DRIVER WITH CLEAR

20P4B

Plastic 20pin 300mil SDIP

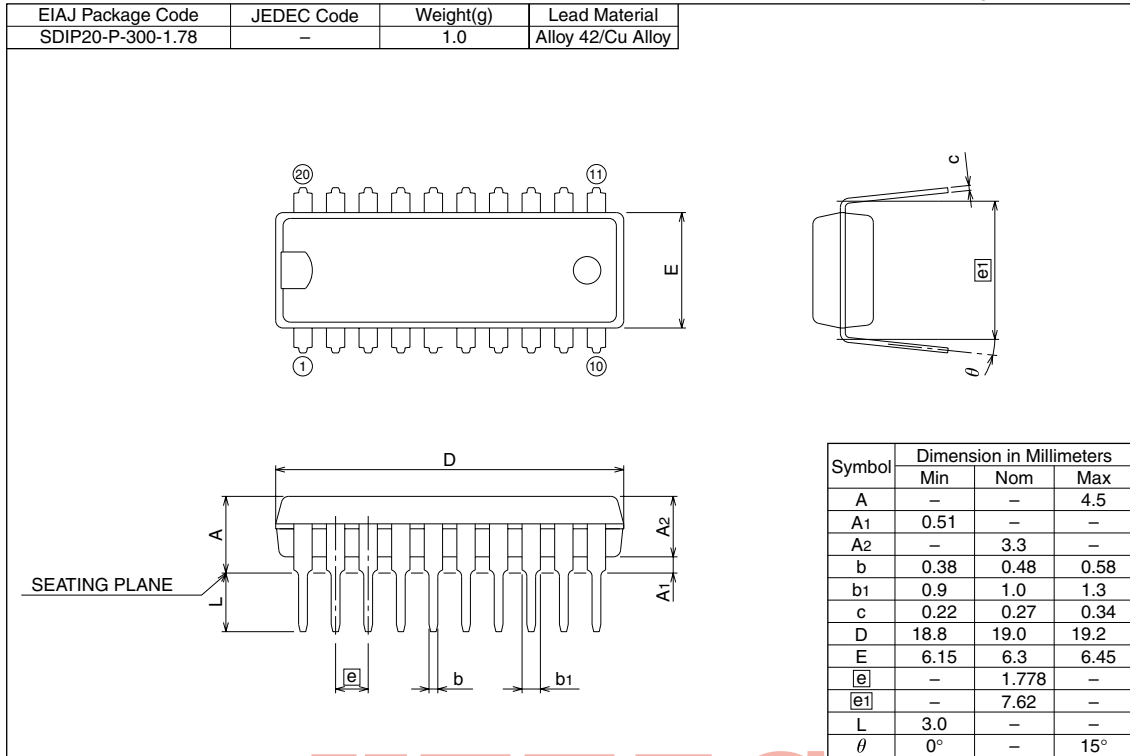

KTTIC

20P2N-A

Plastic 20pin 300mil SOP

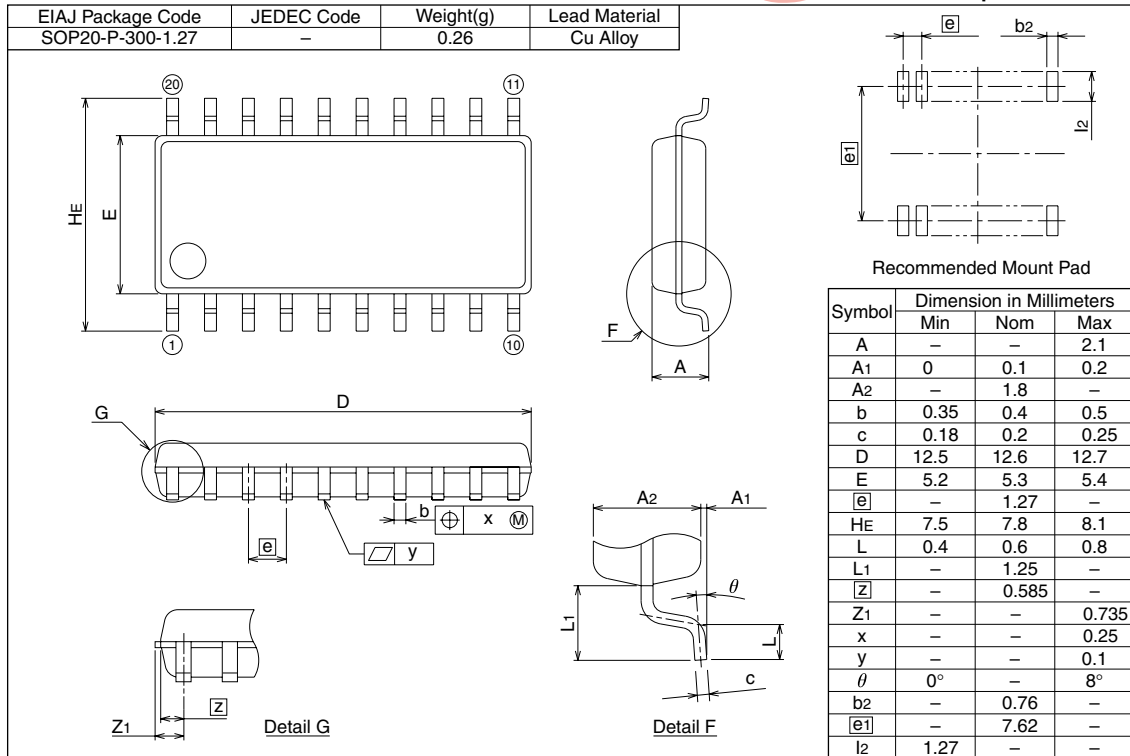

M81016P/FP/KP

OCTAL D-TYPE FLIP-FLOP DRIVER WITH CLEAR

20P2E-A

EIAJ Package Code	JEDEC Code	Weight(g)	Lead Material
SSOP20-P-225-0.65	-	0.08	Alloy 42

Plastic 20pin 225mil SSOP

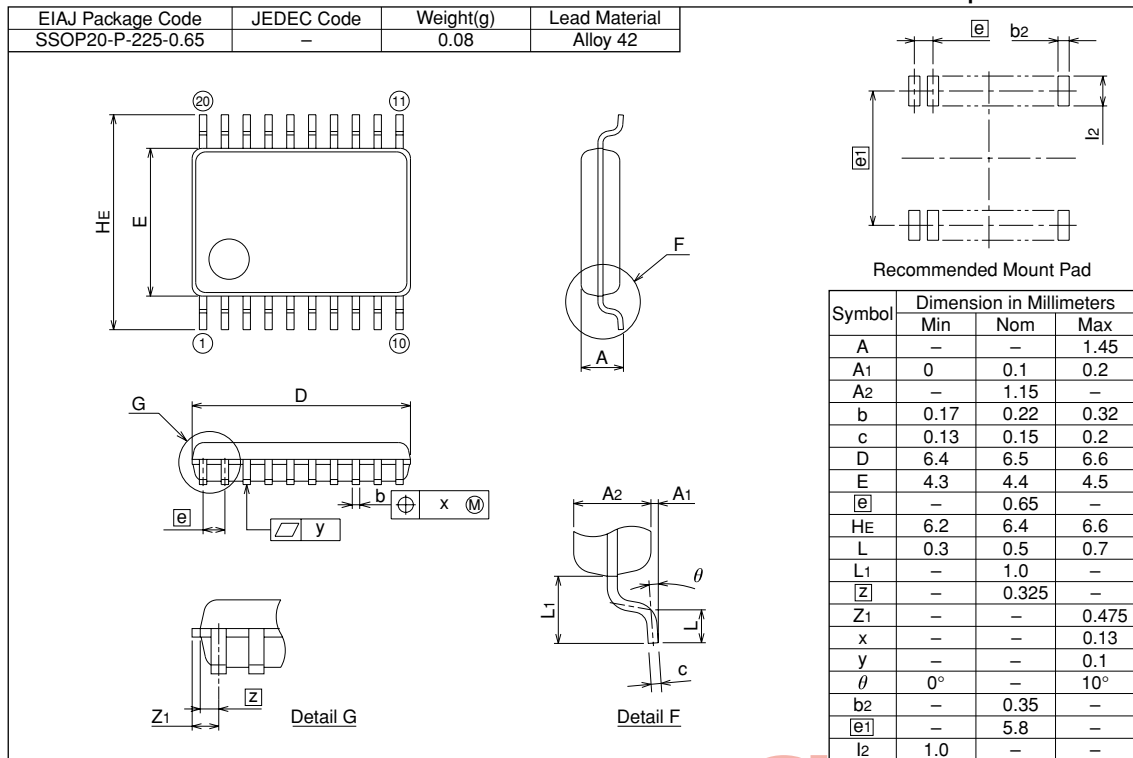

Recommended Mount Pad

Symbol	Dimension in Millimeters		
	Min	Nom	Max
A	-	-	1.45
A1	0	0.1	0.2
A2	-	1.15	-
b	0.17	0.22	0.32
c	0.13	0.15	0.2
D	6.4	6.5	6.6
E	4.3	4.4	4.5
e	-	0.65	-
HE	6.2	6.4	6.6
L	0.3	0.5	0.7
L1	-	1.0	-
L2	-	0.325	-
Z1	-	-	0.475
x	-	-	0.13
y	-	-	0.1
θ	0°	-	10°
b2	-	0.35	-
e1	-	5.8	-
l2	1.0	-	-

KTTIC