

SURMOUNT™ Low and Medium Barrier Silicon Schottky Diodes: Tee Pair

M/A-COM Products
 Rev. V5

Features

- Extremely Low Parasitic Capacitance and Inductance
- Surface Mountable in Microwave Circuits, No Wirebonds Required
- Rugged HMIC Construction with Polyimide Scratch Protection
- Reliable, Multilayer Metalization with a Diffusion Barrier, 100 % Stabilization Bake (300°C, 16 hours)
- Lower Susceptibility to ESD Damage

Description

The MA4E2514 SURMOUNT™ Diode Tee Series are Silicon Low, and Medium Barrier Schottky Devices fabricated with the patented Heterolithic Microwave Integrated Circuit (HMIC) process. HMIC Circuits consist of Silicon pedestals which form diodes or via conductors embedded in glass dielectric, which acts as the low dispersion, low loss microstrip transmission medium. The combination of silicon and glass allows HMIC devices to have excellent loss and power dissipation characteristics in a low profile, reliable device.

The Surmount Schottky devices are excellent choices for circuits requiring the small parasitics of a beam lead device coupled with the superior mechanical performance of a chip. The Surmount structure employs very low resistance silicon vias to connect the Schottky contacts to the metalized mounting pads on the bottom surface of the chip. These devices are reliable, repeatable, and a lower cost performance solution to conventional devices. They have lower susceptibility to electrostatic discharge than conventional beam lead Schottky diodes.

The multi-layer metallization employed in the fabrication of the Surmount Schottky junctions includes a platinum diffusion barrier, which permits all devices to be subjected to a 16-hour non-operating stabilization bake at 300°C.

The "0505" outline allows for Surface Mount placement and multi-functional polarity orientations.

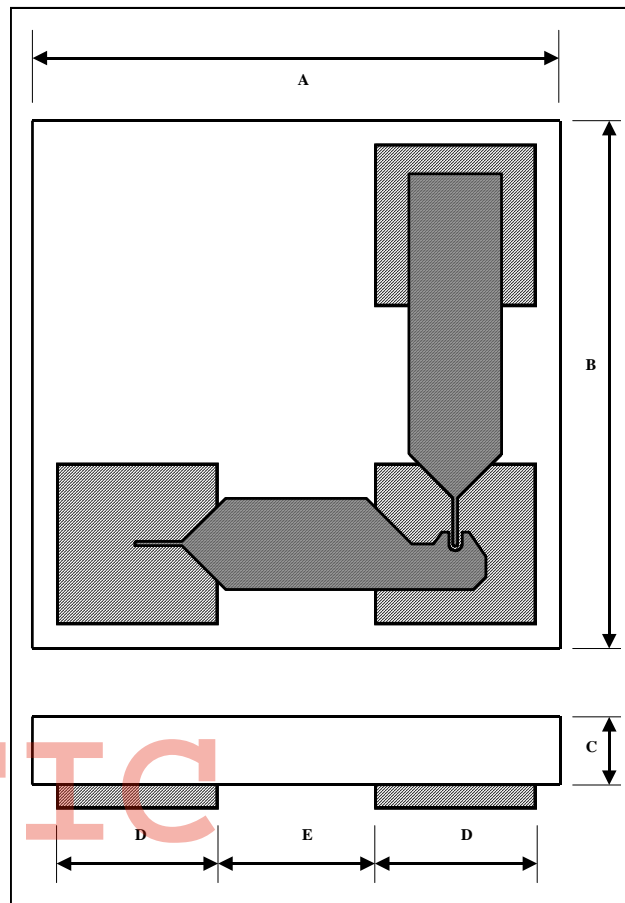

Case Style 1116

DIM	INCHES		MILLIMETERS	
	MIN.	MAX.	MIN.	MAX.
A	0.0445	0.0465	1.130	1.180
B	0.0445	0.0465	1.130	1.180
C	0.0040	0.0080	0.102	0.203
D Sq.	0.0128	0.0148	0.325	0.375
E	0.0128	0.0148	0.325	0.375

ADVANCED: Data Sheets contain information regarding a product M/A-COM is considering for development. Performance is based on target specifications, simulated results, and/or prototype measurements. Commitment to develop is not guaranteed.

PRELIMINARY: Data Sheets contain information regarding a product M/A-COM has under development. Performance is based on engineering tests. Specifications are typical. Mechanical outline has been fixed. Engineering samples and/or test data may be available. Commitment to produce in volume is not guaranteed.

- **North America** Tel: 800.366.2266 / Fax: 978.366.2266
- **Europe** Tel: 44.1908.574.200 / Fax: 44.1908.574.300
- **Asia/Pacific** Tel: 81.44.844.8296 / Fax: 81.44.844.8298

Visit www.macom.com for additional data sheets and product information.

M/A-COM Inc. and its affiliates reserve the right to make changes to the product(s) or information contained herein without notice.

**SURMOUNT™ Low and Medium Barrier Silicon
 Schottky Diodes: Tee Pair**

M/A-COM Products
 Rev. V5

Electrical Specifications @ 25°C (Measured as Single Diodes) ^{1,2,3}

Model Number	Type	Recommended Freq. Range	Vf @ 1 mA (mV)	Vb @ 10 uA (V)	Ct @ 0 V (pF)	Rt Slope Resistance (Vf1- Vf2)/ (10.5 mA - 9.5 mA) (Ω)
MA4E2514L	Low Barrier	DC - 18 GHz	330 Max 300 Typ	3 Min 5 Typ	0.12 Max 0.10 Typ	16 Typ 20 Max
MA4E2514M	Medium Barrier	DC - 18 GHz	470 Max 400 Typ	3 Min 5 Typ	0.12 Max 0.10 Typ	12 Typ 18 Max

1. Rt is the dynamic slope resistance where $R_t = R_s + R_j$, where $R_j = 26 / I_{dc}$ (I_{dc} is in mA) and R_s is the ohmic resistance.
2. Max Forward Voltage Difference ΔV_f @ 1 mA: 10 mV
3. Max Total Capacitance Difference ΔC_t @ 0 V: 0.03 pF

Applications

The MA4E2514 Family of Surmount Schottky diodes are recommended for use in microwave circuits through Ku band frequencies for lower power applications such as mixers, sub-harmonic mixers, detectors and limiters. The HMIC construction facilitates the direct replacement of more fragile beam lead diodes with the corresponding Surmount diode, which can be connected to a hard or soft substrate circuit with solder.

Handling

All semiconductor chips should be handled with care to avoid damage or contamination from perspiration and skin oils. The use of plastic tipped tweezers or vacuum pickups is strongly recommended for individual components. The top surface of the die has a protective polyimide coating to minimize damage.

The rugged construction of these Surmount devices allows the use of standard handling and die attach techniques. It is important to note that industry standard electrostatic discharge (ESD) control is required at all times, due to the sensitive nature of Schottky junctions. Bulk handling should insure that abrasion and mechanical shock are minimized.

Die Bonding

Die attach for these devices is made simple through the use of surface mount die attach technology. Mounting pads are conveniently located on the bottom surface of these devices, and are opposite the active junction. The devices are well suited for high temperature solder attachment onto hard substrates.

Absolute Maximum Ratings ⁴

Parameter	Value
Operating Temperature	-40°C to +150°C
Storage Temperature	-40°C to +150°C
Forward Current	20 mA
Reverse Voltage	5 V
RF C.W. Incident Power	+ 20 dBm
RF & DC Dissipated Power	50 mW
Electrostatic Discharge (ESD) Classification ⁵	Class 0

4. Exceeding any of these values may result in permanent damage.
5. Human Body Model

Die Bonding

For Hard substrates, we recommend utilizing a vacuum tip and force of 60 to 100 grams applied uniformly to the top surface of the device, using a hot gas bonder with equal heat applied across the bottom mounting pads of the device. When soldering to soft substrates, it is recommended to use a lead-tin interface at the circuit board mounting pads. Position the die so that its mounting pads are aligned with the circuit board mounting pads. Reflow the solder paste by applying equal heat to the circuit at both die-mounting pads. The solder joint must not be made one at a time, creating unequal heat flow and thermal stress. Solder reflow should not be performed by causing heat to flow through the top surface of the die. Since the HMIC glass is transparent, the edges of the mounting pads can be visually inspected through the die after the die attach is completed.

ADVANCED: Data Sheets contain information regarding a product M/A-COM is considering for development. Performance is based on target specifications, simulated results, and/or prototype measurements. Commitment to develop is not guaranteed.

PRELIMINARY: Data Sheets contain information regarding a product M/A-COM has under development. Performance is based on engineering tests. Specifications are typical. Mechanical outline has been fixed. Engineering samples and/or test data may be available. Commitment to produce in volume is not guaranteed.

- **North America** Tel: 800.366.2266 / Fax: 978.366.2266
 - **Europe** Tel: 44.1908.574.200 / Fax: 44.1908.574.300
 - **Asia/Pacific** Tel: 81.44.844.8296 / Fax: 81.44.844.8298
- Visit www.macom.com for additional data sheets and product information.

M/A-COM Inc. and its affiliates reserve the right to make changes to the product(s) or information contained herein without notice.

**SURMOUNT™ Low and Medium Barrier Silicon
 Schottky Diodes: Tee Pair**

M/A-COM Products
 Rev. V5

MA4E2514L Low Barrier SPICE PARAMETERS (Per Diode)⁵

Is (nA)	Rs (Ω)	N	Cj0 (pF)	M	Ik (mA)	Cjpar (pF)	Vj (V)	FC	BV (V)	IBV (mA)
26	12.8	1.20	1.0 E-2	0.5	14	9.0 E-2	8.0 E-2	0.5	5.0	1.0 E-2

MA4E2514L Medium Barrier SPICE PARAMETERS (Per Diode)⁵

Is (nA)	Rs (Ω)	N	Cj0 (pF)	M	Ik (mA)	Cjpar (pF)	Vj (V)	FC	BV (V)	IBV (mA)
5 E-1	9.6	1.20	1.0 E-2	0.5	10	9.0 E-2	8.0 E-2	0.5	5.0	1.0 E-2

5. Spice parameters (Per Diode) are based on the MA4E2502 Series datasheet.

Circuit Mounting Dimensions (Inches)

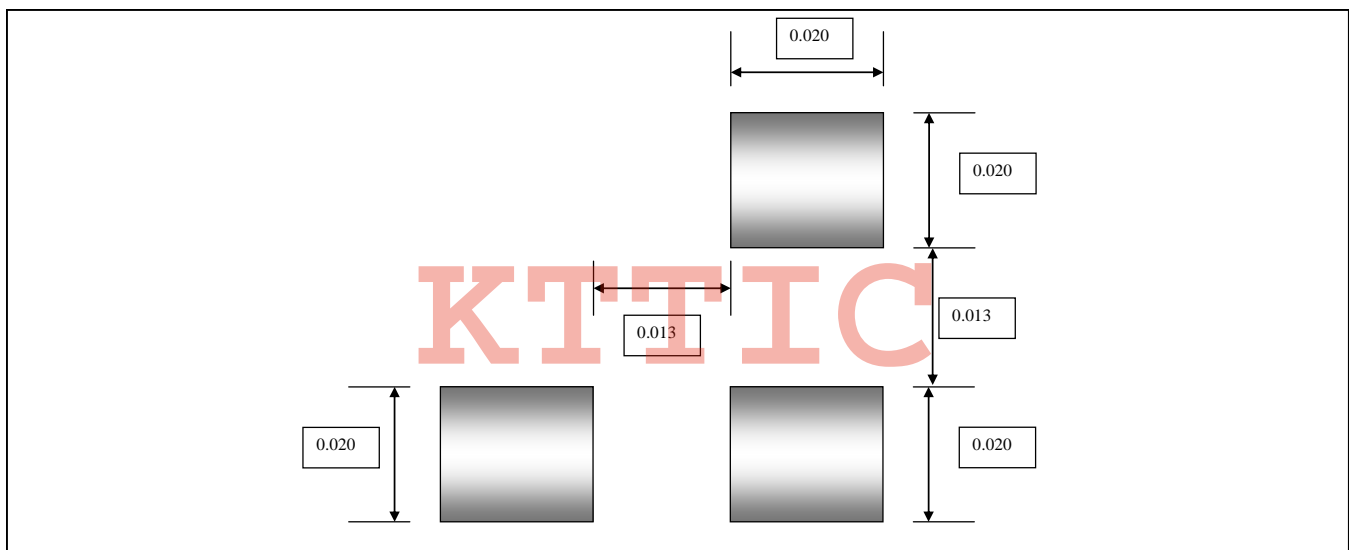

Ordering Information

Part Number	Packaging
MA4E2514L-1116W	Wafer on Frame
MA4E2514L-1116	Die in Carrier
MA4E2514L-1116T	Surf Tape
MADS-002514-1116LP	Pocket Tape on Reel
MA4E2514M-1116W	Wafer on Frame
MA4E2514M-1116	Die in Carrier
MA4E2514M-1116T	Surf Tape
MADS-002514-1116MP	Pocket Tape on Reel

ADVANCED: Data Sheets contain information regarding a product M/A-COM is considering for development. Performance is based on target specifications, simulated results, and/or prototype measurements. Commitment to develop is not guaranteed.

PRELIMINARY: Data Sheets contain information regarding a product M/A-COM has under development. Performance is based on engineering tests. Specifications are typical. Mechanical outline has been fixed. Engineering samples and/or test data may be available. Commitment to produce in volume is not guaranteed.

- **North America** Tel: 800.366.2266 / Fax: 978.366.2266
- **Europe** Tel: 44.1908.574.200 / Fax: 44.1908.574.300
- **Asia/Pacific** Tel: 81.44.844.8296 / Fax: 81.44.844.8298

Visit www.macom.com for additional data sheets and product information.

M/A-COM Inc. and its affiliates reserve the right to make changes to the product(s) or information contained herein without notice.

MA4E2514 Schematic Per Diode

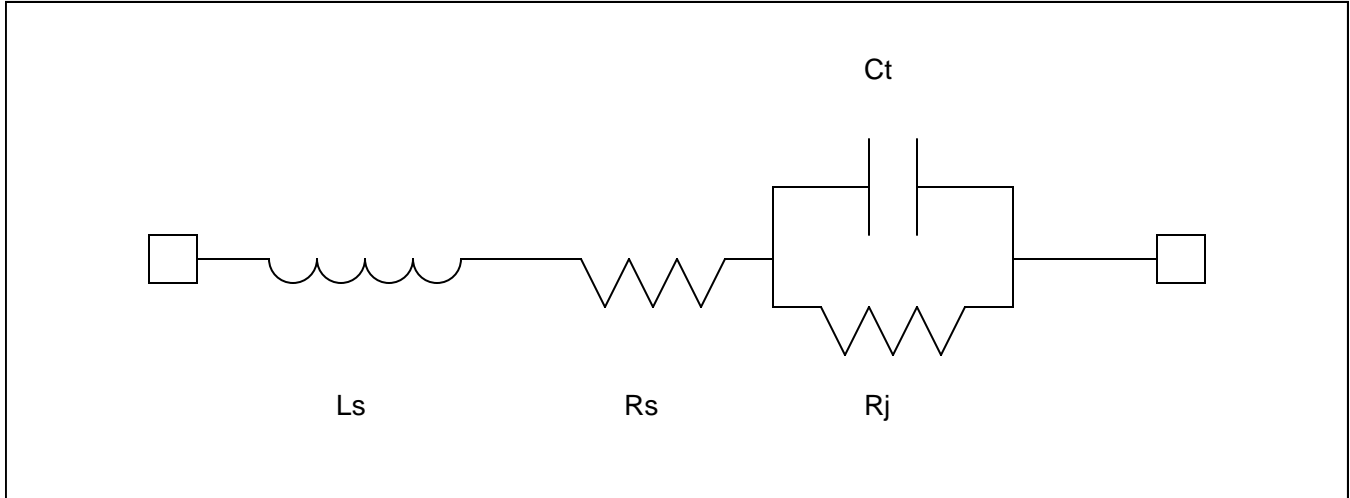

Schematic Values per Diode

Model Number	Ls (nH)	Rs (Ω)	Rj (Ω)	Ct (pF)
MA4E2514L	0.7	13.4	26 / I _{dc}	0.10
MA4E2514M	0.7	9.4	26 / I _{dc}	0.10

MA4E2514 Equivalent Circuit

