

INNOLUX DISPLAY CORPORATION **LCD MODULE** **SPECIFICATION**

Customer: _____

Model Name: AT043TN13 V.10

SPEC NO.: A043-13-TT-101

Date: 2006/08/02

Version: 02

- Preliminary Specification
- Final Specification

For Customer's Acceptance

Approved by	Comment

Approved by	Reviewed by	Prepared by

INNOLUX DISPLAY CORPORATION

LCD MODULE SPECIFICATION

Customer: _____

Model Name: AT043TN13 V.10

SPEC NO.: A043-13-TT-101

Date: 2006/08/02

Version: 02

Preliminary Specification

Final Specification

For Customer's Acceptance

Approved by	Comment

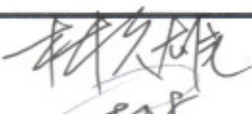
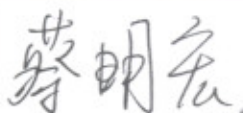
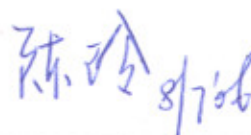
Approved by	Reviewed by	Prepared by
 1061549	 8/8/06	 8/7/06

Contents

1.	General Specifications	1
2.	Pin Assignment	2
2.1.	TFT LCD Panel Driving Section.....	2
2.2.	Backlight Unit Section.....	4
3.	Operation Specifications	5
3.1.	Absolute Maximum Rating.....	5
3.1.1.	Typical Operation Conditions.....	6
3.1.2.	Current Consumption	7
3.1.3.	Backlight Driving Conditions.....	7
3.2.	Power Sequence	8
3.3.	Timing Characteristics	9
3.3.1.	Timing Conditions.....	9
3.3.2.	Timing Diagram	11
4.	Touch Screen Panel Specifications	13
4.1.	Electrical Characteristics	13
4.2.	Mechanical & Reliability Characteristics	13
4.3.	Touch Screen Panel Block.....	14
4.4.	Touch Screen Panel Pin Definition	14
5.	Optical Specifications.....	15
6.	Reliability Test Items	19
7.	General Precautions	20
7.1.	Safety	20
7.2.	Handling	20
7.3.	Static Electricity	20
7.4.	Storage	20
7.5.	Cleaning	20
8.	Mechanical Drawing.....	21
9.	Package Drawing.....	22

1. General Specifications

No.	Item	Specification	Remark
1	LCD size	4.3 inch(Diagonal)	
2	Driver element	a-Si TFT active matrix	
3	Resolution	480X3(RGB)X272	
4	Display mode	Normally White, Transmissive	
5	Dot pitch	0.066(W)X0.198(H) mm	
6	Active area	95.04(W)X53.856(H) mm	
7	Module size	105.5(W)X67.2(H)X4.95(D) mm	Note 1
8	Surface treatment	Anti-Glare	
9	Color arrangement	RGB-stripe	
10	Interface	Digital	
11	Backlight Power consumption	TBD	
12	Panel Power consumption	TBD	
13	Weight	TBD	

Note 1: Refer to Mechanical Drawing.

2. Pin Assignment

2.1. TFT LCD Panel Driving Section

Pin No.	Symbol	I/O	Function	Remark
1	GND	P	Power ground	
2	GND	P	Power ground	
3	V _{DD}	P	Power supply	
4	V _{DD}	P	Power supply	
5	R0	I	Red data (LSB)	
6	R1	I	Red data	
7	R2	I	Red data	
8	R3	I	Red data	
9	R4	I	Red data	
10	R5	I	Red data	
11	R6	I	Red data	
12	R7	I	Red data (MSB)	
13	G0	I	Green data (LSB)	
14	G1	I	Green data	
15	G2	I	Green data	
16	G3	I	Green data	
17	G4	I	Green data	
18	G5	I	Green data	
19	G6	I	Green data	
20	G7	I	Green data (MSB)	

21	B0	I	Blue data (LSB)	
22	B1	I	Blue data	
23	B2	I	Blue data	
24	B3	I	Blue data	
25	B4	I	Blue data	
26	B5	I	Blue data	
27	B6	I	Blue data	
28	B7	I	Blue data (MSB)	
29	GND	P	Power ground	
30	PCLK	P	Pixel clock	
31	DISP	I	Display on/off	
32	HSYNC	I	Horizontal Sync Signal	
33	VSYNC	I	Vertical Sync Signal	
34	DE	I	Data Enable	
35	AV _{DD}	P	Power supply (+5V)	
36	AV _{DD}	P	Power supply (+5V)	
37	NC	-	No connection	
38	NC	-	No connection	
39	GND	P	Power ground	
40	GND	P	Power ground	

I: input, O: output, P: Power

2.2. Backlight Unit Section

Pin No.	Symbol	I/O	Function	Remark
1	VLED 1-	P	Ground (cathode)	
2	VLED 2-	P	Ground (cathode)	
3	VLED 2+	P	LED Input terminal (anode)	
4	VLED 1+	P	LED Input terminal (anode)	

KTTIC

3. Operation Specifications

3.1. Absolute Maximum Rating

(GND=AV_{SS}=0V, Note 1)

Item	Symbol	Values		Unit	Remark
		Min.	Max.		
Power voltage	V _{DD}	-0.3	6.0	V	
	AV _{DD}	-0.3	6.0	V	
Input signal voltage	Logic input	-0.3	V _{DD} +0.3	V	
Operation Temperature	T _{OP}	(-20)	(70)	°C	
Storage Temperature	T _{ST}	(-30)	(80)	°C	

Note 1: The absolute maximum rating values of this product are not allowed to be exceeded at any times. Should a module be used with any of the absolute maximum ratings exceeded, the characteristics of the module may not be recovered, or in an extreme case, the module may be permanently destroyed.

3.1.1. Typical Operation Conditions

(GND=AV_{SS}=0V, Note 1)

Item	Symbol	Values			Unit	Remark
		Min.	Typ.	Max.		
Power voltage	V _{DD}	2.3	2.5	2.7	V	Note 2
		3.1	3.3	3.5	V	
	AV _{DD}	4.8	5.0	5.2	V	
Input logic high voltage	V _{IH}	0.7V _{DD}	-	V _{DD}	V	
Input logic low voltage	V _{IL}	0	-	0.3V _{DD}	V	

Note 1: Be sure to apply V_{DD} and V_{GL} to the LCD first, and then apply V_{GH}.

Note 2: You should choose only one from the typical values of V_{DD}.

KTTIC

3.1.2. Current Consumption

(GND=AV_{SS}=0V)

Item	Symbol	Values			Unit	Remark
		Min.	Typ.	Max.		
Current for Driver	I _{DD}	-	TBD	TBD	mA	V _{DD} =2.5V
	I _{AV_{DD}}	-	TBD	TBD	mA	AV _{DD} =5.0V

3.1.3. Backlight Driving Conditions

Item	Symbol	Values			Unit	Remark
		Min.	Typ.	Max.		
LED voltage	V _L	-	19.8	21.0	V	Note 2
LED current	I _L	-	(16)	-	mA	Note 2
LED life time	-	20,000	-	-	Hr	Note 1

Note 1: The “LED life time” is defined as the module brightness decrease to 50% original brightness that the ambient temperature is 25°C and I_L =16mA.

Note 2: The LED driving condition is defined for each LED module (6 LED Serial).

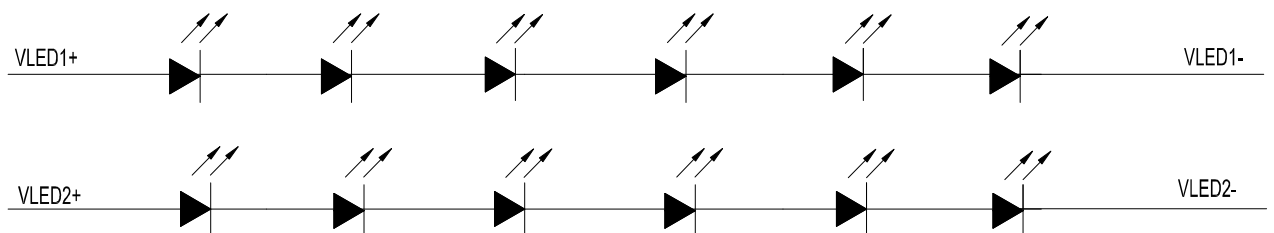

3.2. Power Sequence

To prevent a latch-up or DC operation of the LCD module, the power on/off sequence should be as the diagram below.

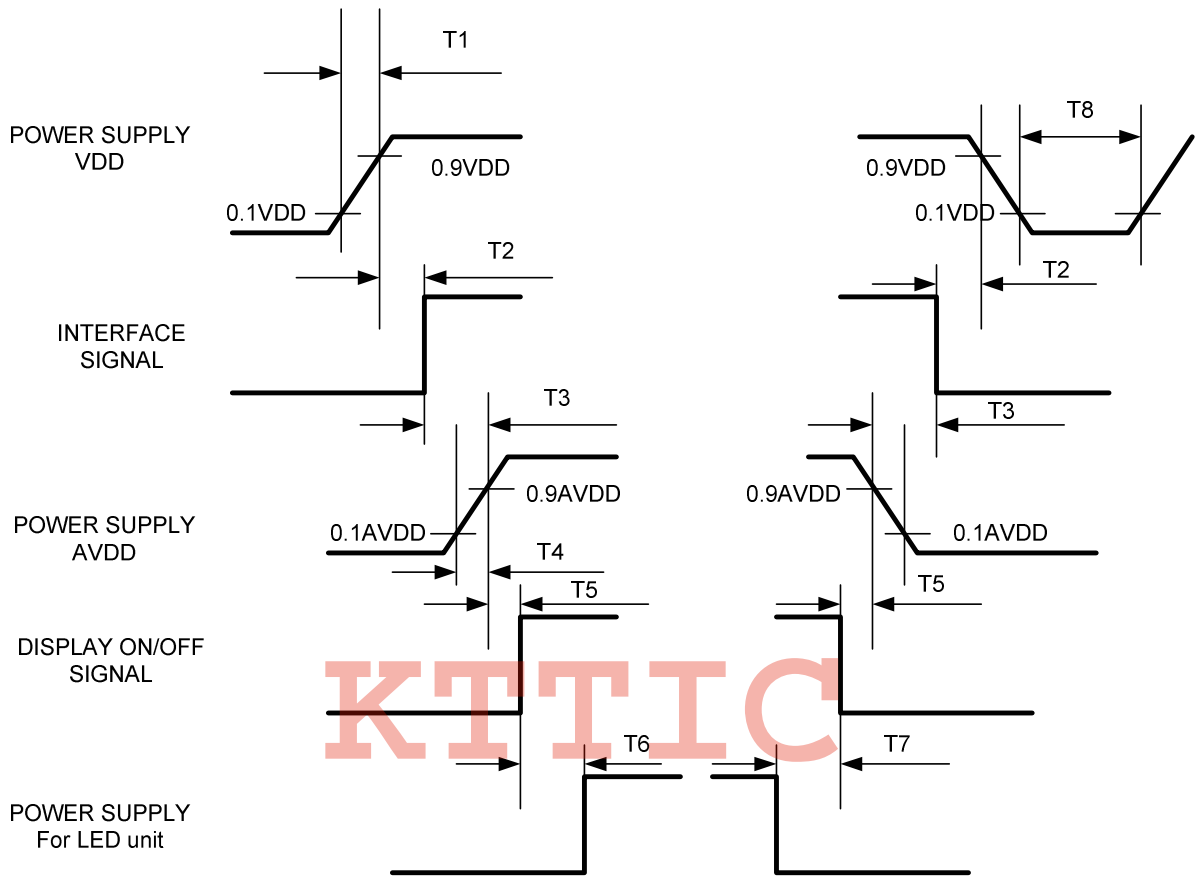

Symbol	Specification	Symbol	Specification
T1	$0 \leq T1 \leq 10 \text{ msec}$	T5	$0 \leq T5 \leq 160 \text{ msec}$
T2	$0 \leq T2 \leq 100 \text{ msec}$	T6	$160 \text{ msec} \leq T6$
T3	$0 \leq T3 \leq 50 \text{ msec}$	T7	$160 \text{ msec} \leq T7$
T4	$0 \leq T4 \leq 10 \text{ msec}$	T8	$1 \text{ msec} \leq T8$

3.3. Timing Characteristics

3.3.1. Timing Conditions

(TA = 25°C, VDD = 2.3V~3.5V, GND = 0V)

Item	Symbol	Values			Unit	Remark
		Min.	Typ.	Max.		
Clock cycle	1/tc	-	9.00	15	MHz	
Hsync cycle	1/fH	-	17.14	-	KHz	
Vsync cycle	1/fv	-	59.94	-	Hz	
Horizontal signal	t _h	-	525	-	CLK	Note 1
Horizontal display period	t _{hd}	-	480	-	CLK	
Horizontal Front porch	t _{hf}	2	-	-	CLK	Note 2
Horizontal Pulse width	t _{hp}	2	41	-	CLK	Note 2
Horizontal Back porch	t _{hb}	2	-	-	CLK	Note 2
Vertical cycle	t _v	-	286	-	H	
Vertical display period	t _{vd}	-	272	-	H	
Vertical Front porch	t _{vf}	2	2	-	H	
Vertical Pulse width	t _{vp}	2	10	-	H	
Vertical Back porch	t _{vb}	2	2	-	H	
DISP Setup Time	t _{diss}	10	-	-	ns	
DISP Hold Time	t _{dish}	10	-	-	ns	
Clock Period	PW CLK	66.7	-	-	ns	
Clock Pulse High Period	PWH	26.7	-	-	ns	
Clock Pulse Low Period	PWL	26.7	-	-	ns	
Hsync Setup Time	t _{hs}	10	-	-	ns	
Hsync Hold Time	t _{hh}	10	-	-	ns	

Data Setup Time	t _{ds}	10	-	-	ns	
Data Hold Time	t _{dh}	10	-	-	ns	
DE Setup Time	t _{des}	10	-	-	ns	
DE Hold Time	t _{desh}	10	-	-	ns	
Vsync Setup Time	t _{vhs}	10	-	-	ns	
Vsync Hold Time	t _{vhh}	10	-	-	ns	

Note 1: t_{hd}=480CLK, t_{hf}= 2CLK, t_{hp}= 41CLK, t_{hb}= 2CLK
 525CLK=480CLK + 2CLK + 41CLK + 2CLK

Note 2: t_{hf}+ t_{hp}+ t_{hb}> 44 CLK

KTTIC

3.3.2. Timing Diagram

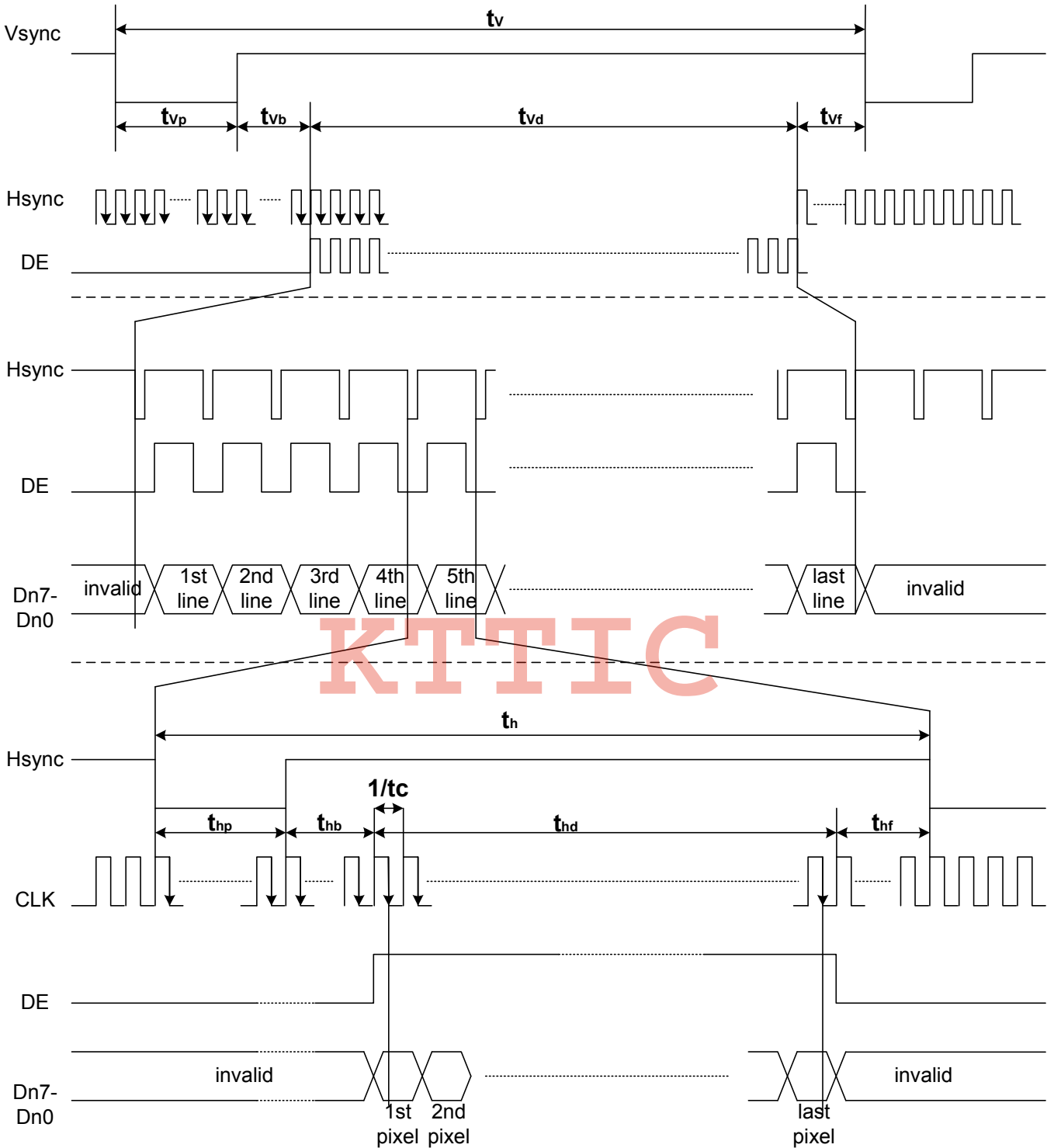

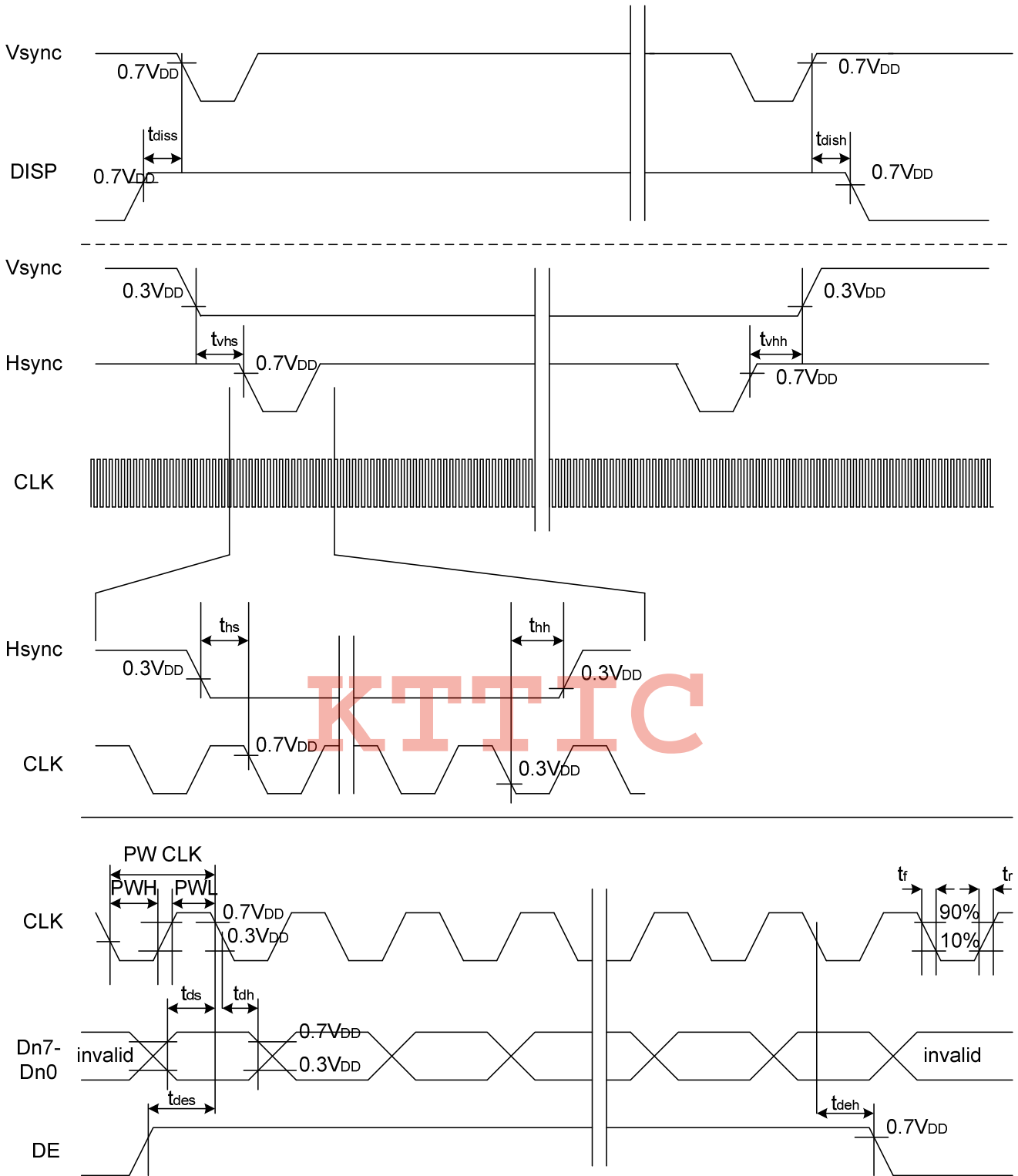

4. Touch Screen Panel Specifications

4.1. Electrical Characteristics

Item	Value			Unit	Remark
	Min.	Typ.	Max.		
Linearity	-1.5	-	1.5	%	Analog X and Y directions
Terminal Resistance	100	-	900	Ω	X(Film side)
	100	-	900	Ω	Y(Glass side)
Insulation resistance	25	-	-	MΩ	DC 25V
Voltage	-	5	7	V	DC
Chattering	-	-	10	ms	100kΩ pull-up
Transparency	79	-	-	%	JIS K7105

Note: Do not operate it with a thing except a polyacetal pen (tip R0.8mm or less) or a finger, especially those with hard or sharp tips such as a ball point pen or a mechanical pencil.

4.2. Mechanical & Reliability Characteristics

Item	Value			Unit	Remark
	Min.	Typ.	Max.		
Activation force	80	-	-	g	Note 1
Durability-surface scratching	Write 100,000	-	-	characters	Note 2
Durability-surface pitting	1,000,000	-	-	touches	Note 3
Surface hardness	3	-	-	H	JIS K5400

Note 1: Stylus pen input: R0.8mm polyacetal pen or finger.

Note 2: Measurement for surface area.

-Scratch 100,000 times straight line on the film with a stylus change every 20,000

The copyright belongs to InnoLux. Any unauthorized use is prohibited.

- times.
- Force: 250gf.
- Speed: 60mm/sec.
- Stylus: R0.8 polyacetal tip.

Note 3: Pit 1,000,000 times on the film with a R0.8 silicon rubber.

- Force: 250gf.
- Speed: 2times/sec.

4.3. Touch Screen Panel Block

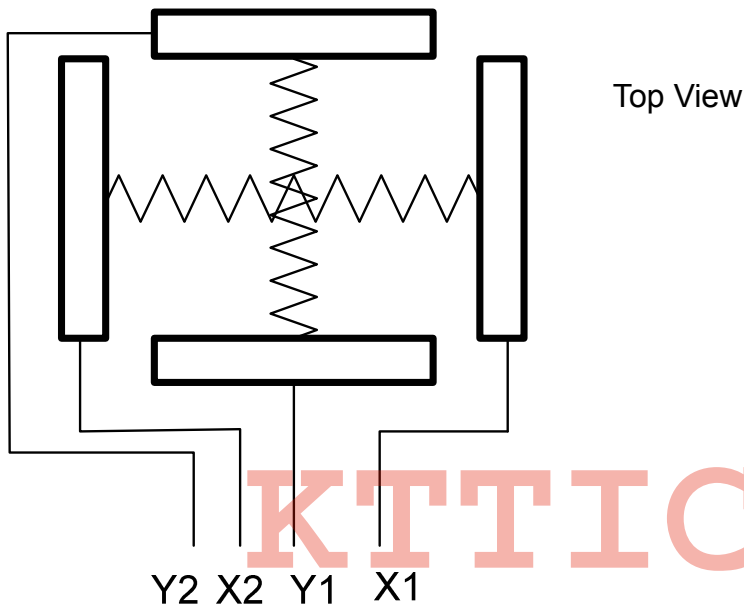

4.4. Touch Screen Panel Pin Definition

Pin No.	Symbol	I/O	Function	Remark
1	Y2	Top	Top electrode – differential analog	
2	X2	Left	Left electrode – differential analog	
3	Y1	Bottom	Bottom electrode – differential analog	
4	X1	Right	Right electrode – differential analog	

5. Optical Specifications

Item	Symbol	Condition	Values			Unit	Remark
			Min.	Typ.	Max.		
Viewing angle (CR≥ 10)	θ_L	$\Phi=180^\circ$ (9 o'clock)	(60)	(70)	-	degree	Note 1
	θ_R	$\Phi=0^\circ$ (3 o'clock)	(60)	(70)	-		
	θ_T	$\Phi=90^\circ$ (12 o'clock)	(40)	(50)	-		
	θ_B	$\Phi=270^\circ$ (6 o'clock)	(60)	(70)	-		
Response time	T_{ON}	Normal $\theta=\Phi=0^\circ$	-	(10)	(20)	msec	Note 3
	T_{OFF}		-	(15)	(30)	msec	Note 3
Contrast ratio	CR		(400)	(500)	-	-	Note 4
Color chromaticity	W_X		(0.26)	(0.31)	(0.36)	-	Note 2 Note 5 Note 6
	W_Y		(0.28)	(0.33)	(0.38)	-	
Luminance	L_1		(230)	(280)	-	cd/m ²	Note 6 (With touch screen)
	L_2		(300)	(350)	-	cd/m ²	Note 6 (Without touch screen)
Luminance uniformity	Y_U	70	75	-	%	Note 7	

Test Conditions:

1. $V_{DD}=3.3V$, $I_L=16mA$ (Backlight current), the ambient temperature is $25^\circ C$.
2. The test systems refer to Note 2.

Note 1: Definition of viewing angle

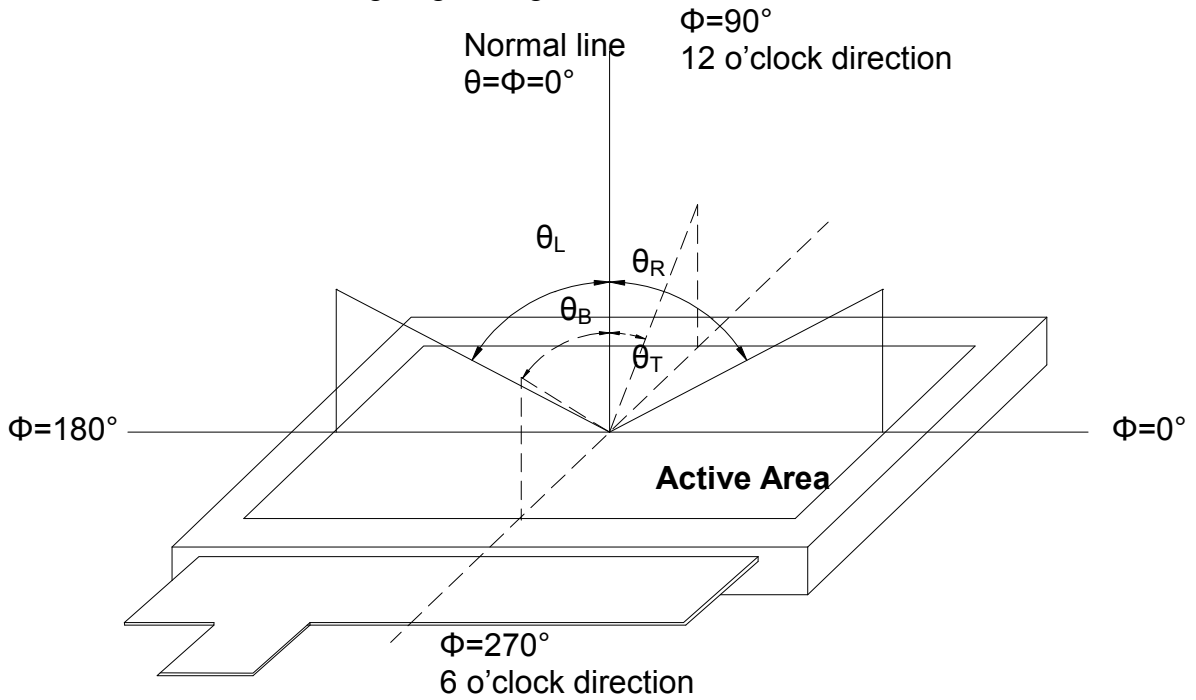

Fig. 4-1 Definition of viewing angle

Note 2: Definition of optical measurement system.

The optical characteristics should be measured in dark room. After 30 minutes operation, the optical properties are measured at the center point of the LCD screen. (Response time is measured by Photo detector TOPCON BM-7, other items are measured by BM-5A/Field of view: 1° /Height: 500mm.)

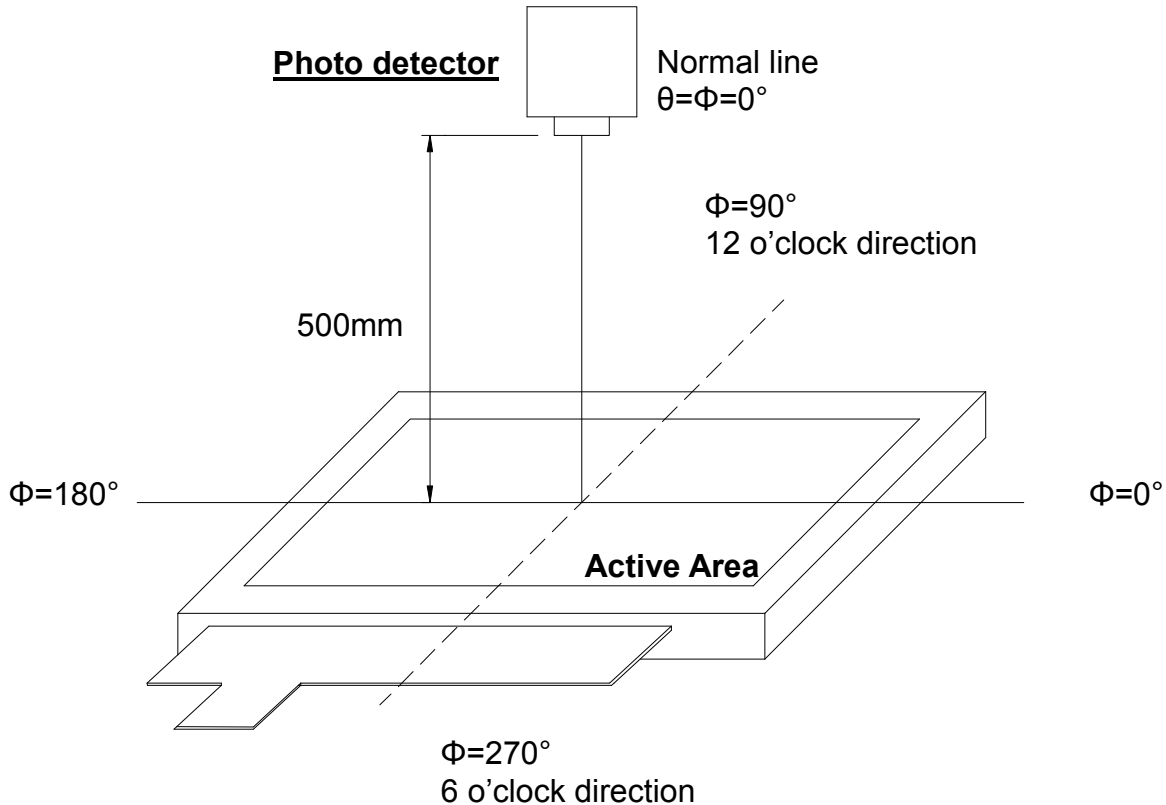

Fig. 4-2 Optical measurement system setup

Note 3: Definition of Response time

The response time is defined as the LCD optical switching time interval between "White" state and "Black" state. Rise time (T_{ON}) is the time between photo detector output intensity changed from 90% to 10%. And fall time (T_{OFF}) is the time between photo detector output intensity changed from 10% to 90%.

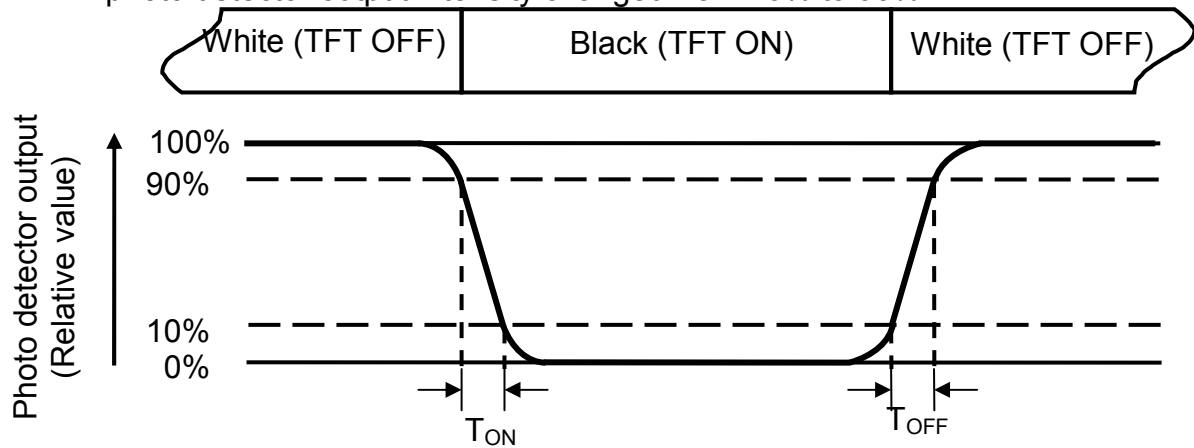

Fig. 4-3 Definition of response time

Note 4: Definition of contrast ratio

$$\text{Contrast ratio (CR)} = \frac{\text{Luminance measured when LCD on the "White" state}}{\text{Luminance measured when LCD on the "Black" state}}$$

Note 5: Definition of color chromaticity (CIE1931)

Color coordinates measured at center point of LCD.

Note 6: All input terminals LCD panel must be ground while measuring the center area of the panel.

Note 7: Definition of Luminance Uniformity

Active area is divided into 9 measuring areas (Refer to Fig. 4-4).Every measuring point is placed at the center of each measuring area.

$$\text{Luminance Uniformity (Yu)} = \frac{B_{min}}{B_{max}}$$

L-----Active area length W----- Active area width

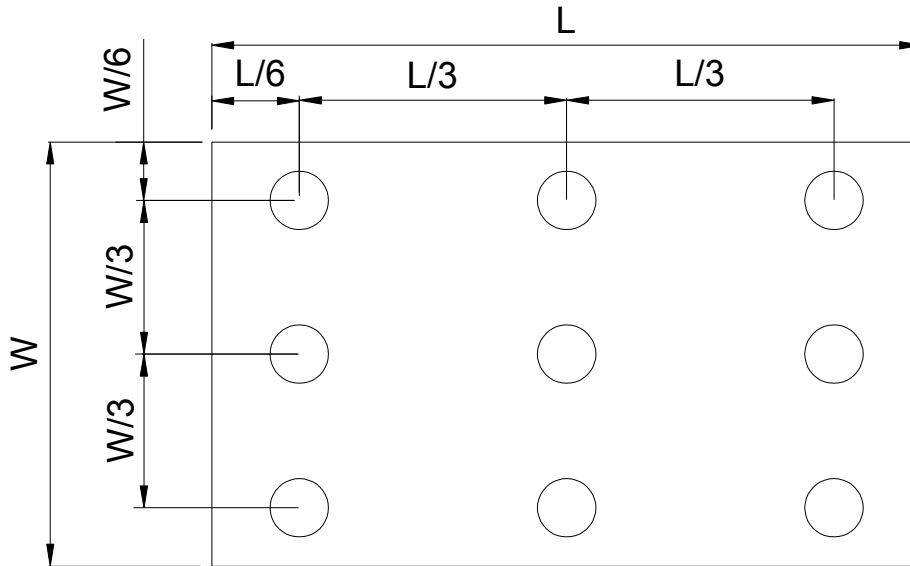

Fig. 4-4 Definition of measuring points

B_{max}: The measured maximum luminance of all measurement position.
B_{min}: The measured minimum luminance of all measurement position.

6. Reliability Test Items

(Note3)

Item	Test Conditions	Remark
High Temperature Storage	Ta = (80°C) 240 hrs	Note 1
Low Temperature Storage	Ta = (-30°C) 240hrs	Note 1
High Temperature Operation	Ts = (70°C) 240hrs	Note 2
Low Temperature Operation	Ta = (-20°C) 240hrs	Note 1
Operate at High Temperature and Humidity	+40°C, 90%RH 240 hrs	
Thermal Shock	-30°C/30 min ~ +80°C/30 min for a total 100 cycles, Start with cold temperature and end with high temperature	
Vibration Test	Frequency range:10~55Hz Stroke:1.5mm Sweep:10Hz~55Hz~10Hz 2 hours for each direction of X. Y. Z. (6 hours for total)	
Mechanical Shock	100G 6ms,±X, ±Y, ±Z 3 times for each direction	
Package Vibration Test	Random Vibration : 0.015G*G/Hz from 5-200HZ, -6dB/Octave from 200-500HZ 2 hours for each direction of X. Y. Z. (6 hours for total)	
Package Drop Test	Height:60 cm 1 corner, 3 edges, 6 surfaces	
Electro Static Discharge	± 2KV, Human Body Mode, 100pF/1500Ω	

Note 1: Ta is the ambient temperature of samples.

Note 2: Ts is the temperature of panel's surface.

Note 3: In the standard condition, there shall be no practical problem that may affect the display function.

7. General Precautions

7.1. Safety

Liquid crystal is poisonous. Do not put it in your mouth. If liquid crystal touches your skin or clothes, wash it off immediately by using soap and water.

7.2. Handling

1. The LCD panel is plate glass. Do not subject the panel to mechanical shock or to excessive force on its surface.
2. The polarizer attached to the display is easily damaged. Please handle it carefully to avoid scratch or other damages.
3. To avoid contamination on the display surface, do not touch the module surface with bare hands.
4. Keep a space so that the LCD panels do not touch other components.
5. Put cover board such as acrylic board on the surface of LCD panel to protect panel from damages.
6. Transparent electrodes may be disconnected if you use the LCD panel under environmental conditions where the condensation of dew occurs.
7. Do not leave module in direct sunlight to avoid malfunction of the ICs.

7.3. Static Electricity

1. Be sure to ground module before turning on power or operating module.
2. Do not apply voltage which exceeds the absolute maximum rating value.

7.4. Storage

1. Store the module in a dark room where must keep at $25\pm 10^{\circ}\text{C}$ and 65%RH or less.
2. Do not store the module in surroundings containing organic solvent or corrosive gas.
3. Store the module in an anti-electrostatic container or bag.

7.5. Cleaning

1. Do not wipe the polarizer with dry cloth. It might cause scratch.
2. Only use a soft sloth with IPA to wipe the polarizer, other chemicals might permanent damage to the polarizer.

8. Mechanical Drawing

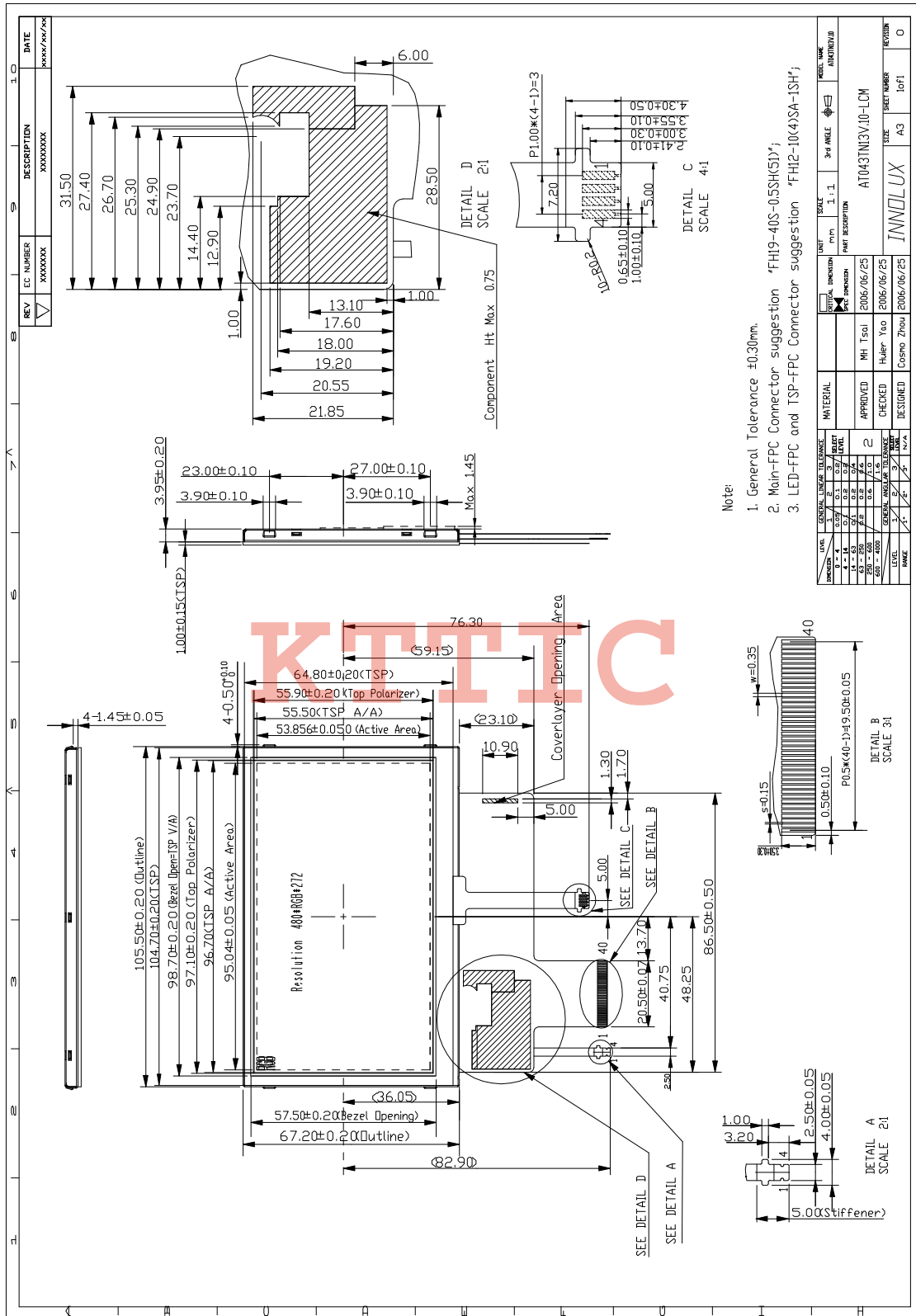

9. Package Drawing

TBD

KTTIC

KTTIC <http://www.kttic.com>

KTTIC

<http://www.kttic.com>