

**INNOLUX DISPLAY CORPORATION**

LCD MODULE

**SPECIFICATION**

Customer: \_\_\_\_\_

Model Name: AT035TN01

SPEC NO: AT035-01-TT-01

Date: December.29, 2003

Version: 1.0

Preliminary Specification

Final Specification

For Customer's Acceptance

Approved by	Comment

Approved by	Reviewed by	Prepare by

Revisions Section

Revision	Description	Date
1	Initial Release	2003/12/29

KTTIC

<b>Contents:</b>	<b>Page</b>
<b>1. General specification.....</b>	<b>2</b>
<b>2. Electrical specifications.....</b>	<b>2</b>
(1). Absolute maximum ratings	
(2). Pin assignment	
(a). TFT LCD panel driving section	
(3). Electrical characteristics	
(a). Typical operating conditions	
(b). Current consumption	
(c). Backlight driving conditions	
(4). AC timing	
(a). Timing conditions	
(b). Timing diagram	
<b>3. Optical specifications.....</b>	<b>11</b>
<b>4. Reliability test Items.....</b>	<b>13</b>
<b>5. Mechanical dimensions.....</b>	<b>14</b>
<b>6. Packing specifications.....</b>	<b>15</b>

KTTIC

### 1. General specifications

NO.	Item	Specification	Remark
1	LCD size	3.5 inch	
2	Driver Element	a-Si TFT active matrix	
3	Display contents(dot)	480(W)X 234 (H)	
4	Display Mode	Normally white, Transmissive with Backlight	
5	Dot pitch	0.15(W) X 0.216(H) mm	
6	Active area	72(W) X 50.544(H) mm	
7	Module Size	83±0.3(W)x60.5±0.3(H)x4.5±0.3 (D)mm	
8	Color configuration	R.G.B delta	
9	Weight	34.5 g Typical	

### 2. Electrical specifications

#### (1). Absolute maximum ratings

Item	Symbol	Condition	Values		Unit	Remark
			Min.	Max.		
Power voltage	$DV_{DD}, V_{CC}$	GND=0	-0.3	7	V	
	$AV_{DD}$	$AV_{SS}=0$	-0.3	7	V	
	$V_{GH}$	GND=0	-0.3	18	V	
	$V_{GL}$		-18	0.3	V	
	$V_{GH} - V_{GL}$	-	-	33	V	
Input signal voltage	$V_i$	-	-0.3	$AV_{DD}+0.3$	V	Note 1
	$V_I$	-	-0.3	$DV_{DD}+0.3$	V	Note 2
	VCOM	-	-2.9	5.2	V	
Operation Temperature	Top	-	0	60	°C	Ambient
Storage Temperature	Tst	-	-25	80	°C	Ambient

Note :

1. VR, VG, VB.
2. STHL, STHR, OEH, L/R, CPH1~CPH3, STVR, STVL, OEV, CKV, U/D, Q1H

**(2). Pin assignment**

(a). TFT LCD panel diving section

Pin no	Symbol	IO	Function	Remark
1	GND	P	Ground for logic circuit	
2	DV <sub>DD</sub>	P	Supply voltage of logic control circuit for driver	
3	V <sub>GL</sub>	P	Negative power for scan driver	
4	V <sub>GH</sub>	P	Positive power for scan driver	
5	STVR	I/O	Vertical start pulse	Note 1
6	STVL	I/O	Vertical start pulse	Note 1
7	CKV	I	Shift clock input for scan driver	
8	U/D	I	UP/DOWN scan control input	Note 1,2
9	OEV	I	Output enable control for scan driver	
10	VCOM	I	Common electrode driving signal	
11	VCOM	I	Common electrode driving signal	
12	GLED1	P	LED module 1 Cathode	
13	VLED1	P	LED module 1 Anode	
14	VLED2	P	LED module 2 Cathode	
15	GLED2	P	LED module 2 Anode	
16	L/R	I	LEFT/RIGHT scan control	Note 1,2
17	Q1H	I	Analog signal rotate input	
18	OEH	I	Output enable control for data driver	
19	STHL	I/O	Start pulse for horizontal scan line	Note 1
20	STHR	I/O	Start pulse for horizontal scan line	Note 1
21	CPH3	I	Sampling and shifting clock pulse for data driver	
22	CPH2	I	Sampling and shifting clock pulse for data driver	
23	CPH1	I	Sampling and shifting clock pulse for data driver	
24	DV <sub>DD</sub>	P	Supply voltage of logic control circuit for driver	
25	GND	P	Ground for logic circuit	
26	VR	I	Alternated video signal (Red)	
27	VG	I	Alternated video signal (Green)	
28	VB	I	Alternated video signal (Blue)	
29	AV <sub>DD</sub>	P	Supply voltage for analog circuit	
30	AV <sub>SS</sub>	P	Ground for analog circuit	

Note:

1. Selection of scanning mode (please refer to the following table),if  $DV_{DD}=V_{CC}$

Setting of scan control input		IN/OUT state for start pulse				Scanning direction
U/D	L/R	STVR	STVL	STHR	STHL	
GND	$V_{CC}$	O	I	O	I	Up to down, left to right
$V_{CC}$	GND	I	O	I	O	Down to up, right to left
GND	GND	O	I	I	O	Up to down, right to left
$V_{CC}$	$V_{CC}$	I	O	O	I	Down to up, left to right

I: input, O: output

2. Definition of Scanning Direction.

Refer to figure as below:

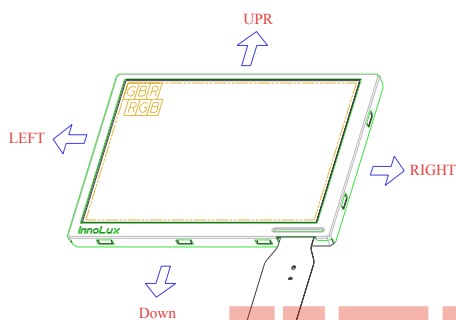

KTTIC

**(3). Electrical characteristics**

(a). Typical operating conditions ( $GND=AV_{SS}=0V$ , Note 4)

Item	Symbol	Values			Unit	Remark
		Min.	Typ.	Max.		
Power supply	$DV_{DD}, V_{CC}$	3	5	5.2	V	
	$AV_{DD}$	4.8	5	5.2	V	
	$V_{GH}$	14.3	15	15.7	V	
	$V_{GLAC}$	3.5	5	7.5	V	AC component of $V_{GL}$ Note 1
	$V_{GL-H}$	-10	-9.5	-9	V	High level of $V_{GL}$
Video signal amplitude (VR, VG, VB)	$V_{iAm}$	0.4	-	$AV_{DD}-0.4$	V	Note2
	$V_{iAC}$	-	3	-	V	AC component
	$V_{iDC}$	-	$AV_{DD}/2$	-	V	DC component
VCOM	$V_{CAC}$	3.5	5	6.5	V	Note3
	$V_{CDC}$	1.0	1.25	1.5	V	DC component
Input signal Voltage	H level	$V_{IH}$	$0.8V_{CC}$	-	$V_{CC}$	Note4 $DV_{DD}=V_{CC}$
	L level	$V_{IL}$	0	-	$0.2V_{CC}$	

Note:

1. The same phase and amplitude with common electrode driving signal (VCOM)
2. Refer to Fig.3-(a).
3. The brightness of LCD panel could be changed by adjusting the AC component of VCOM.
4. SRHL, STHR, OEH, L/R, CPH1~CPH3, STVR, STVL, OEV, CKV, U/D, Q1H
5. Be sure to apply GND, V<sub>CC</sub>, and V<sub>GL</sub>, to the LCD first, and then apply V<sub>GH</sub>

(b). Current consumption (GND=AV<sub>SS</sub>=0V)

Parameter	Symbol	Condition	Values			Unit	Remark
			Min.	Typ.	Max.		
Current for Driver	I <sub>GH</sub>	V <sub>GH</sub> =15V	-	100	300	uA	V <sub>GH</sub>
	I <sub>GL</sub>	V <sub>GL-H</sub> =-9.5V	-	-100	-300	uA	V <sub>GL</sub>
	I <sub>DD</sub>	DV <sub>DD</sub> =5V	-	1.5	4	mA	DV <sub>DD</sub>
	I <sub>AVDD</sub>	AV <sub>DD</sub> =5V	-	5	10	mA	AV <sub>DD</sub>

(c). LED driving conditions

Item	Symbol	Values			Unit	Remark
		Min.	Typ.	Max.		
LED voltage	V <sub>L</sub>	-	15	-	V	Note 2
LED Current	I <sub>L</sub>	-	20	-	mA	Note 2
LED life time	-	(10,000)	-	-	Hr	Note 1

Note :

1. The "LED life time" is defined as the module brightness decrease to 50% original brightness at Ta=25°C, I<sub>L</sub>=20mA
2. The LED driving condition is defined for each LED module (4 LEDs Serial).

#### (4). AC timing

(a). Timing conditions (sequential mode)

Item	Symbol	Values			Unit	Remark
		Min.	Typ.	Max.		
Rising time	t <sub>r</sub>	-	-	100	ns	Note 1
Falling time	t <sub>f</sub>	-	-	100	ns	Note 1
High and low level pulse width	t <sub>CPH</sub>	299	312	342	ns	CPH1~CPH3
CPH pulse duty	t <sub>CWH</sub>	40	50	60	%	CPH1~CPH3
CPH pulse delay	t <sub>C12</sub> t <sub>C23</sub> t <sub>C31</sub>	70	t <sub>CPH</sub> /3	t <sub>CPH</sub> /2	ns	CPH1~CPH3
STH setup time	t <sub>SUH</sub>	35	-	-	ns	STHR, STHL
STH hold time	t <sub>HDH</sub>	35	-	-	ns	STHR, STHL
STH pulse width	t <sub>STH</sub>	-	1	-	t <sub>CPH</sub>	STHR, STHL
STH period	t <sub>H</sub>	61.5	63.5	65.5	μs	STHR, STHL
OEH pulse width	t <sub>OEH</sub>	-	3	-	t <sub>CPH</sub>	

Sample and hold disable time	$t_{DIS1}$	-	8.42	--	$\mu s$	
OEV pulse width	$t_{OEV}$	-	13		$t_{CPH}$	
CKV pulse width	$t_{CKV}$	16	20	40	$t_{CPH}$	
Clean enable time	$t_{DIS2}$	-	10	--	$t_{CPH}$	
Horizontal display start	$t_{SH}$	-	0	-	$t_{CPH}/3$	
Horizontal display timing range	$t_{DH}$	-	480	-	$t_{CPH}/3$	
STV setup time	$t_{SUV}$	400	-	-	Ns	STVL, STVR
STV hold time	$t_{HDV}$	400	-	-	Ns	STVL, STVR
STV pulse width	$t_{STV}$	-	-	1	$t_H$	STVL, STVR
Horizontal lines per field	$t_V$	256	262	268	$t_H$	Note 2
Vertical display start	$t_{SV}$		3	-	$t_H$	
Vertical display timing range	$t_{DV}$		234	-	$t_H$	
VCOM rising time	$t_{rCOM}$		-	5	$\mu s$	
VCOM falling time	$t_{fCOM}$		-	5	$\mu s$	
VCOM delay time	$t_{DCOM}$		-	3	$\mu s$	
RGB delay time	$t_{DRGB}$		-	1	$\mu s$	

Note :

1. For all of the logic signals
2. Please don't use odd horizontal lines to drive LCD panel for both odd and even field simultaneously.



(b). Timing diagram

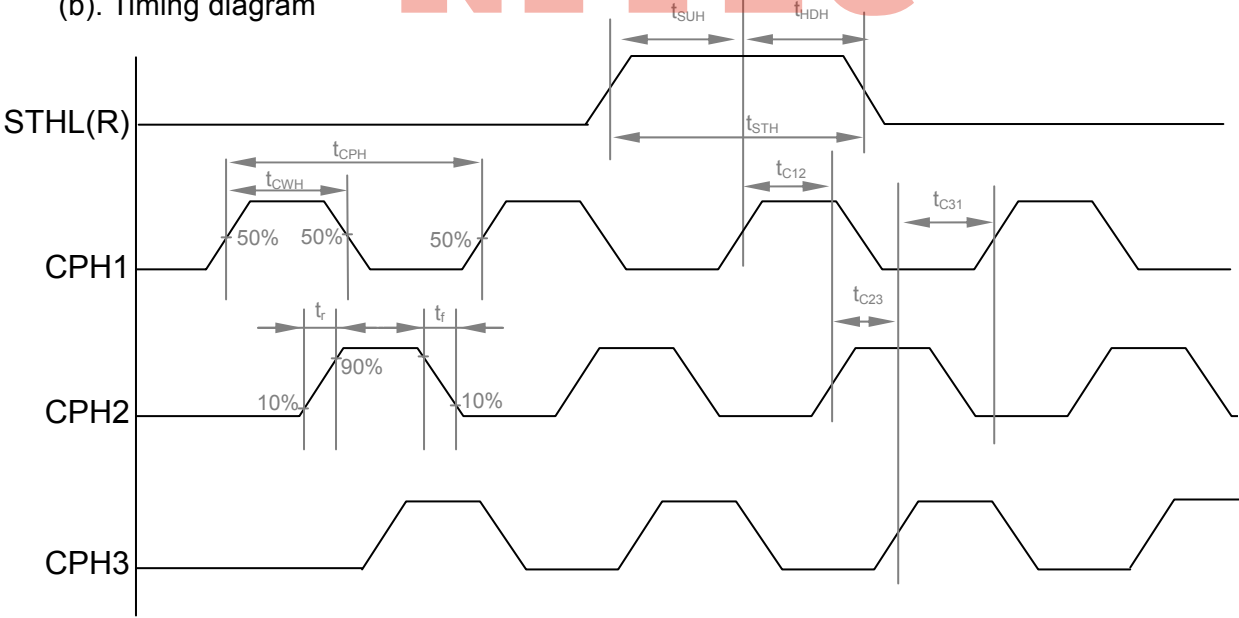

Fig.1 Sampling clock timing



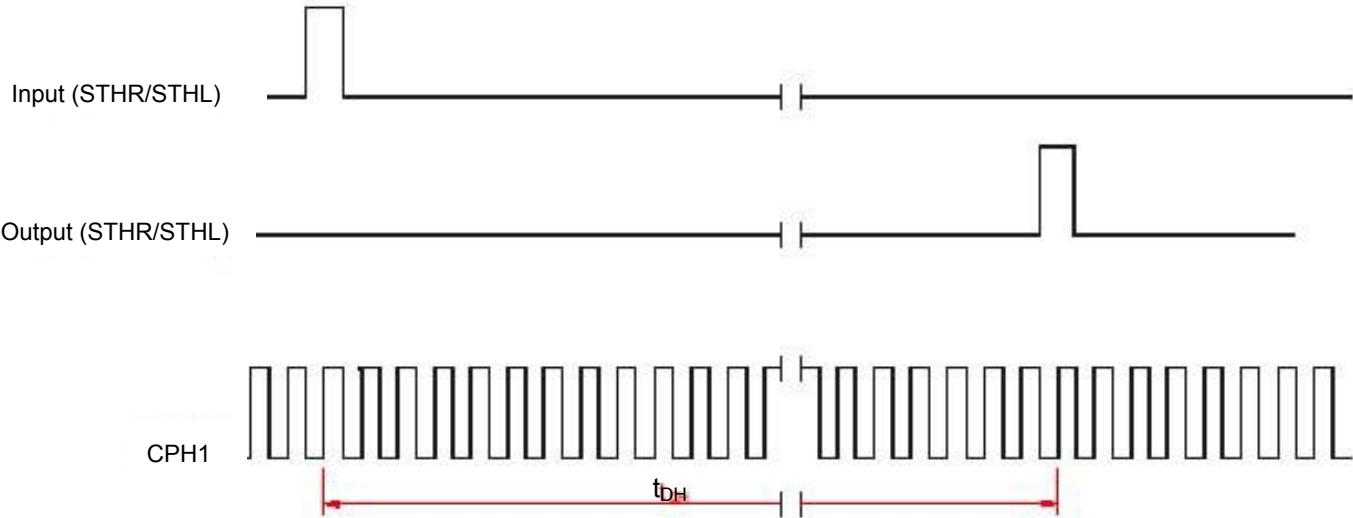

Fig.2 Horizontal display timing range

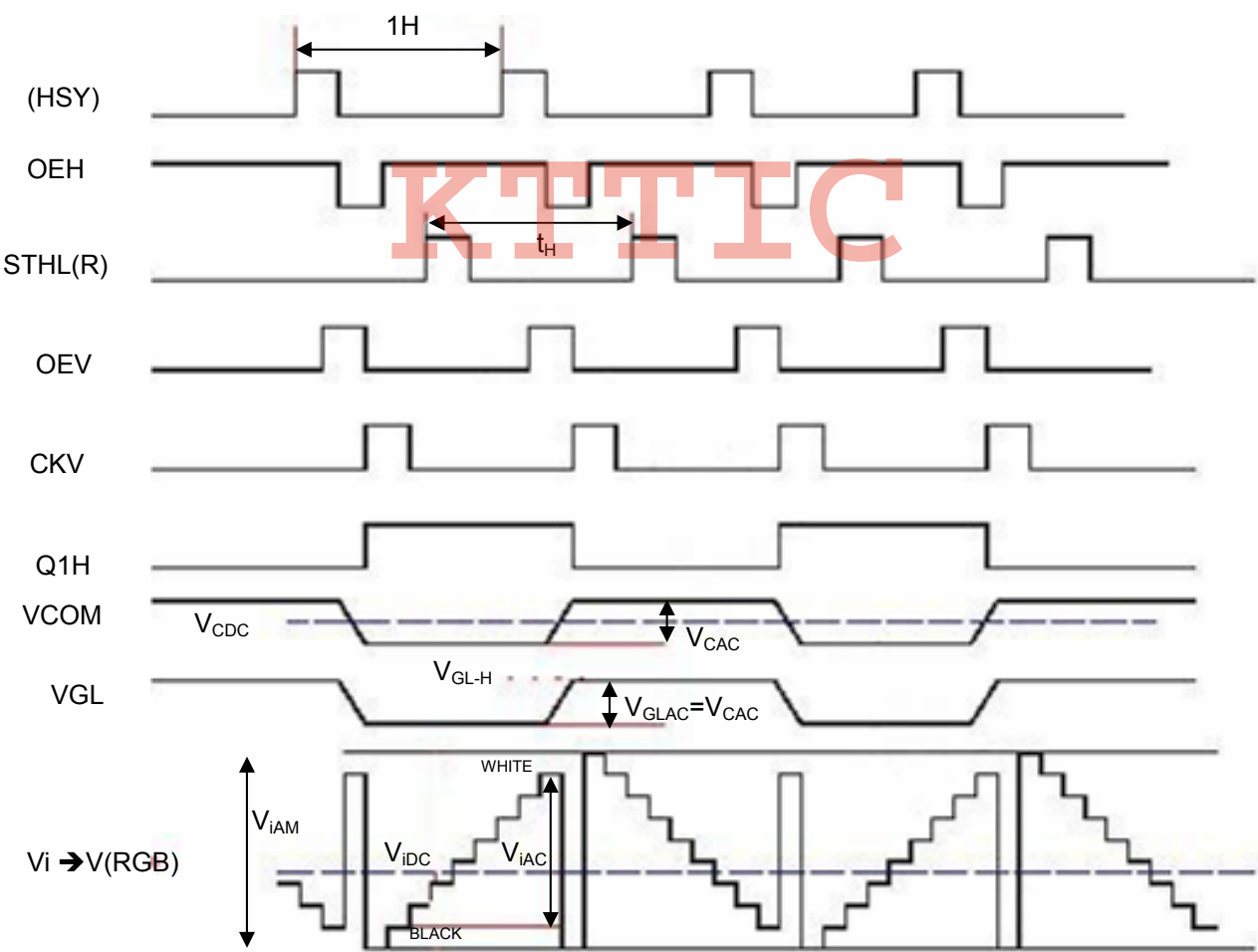
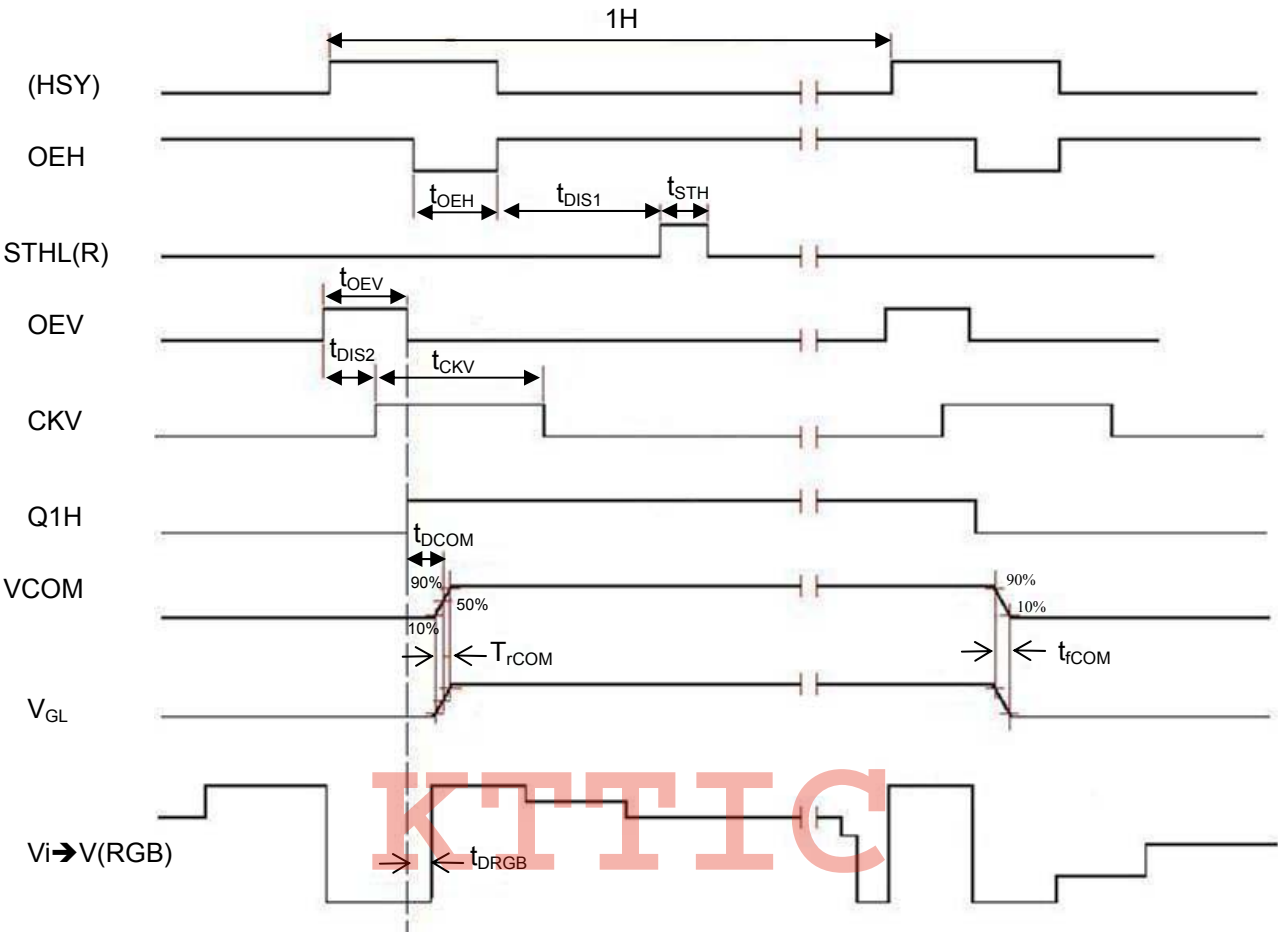

Fig.3-(a) Horizontal timing



Note: The falling edge of OEV should be synchronized with the falling edge of OEH

Fig.3-(b) Detail horizontal timing

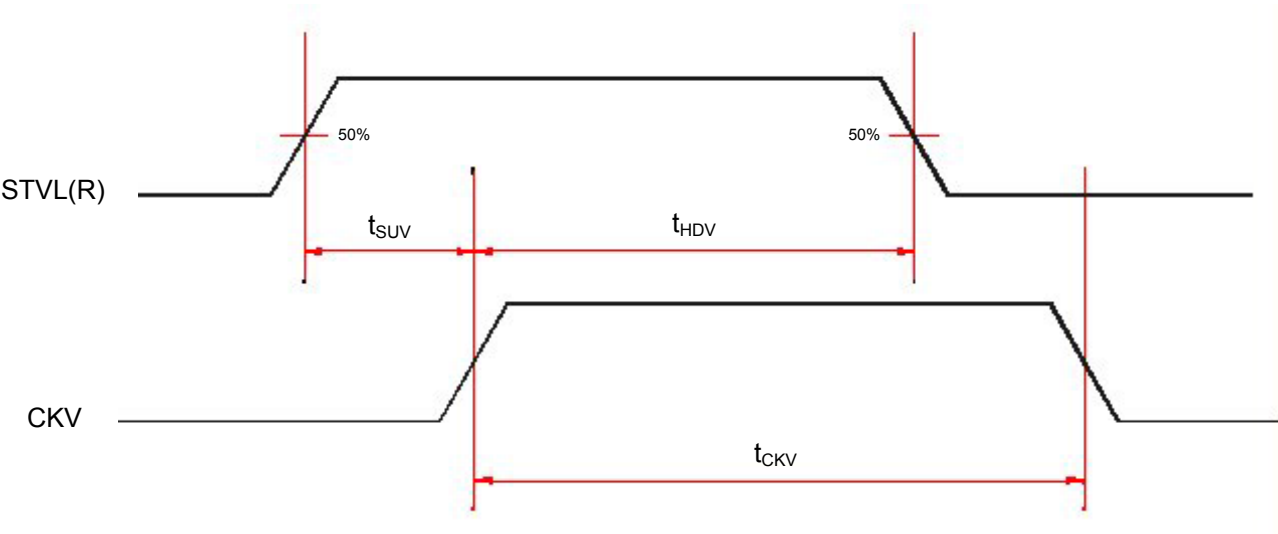

Fig.4 Vertical shift clock timing

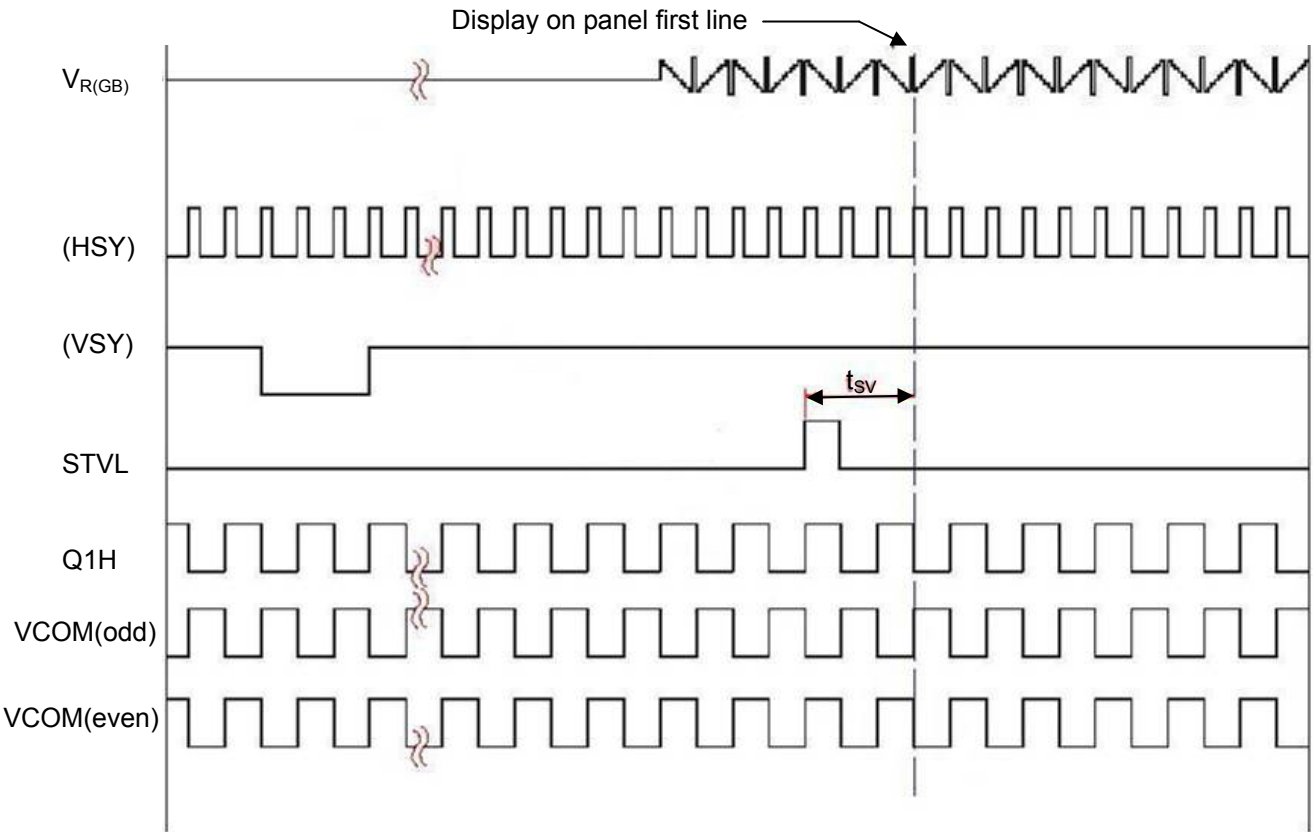

Fig.5-(a) Vertical timing (from up to down)

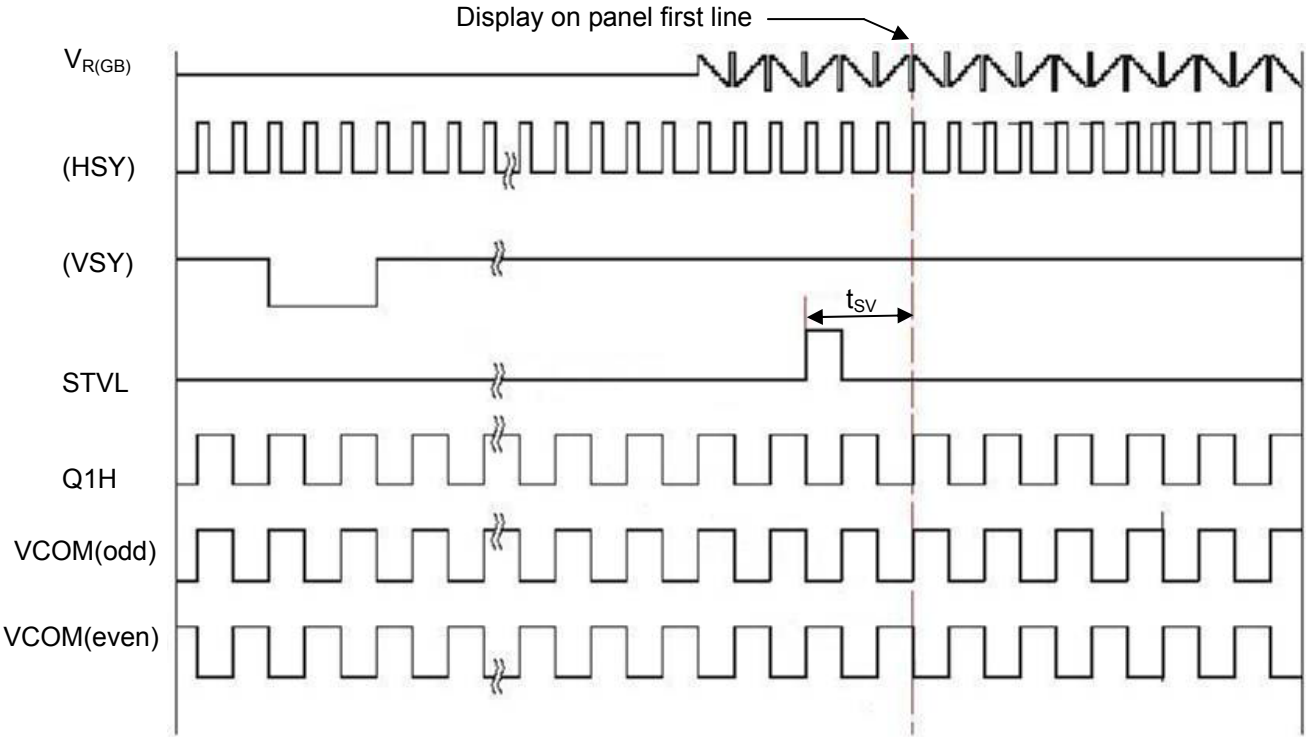
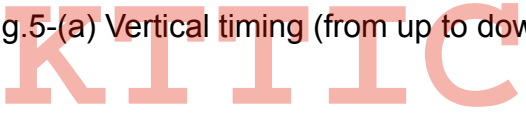
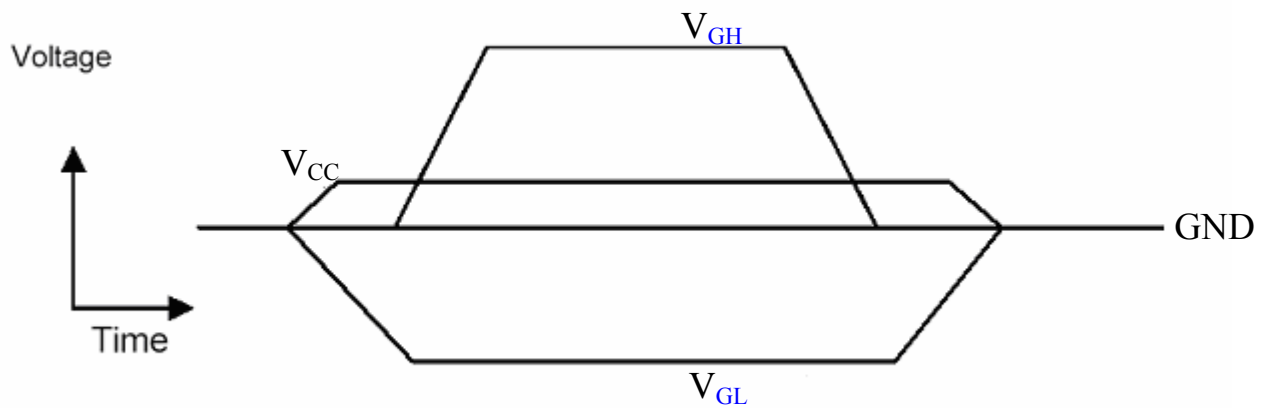

Fig.5-(b) Vertical timing (from down to up)

**(5)Power sequence**

This module adopts high voltage driver IC, so it may be damaged by a large current flow if a wrong power on/off sequence is used! The recommend power sequence is to connect  $V_{CC}$  first, then connect power to driver gate power,  $V_{GL}$  and  $V_{GH}$ . When shutting off the power, shut off the driver gate power,  $V_{GL}$  and  $V_{GH}$ , then shut off the logic power,  $V_{CC}$ , or shut off the power simultaneously!



# KTTIC

### 3. Optical specifications

The following items are measured under stable conditions. The optical characteristics should be measured in dark room or equivalent state with the methods shown in Note 1.

$T_a=25\pm 2^{\circ}\text{C}$ ,  $I_L=20\text{mA}$

Item	Symbol	Condition	Min	Typ	Max	Unit	Remark	
Response time	$T_R$	$\Theta=0$	-	20	30	ms	Note2	
	$T_F$		-	30	40	ms		
Contrast ratio	CR	At optimized viewing angle	150	200			Note3	
Brightness	$Y_L$	$\Theta=0$	200	250		$\text{Cd/m}^2$	Note4	
Color Chromaticity	White	$\Theta=0$	$W_x$	(0.26)	(0.31)	(0.36)		Note4
			$W_y$	(0.28)	(0.33)	(0.38)		
Viewing Angle	Hor.	CR $\geq 10$	$\Theta_R$	40	45		Degree	Note5
			$\Theta_L$	40	45			
	Ver.		$\Phi_H$	10	15			
			$\Phi_L$	30	35			

Note:

1. Test equipment setup

After stabilizing and leaving the panel alone at a given temperature for 30 minutes, the measurement should be executed. Measurement should be executed in a stable, windless, and dark room. Optical specifications are measured by Topcon BM-5A with a viewing angle of  $1^{\circ}$  at a distance of 50cm and normal direction.

2. Definition of response time:  $T_R$  and  $T_F$

The figure below is the output signal of the photo detector.

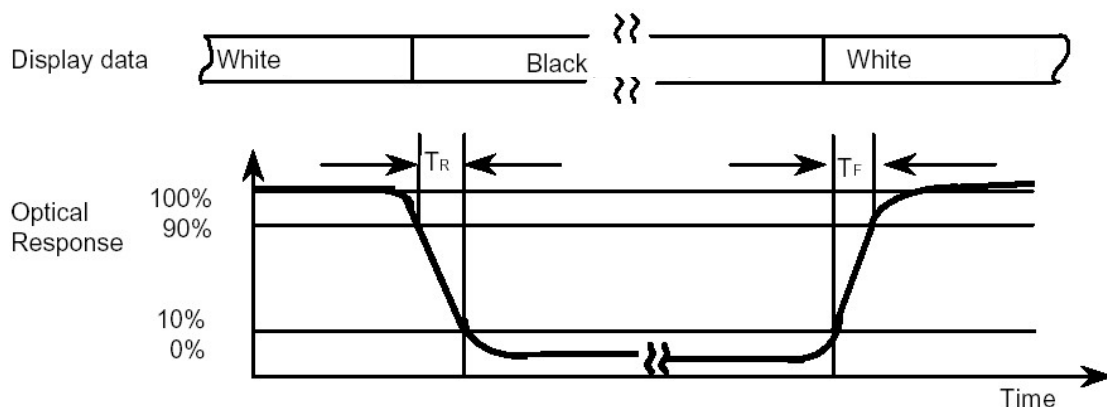

3. Definition of contrast ratio:

$$\text{Contrast ratio (CR)} = \frac{\text{Brightness measured when LCD is at "white" state}}{\text{Brightness measured when LCD is at "black" state}}$$

White  $V_i = V_{i50\%} \pm 1.5 \text{ V}$

Black  $V_i = V_{i50\%} \mp 2.0 \text{ V}$

"±" means that the analog input signal swings in phase with VCOM signal.

"∓" means that the analog input signal swings out of phase with VCOM signal.

$V_{i50\%}$  : The analog input voltage when transmission is 50%

4. The 100% transmission is defined as the transmission of LCD panel when all the input terminals of module are electrically opened.

5. Definition of viewing angle:

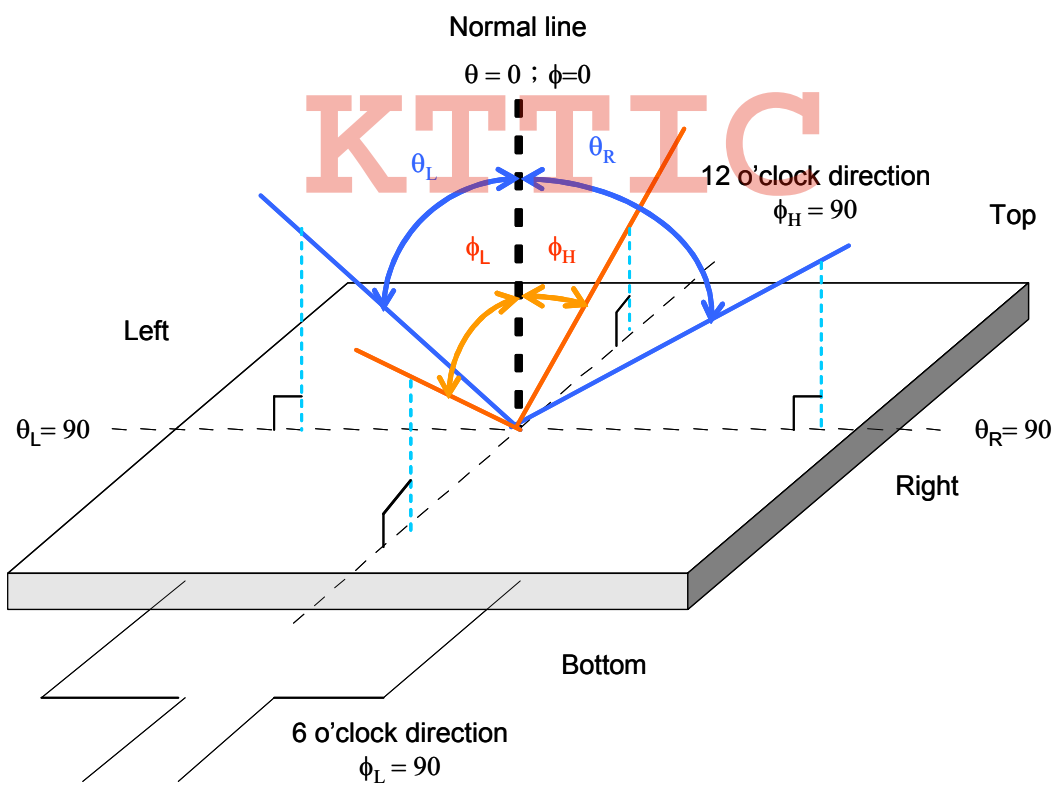

**4. Reliability test items**

(1). Reliability levels in mass production are as below:

Test Items	Test Conditions	
High temperature storage	+80°C±3°C, Dry(30%RH max.) for 240 hours	
Low temperature storage	-25°C±3°C for 240 hours	
High temperature operation	+60°C±3°C, Dry(30%RH max.) for 240 hours	
Low temperature operation	0°C±3°C for 240 hours	
Operation at high temperature and humidity	+60°C±3°C, 95%±3%RH max. for 240 hours	
Thermal shock	-25°C/1h ~ +85°C/1h for a total 50 cycles, Start with cold temp and end with high temp	
Vibration test	Frequency range:10~55Hz Stoke:1.5m Sweep:10Hz~55Hz~10Hz 2 hours for each direction of X. Y. Z. (6 hours for total)	JIS C7021 A-10 Condition A
Vibration Test (with carton)	Random Vibration : 0.015G*G/Hz from 5-200HZ, -6dB/Octave from 200-500HZ	IEC 68-34
Drop Test (with carton)	Height:60 cm 1 corner, 3 edges, 6 surfaces	JIS Z0202
Mechanical Shock	100G 6ms,±X, ±Y, ±Z 3 times for each direction	JIS C7021 A-7 Condition C

Note 1: High temp storage & High temp/High humidity Op the polarizer is out of subject

Note 2: the test sample has recovery time 2 hours at room temp before function check

(2). Criteria

- a. Function Characteristics: No abnormalities.
- b. Display Characteristics: Satisfy the original standard.  
(Uneven contrast, bubble, blur, etc.)
- c. Electrical Characteristics: Satisfy the original standard.
- d. Appearance: No relief, etc at joint.

(3). Electro Static Discharge

Parameter	Symbol	Values	unit	Remark
Electro-static discharge	V <sub>ESD</sub>	±2K	V	Human Body Mode, 100pF/1500Ω
		±200	V	Machine Mode 200pF/0Ω

5. Mechanical dimensions

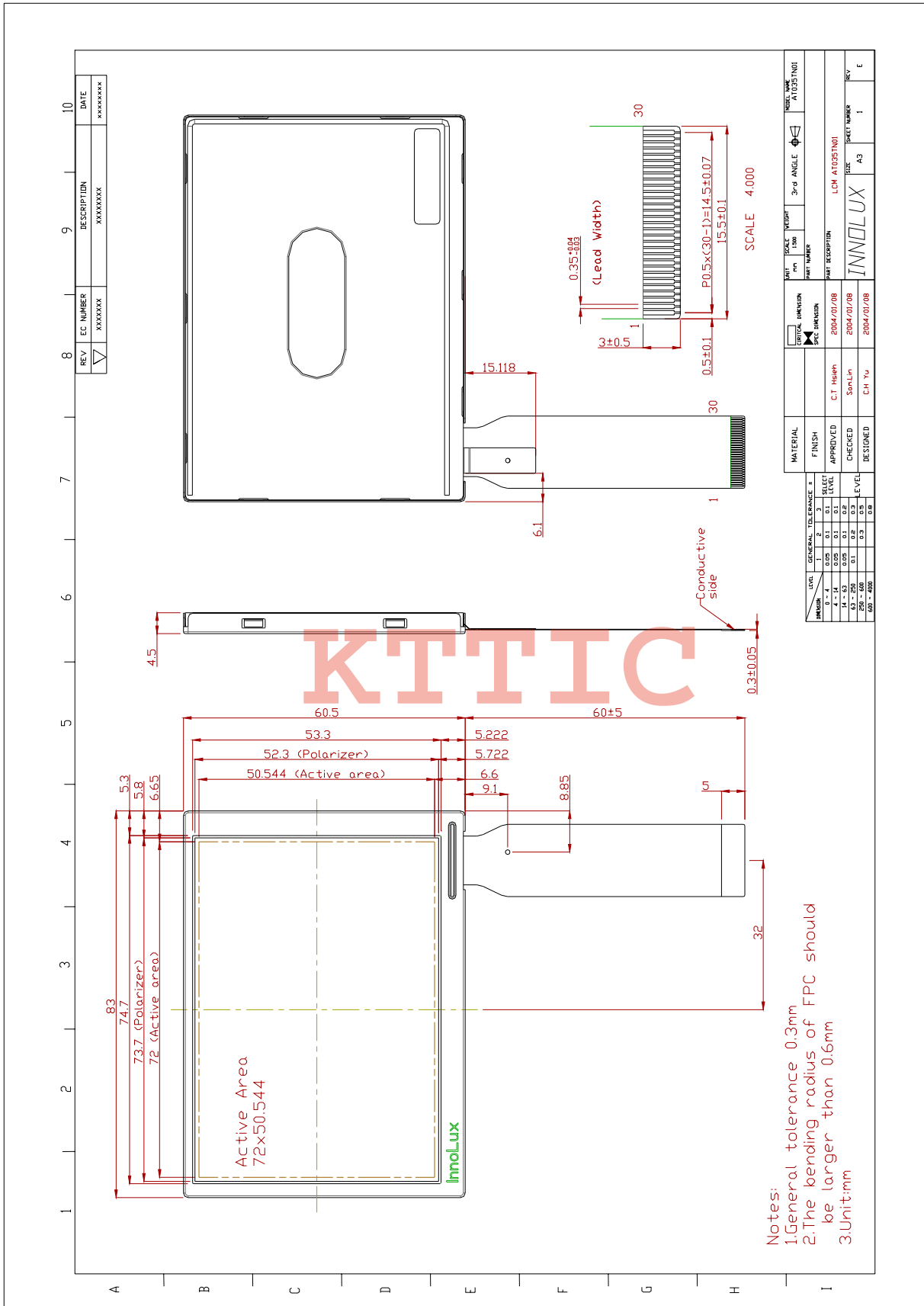



**6. Packing specifications**

(1). Packaging material table





Per carton

No	Item	Model (Material)	Dimensions(mm)	Unit Weight(Kg)	Quantity	Remark
1	LCM module	AT035TN01	83x60.5x4.5	0.0345	240	
2	EPP tray	EPP	516x384x6.5	0.142	3	Anti-static
3	Cover tray	EPE	493x326x10	0.024	1	Anti-static
4	Anti-Static Bag	PE	100x80x0.05	0.001	240	Anti-static
5	Carton	Carton	530x355x255	2.3	1	
5	Total weight	11.27 Kg ± 5%				

(2). Packaging quantity

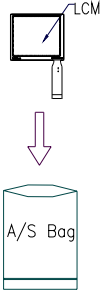
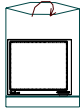
(1) LCM quantity per tray: no. of the row $2 \text{ row} \times 28 \text{ column} + 1 \text{ row} \times 24 \text{ column} = 80$
(2) Total LCM quantity in Carton: no. of EPP trays $3 \times \text{quantity per tray } 80 = 240$

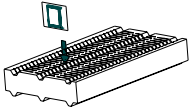
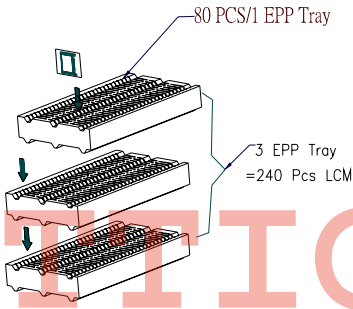
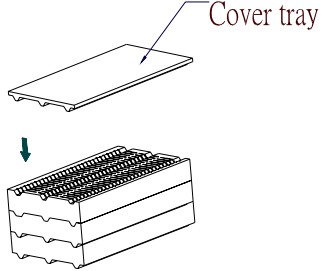
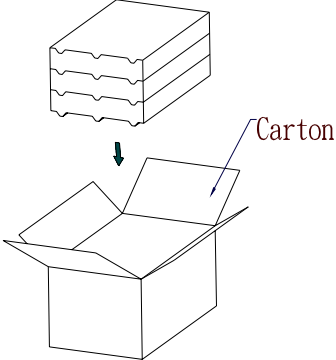
(3).Packing Drawing

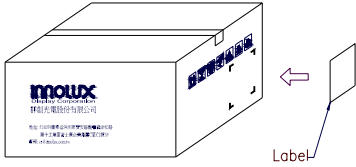
<p>Step A.</p>  <p>Put LCM in the A/S bag</p>	<p>Step B.</p>  <p>Turn the upwards A/S bag back</p>	<p>Step C.</p>  <p>Seal the A/S bag</p>
<p>Step D.</p>  <p>Put LCM in the EPP tray 100pcs per EPP tray</p>	<p>Step E.</p>  <p>Stack 3 EPP trays Total numbers :240pcs</p>	<p>Step F.</p>  <p>Put 1 cover tray on the top of every 3 stacked trays</p>
<p>Step G.</p>  <p>Put stacked trays in outer carton</p>	<p>Step H.</p>  <p>Seal outer carton</p>	<p>Step I.</p>  <p>Paste the label on outer carton</p>

KTTIC <http://www.kttic.com>

KTTIC

<http://www.kttic.com>