

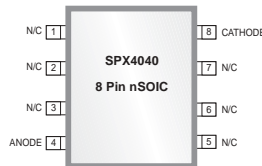

Precision Micropower 2.5V Shunt Voltage Reference

FEATURES

- Trimmed Bandgap to 0.5% and 1%
- Wide Operating Current 160µA to 15mA
- Extended Temperature Range: -40°C to 85°C
- Low Temperature Coefficient 100 ppm/°C
- Replacement in for LM4040



Now Available in Lead Free Packaging

APPLICATIONS

- Battery Operating Equipment
- Adjustable Supplies
- Switching Power Supplies
- Error Amplifiers
- Single Supply Amplifier
- Monitors / VCRs / TVs
- Personal Computers

DESCRIPTION

The SPX4040 is a 2-terminal, temperature compensated, bandgap voltage reference that provides a fixed 2.5V output for input currents between 160µA and 15mA. The bandgap voltage (2.5V) is independently trimmed from the output voltage to achieve a very low temperature coefficient. This trimming technique gives a stable device over the full temperature range (100ppm/°C).

The SPX4040 is available in 3 pin TO-92, 3 SOT-23 and 8 pin NSOIC packages. The operating temperature range is -40°C to 85°C. The SPX4040 advanced design eliminates the need for an external stabilizing capacitor while ensuring stability with any capacitive load, making it easy to use.

TYPICAL APPLICATIONS CIRCUIT

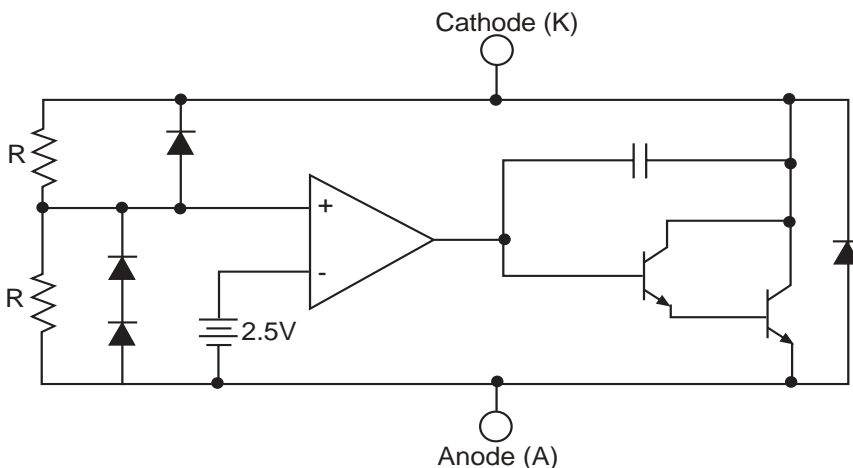

ABSOLUTE MAXIMUM RATINGS

Anode-Cathode Forward Current, (I_{AK}) 10mA
 Anode-Cathode Reverse Current I_{KA} 20mA
 Continuous Power Dissipation at 25°C P_D
 TO-92 550mW
 SOT-23 300 mW
 SOIC-8 525mW
 Junction Temperature T_J 150 °C
 Storage Temperature T_{STG} -65 to 150 °C

TYPICAL THERMAL RESISTANCES

PACKAGE	θ_{JA}	θ_{JC}	TYPICAL DERATING
TO-92	160°C/W	80°C/W	6.3 mW/°C
SOT-23	575°C/W	150°C/W	1.7 mW/°C
SOIC-8	175°C/W	45°C/W	5.7 mW/°C

Typical deratings of the thermal resistances are given for ambient temperature >25°C.

NOTE: Stresses greater than those listed under ABSOLUTE MAXIMUM RATINGS may cause permanent damage to the device. This is a stress rating only and functional operation of the device at these or any other conditions above those indicated in the operational sections of this specification is not implied. Exposure to absolute maximum rating conditions for extended periods may affect reliability.

ELECTRICAL CHARACTERISTICS

Electrical characteristics at $I_N = 1000\mu A$ and $T_A = +25^\circ C$ unless otherwise specified.

PARAMETERS	CONDITIONS	SPX4040A-2.5			SPX4040-2.5			UNITS
		MIN	TYP	MAX	MIN	TYP	MAX	
Reverse Breakdown Voltage	$I_R = 500 \mu A$	2.4875	2.500	2.5125	2.475	2.500	2.525	V
Reverse Breakdown Tolerance	$I_R = 500\mu A$ $-40^\circ C < T_A < 85^\circ C$			± 12 ± 29			± 25 ± 49	mV mV
Output Impedance			0.60	0.8		0.60	0.8	Ω
Noise Voltage	$0.1KHz \leq f \leq 10Hz$		15			15		μV p-p
Tempco	Note 1			100			100	ppm/°C
Turn-on Setting	1.0% of V_{OUT}		30			30		μSec
Operating Current Range	Note 2	0.16		15	0.16		15	mA
Temp. Range (ambient)		-40		85	-40		85	°C

Notes:

1. Three-point measurement guarantees the error band over the specified temperature range.
2. Optimum performance is obtained at current below 1000 μA .

CALCULATING AVERAGE TEMPERATURE COEFFICIENT (TC)

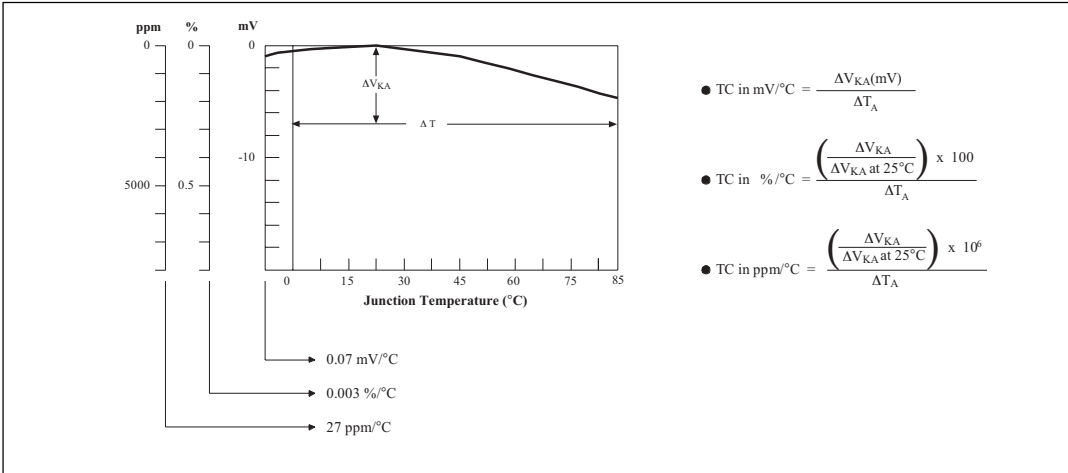

Figure 1. V_{KA} VS Temperature.

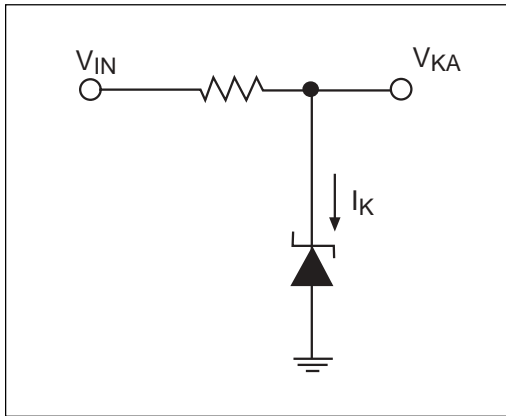

Figure 2. Test Circuit for $I_{K REVERSE}$, $V_{KA} = 2.5V$

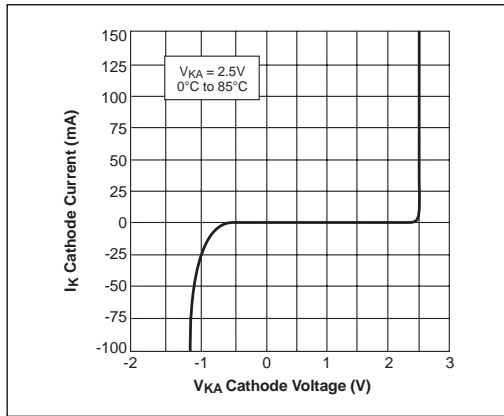

Figure 3. High Current Operating Characteristics

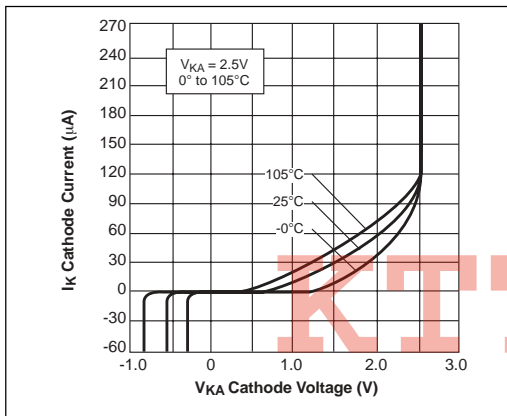

Figure 4. Low Current Operating Characteristics

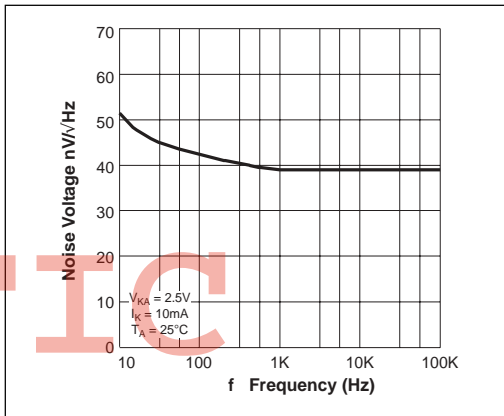

Figure 5. Noise Voltage VS Frequency

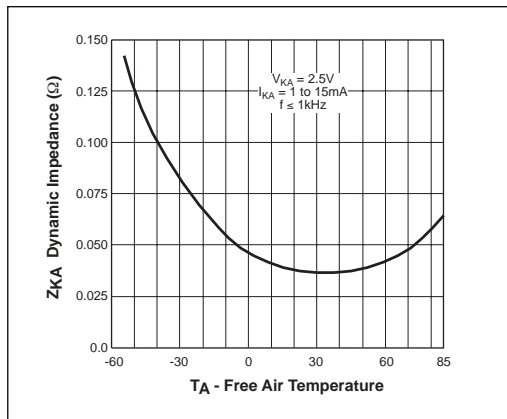

Figure 6. Low Frequency Dynamic Output Impedance VS. $T_{AMBIENT}$

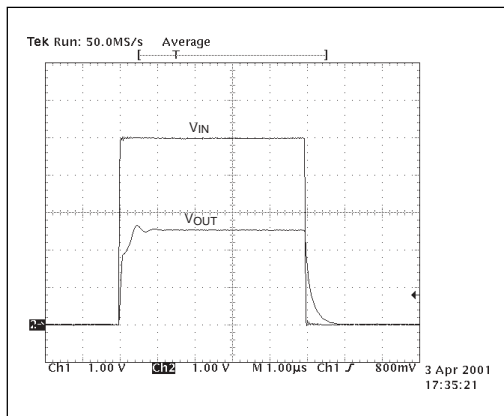

Figure 7. Frequency = 100kHz, $I_K = 10mA$, $T_A = 25°C$

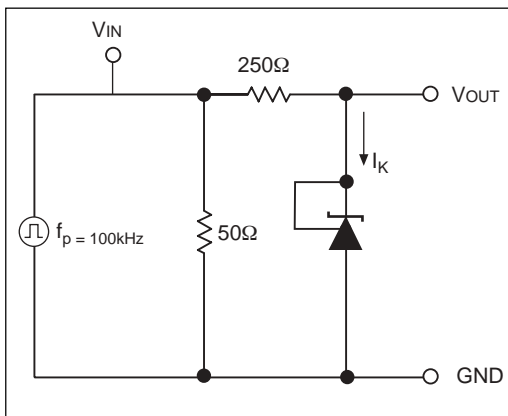

Figure 8. Test Circuit for Pulse Response

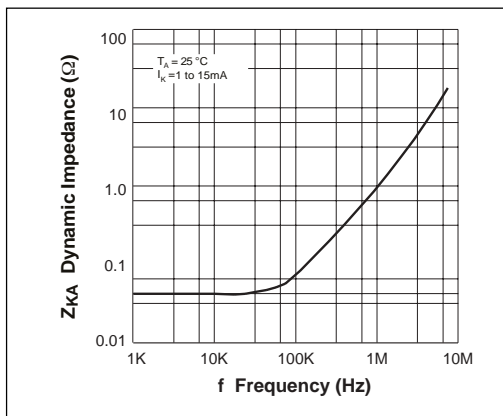

Figure 9. Dynamic Output Impedance $T_A = 25^\circ\text{C}$, $I_K = 1$ to 15mA

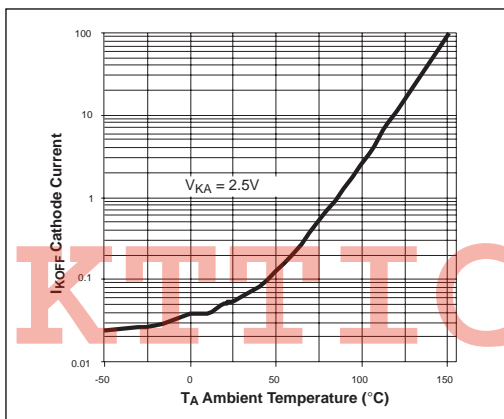

Figure 10. Off State Leakage

APPLICATION INFORMATION

This device is designed for stable operation and has no need of an external capacitor between pins 4 and 8. The reference remains stable if a bypass capacitor is used.

SOT-23

The SPX4040 in the SOT-23 package has a parasitic Schottky diode between pin 3 and pin 1. Pin 1 of SOT-23 must float or be connected to pin 3.

Conventional Shunt Regulator

In a conventional shunt regulator application (see Figure 11), an external series resistor (R_S) is connected between the supply voltage and the

SPX4040. R_S determines the current that flows through the load (I_L) and the reference (I_Q). Since load current and supply voltage may vary, R_S should be small enough to supply at least the minimum acceptable I_Q to the reference even when the supply voltage is at its minimum and the load current is at its maximum value. When the supply voltage is at its maximum and I_L is at its minimum, R_S should be large enough so that the current flowing through the SPX4040 is less than 15mA.

R_S is determined by the supply voltage (V_S), the load and operating current (I_L and I_Q), reference's reverse breakdown voltage (V_R).

$$R_S = (V_S - V_R) / (I_L + I_Q)$$

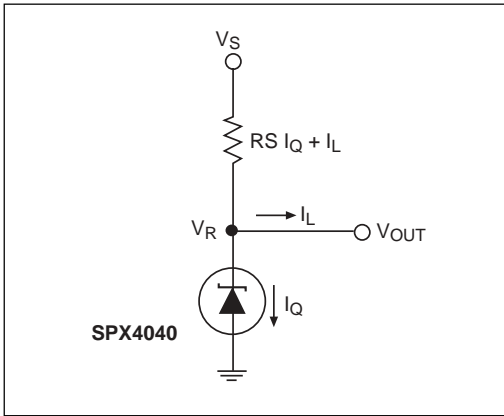

Figure 11. SPX4040 Fixed Shunt Regulator Application

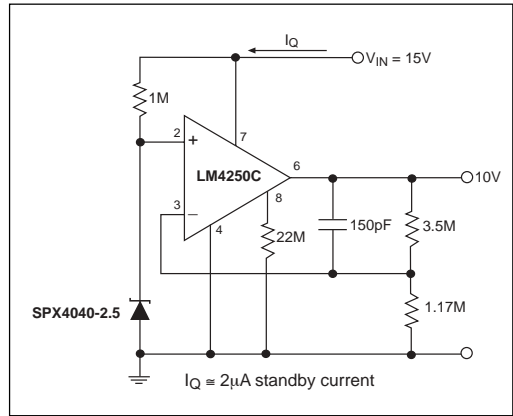

Figure 12. Micropower 10V Reference

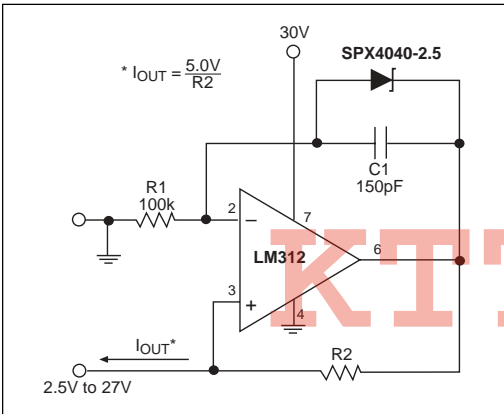

Figure 13. Precision 1µA to mA Current Source

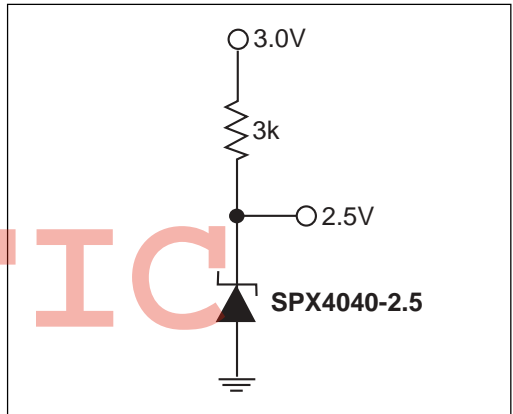

Figure 14. Reference from 3.0V Battery

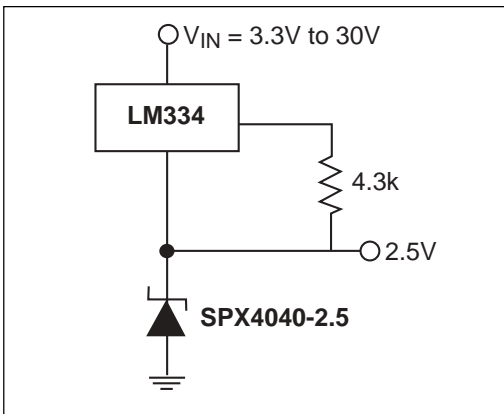
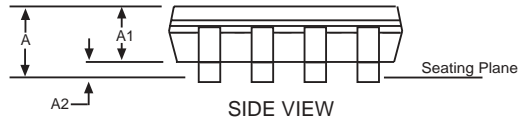
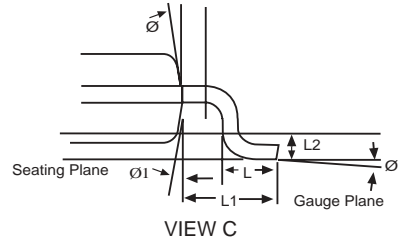
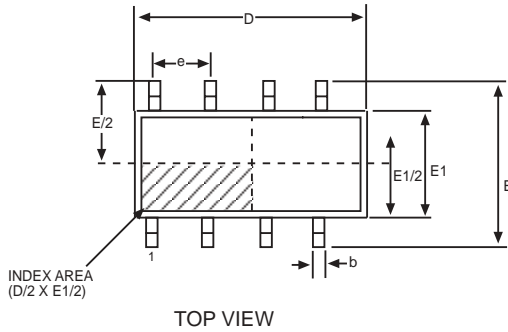
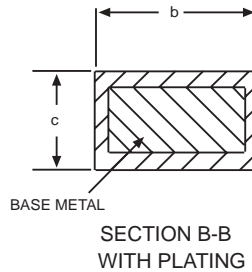
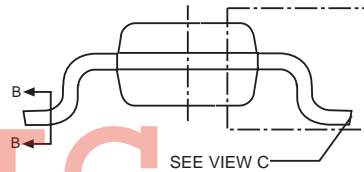

Figure 15. Wide Input Range Reference



8 Pin NSOIC JEDEC MO-012 (AA) Variation			
SYMBOL	MIN	NOM	MAX
A	1.35	-	1.75
A1	0.1	-	0.25
A2	1.25	-	1.65
b	0.31	-	0.51
c	0.17	-	0.24
D	4.90 BSC		
E	6.00 BSC		
E1	3.90 BSC		
e	1.27 BSC		
L	0.4	-	1.27
L1	1.04 REF		
L2	0.25 BSC		
Ø	0°	-	8°
Ø1	5°	-	15°

Note: Dimensions in (mm)



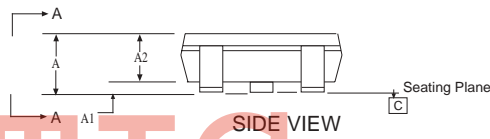
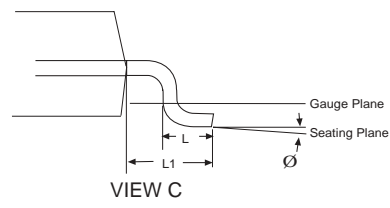
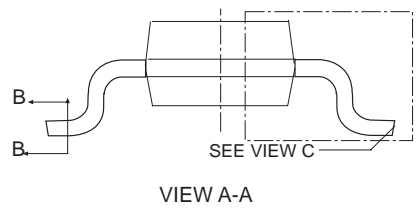
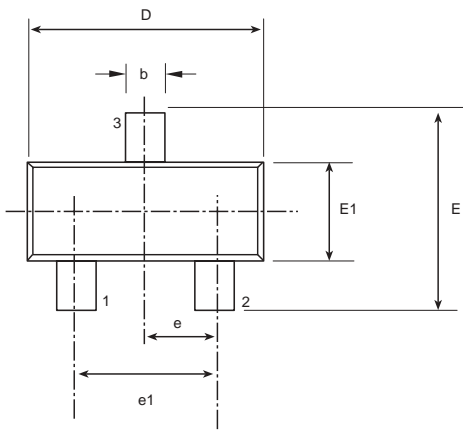

3 Pin SOT-23 JEDEC TO-236 (AB) Variation			
SYMBOL	MIN	NOM	MAX
A	0.89	-	1.12
A1	0.01	-	0.1
A2	0.88	0.95	1.02
b	0.3	-	0.5
c	0.08	-	0.2
D	2.8	2.9	3.04
e	0.95 BSC		
e1	1.90 BSC		
E	0.95	-	2.64
E1	1.2	1.3	1.4
L	0.4	0.5	0.6
L1	0.54 REF		
Ø	0°	-	8°

Note: Dimensions in (mm)

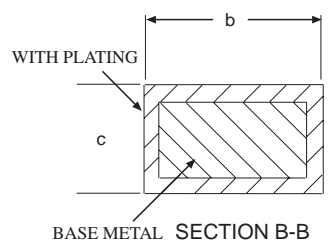

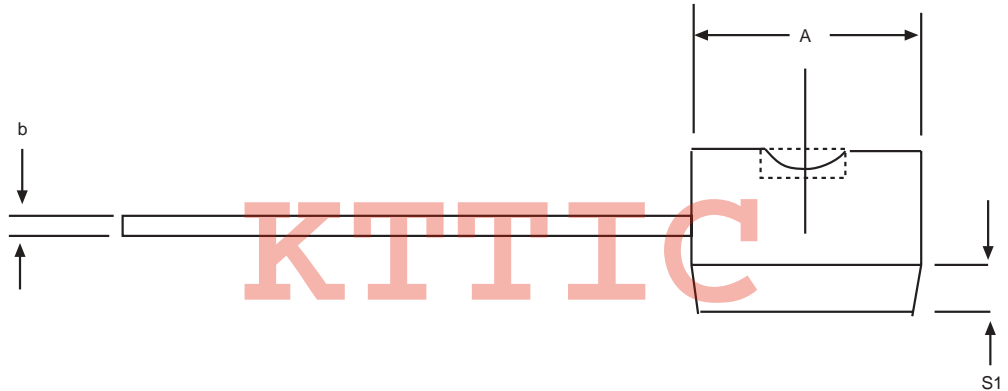
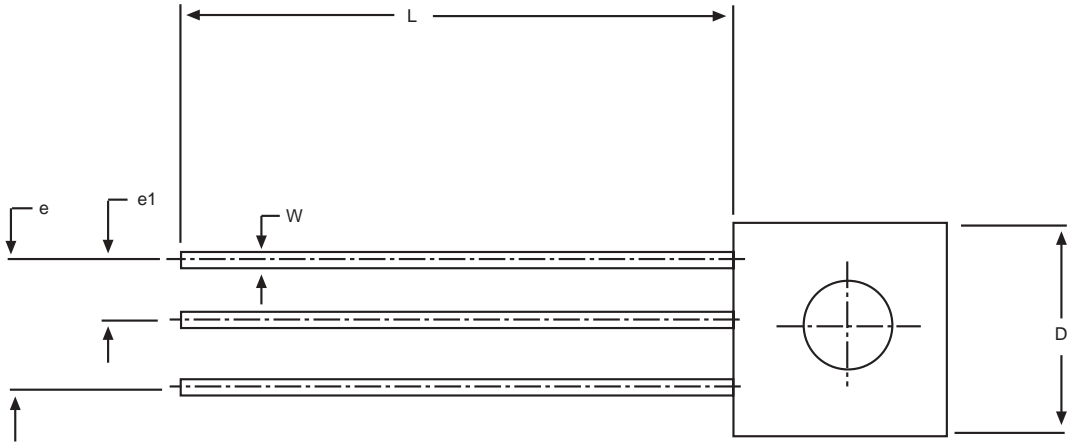

3 Pin TO-92			
SYMBOL	MIN	NOM	MAX
A	0.17	-	0.195
b	0.014	-	0.02
E	0.13	-	0.155
e	0.95	-	0.105
e1	0.045	-	0.055
L	0.5	-	0.61
R	0.085	-	0.095
S1	0.045	-	0.06
W	0.016	-	0.022
D	0.175	-	0.195
a	4°	-	6°

Note: Dimensions in (inches)

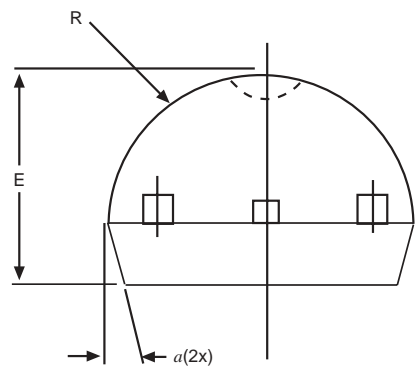

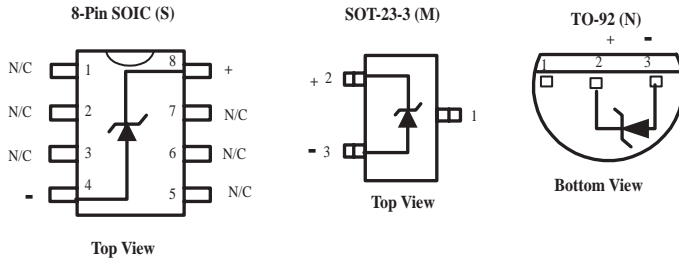

ORDERING INFORMATION

PART NUMBER	ACC	OUTPUT VOLTAGE	PACKAGES
SPX4040AM-2.5	0.5%	2.5V	3-Pin SOT-23
SPX4040AM-2.5/TR	0.5%	2.5V	3-Pin SOT-23
SPX4040AN-2.5	0.5%	2.5V	3-Pin TO-92
SPX4040AN-2.5/TR	0.5%	2.5V	3-Pin TO-92
SPX4040AS-2.5	0.5%	2.5V	8-Pin NSOIC
SPX4040AS-2.5/TR	0.5%	2.5V	8-Pin NSOIC
SPX4040M-2.5	1.0%	2.5V	3-Pin SOT-23
SPX4040M-2.5/TR	1.0%	2.5V	3-Pin SOT-23
SPX4040N-2.5	1.0%	2.5V	3-Pin TO-92
SPX4040N-2.5/TR	1.0%	2.5V	3-Pin TO-92
SPX4040S-2.5	1.0%	2.5V	8-Pin NSOIC
SPX4040S-2.5/TR	1.0%	2.5V	8-Pin NSOIC

Available in lead free packaging. To order add "-L" suffix to part number.
 Example: SPX4040S-2.5/TR = standard; SPX4040S-L-2.5/TR = lead free

/TR = Tape and Reel

Pack quantity is 2,000 for TO-92, 2,500 for NSOIC and SOT-23.

[CLICK HERE TO ORDER SAMPLES](#)



ANALOG EXCELLENCE

Sipex Corporation

Headquarters and Sales Office
 233 South Hillview Drive
 Milpitas, CA 95035
 TEL: (408) 934-7500
 FAX: (408) 935-7600

Sipex Corporation reserves the right to make changes to any products described herein. Sipex does not assume any liability arising out of the application or use of any product or circuit described herein; neither does it convey any license under its patent rights nor the rights of others.