

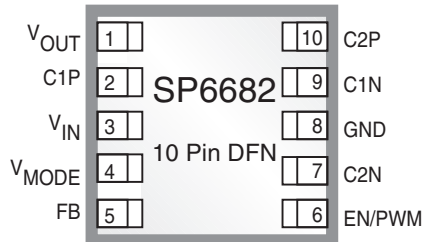

## High Efficiency Charge Pump Regulator for White LEDs

### FEATURES

- Ideal For White LED Driver
- Low Profile, Inductorless Regulator
- X1.5 and X2 Modes for Highest Efficiency
- +2.7V to +5.5V Input Voltage Range
- Fast Turn-On Time, 175µS
- 1mA Quiescent Current
- <1.5µA Shutdown Current
- Built-in 600kHz Oscillator
- Programmable Output Current or Voltage
- PWM Dimming Control with Enable Pin
- Shutdown to Disconnect Output from Input
- Soft Start to Eliminate In-Rush Current
- Industry Standard 10-pin MSOP Package and Small 10-pin DFN Package



*Now Available in Lead Free Packaging*

### APPLICATIONS

- Next Generation Mobile Phones
- PDAs
- 3.3V to 5.0V Conversion
- Digital Still Cameras
- Digital Camcorders
- Palmtop Computers
- Color LCD Modules

### DESCRIPTION

The SP6682 is a current regulated charge pump ideal for converting a Li-Ion battery input for driving white LED used in backlighting color displays. The charge pump automatically switches between X1.5 and X2 modes based on the input voltage, providing improved efficiency over traditional methods using charge pump doubler followed by LDO. This input voltage threshold can be externally programmed for optimized efficiency at specific output voltages and currents. The SP6682 operates with an internal 600kHz clock, enabling the use of small external components. Output current or voltage can be accurately regulated by modulating the switcher between the charge pump and output capacitor. In shutdown mode, the IC disconnects the output from the input and draws less than 1.5µA current. The SP6682 is offered in a 10-pin MSOP package, and a small 10-Pin DFN Package.

### TYPICAL APPLICATION SCHEMATIC

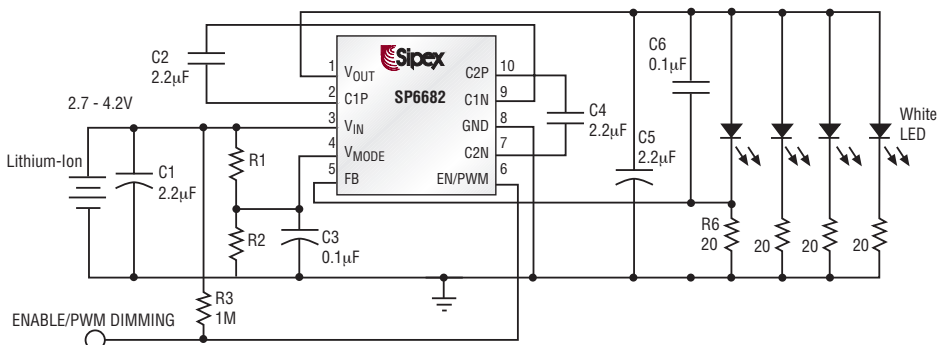

**ABSOLUTE MAXIMUM RATINGS**

$V_{IN}$ ,  $V_{MODE}$ ,  $V_{OUT}$  and EN/PWM ..... -0.3V to 6V  
 $V_{IN} - V_{OUT}$  ..... 0.7V  
 Output Current ( $I_{OUT}$ ) ..... 120mA  
 Power Dissipation per Package - 10-pin MSOP  
 (derate 8.84mW/°C above +70°C) ..... 720mW  
 Junction Temperature ..... +125°C  
 Storage Temperature ..... -65°C to +150°C  
 ESD Rating ..... 2kV HBM

These are stress ratings only and functional operation of the device at these ratings or any other above those indicated in the operation sections of the specifications below is not implied. Exposure to absolute maximum rating conditions for extended periods of time may affect reliability.

**ELECTRICAL CHARACTERISTICS**

Unless otherwise specified:  $V_{IN} = +2.7V$  to  $+5.0V$ ,  $C1=C2=C4=C5=2.2\mu F$  (ceramic,  $ESR=0.03\Omega$ ),  $C3=0.1\mu F$  (ceramic) and  $T_{AMB} = -40^\circ C$  to  $+85^\circ C$  unless otherwise noted.

PARAMETER	MIN	TYP	MAX	UNITS	CONDITIONS
Input Voltage	2.7		5.5	V	
Quiescent Current		1.2	3	mA	$V_{IN} = 4.2V$ , $V_{OUT} = 3.6V$ , $I_{OUT} = 100\mu A$
Shutdown Current			1.5	$\mu A$	EN/PWM = 0V, $V_{IN} = 5.5V$
Oscillator Frequency	0.42	0.60	0.78	MHz	$V_{IN} = 3.6V$
$V_{FB}$ Reference Voltage	0.275	0.306	0.337	V	
Charge Pump Output Resistance		11	18	$\Omega$	FB = 0V, $V_{IN} = 3.6V$ , $I_{OUT} = 20mA$ , $V_{MODE} = High$
$V_{MODE}$ Threshold Voltage	1.15	1.25	1.35	V	$V_{IN}$ Falling @ 25°C
Hysteresis for Mode Transition Voltage		30		mV <sub>PP</sub>	$V_{IN} = 3.6V$ @ 25°C
$V_{MODE}$ Pin Current		0.01	0.5	$\mu A$	$V_{MODE} = 1.25$
EN/PWM Logic Low			0.4	V	
EN/PWM Logic High	1.6			V	
EN/PWM Pin Current		0.01	0.5	$\mu A$	$V_{EN/PWM} = 4.2V$
FB Pin Current			0.5	$\mu A$	$V_{FB} = 1V$
$V_{OUT}$ Turn-On Time		175	500	$\mu s$	$V_{IN} = 3.6V$ , FB within 90% regulation

PIN NUMBER	PIN NAME	DESCRIPTION
1	V <sub>OUT</sub>	Regulated charge pump output.
2	C1P	Positive terminal to the charge pump flying capacitor C2.
3	V <sub>IN</sub>	Input pin for the 2.7V to 5.5V supply voltage.
4	V <sub>MODE</sub>	Charge pump mode program pin. When V <sub>MODE</sub> is greater than 1.25V, X1.5 charge pump is used. Otherwise, charge pump switches to X2 mode. A voltage divider shown in typical application circuit programs the V <sub>IN</sub> threshold for charge pump mode switching.
5	FB	This is the feedback pin for output current or voltage regulation. The voltage of this pin is compared with an internal 306mV reference.
6	EN/PWM	Enable and PWM dimming control input. Pull this pin low to disconnect V <sub>OUT</sub> from V <sub>IN</sub> and shutdown the SP6682.
7	C2N	Negative terminal to the charge pump flying capacitor, C4.
8	GND	Ground reference.
9	C1N	Negative terminal to the charge pump flying capacitor, C2.
10	C2P	Positive terminal to the charge pump flying capacitor C4.

FUNCTIONAL DIAGRAM

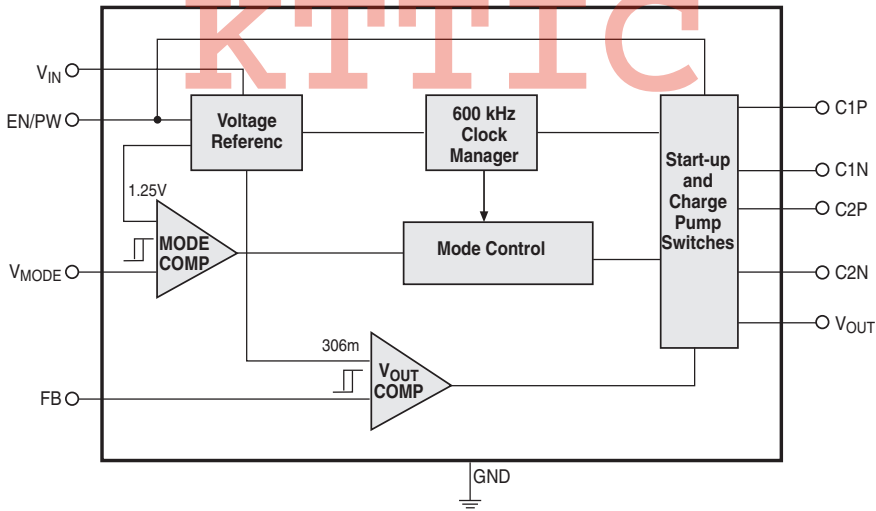

Refer to the typical application circuit,  $T_{AMB} = 25^{\circ}\text{C}$ ,  $I_O = 60\text{mA}$  unless otherwise specified.

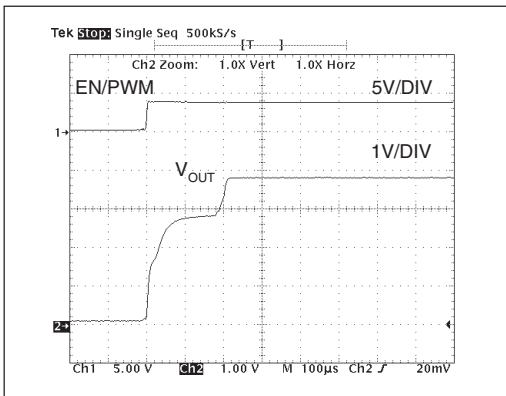

Figure 1. Output voltage turn-on time

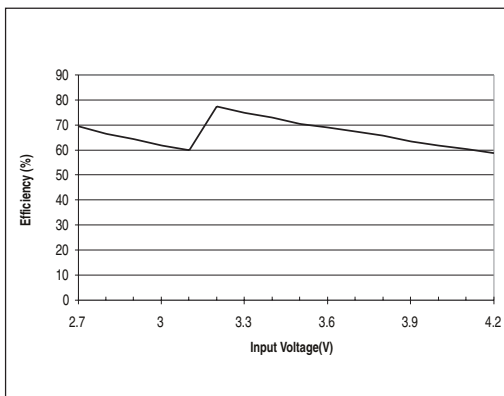

Figure 2. Power efficiency vs. input voltage

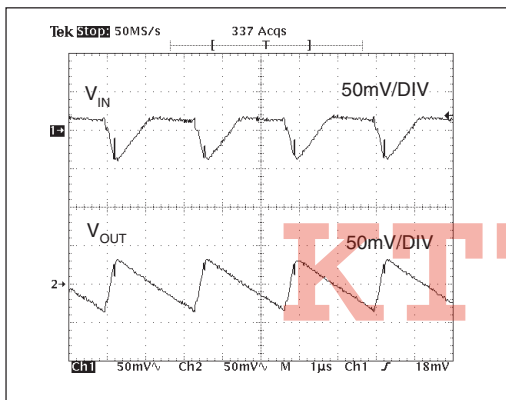

Figure 3. X2 mode voltage ripple when  $V_{IN} = 2.7\text{V}$

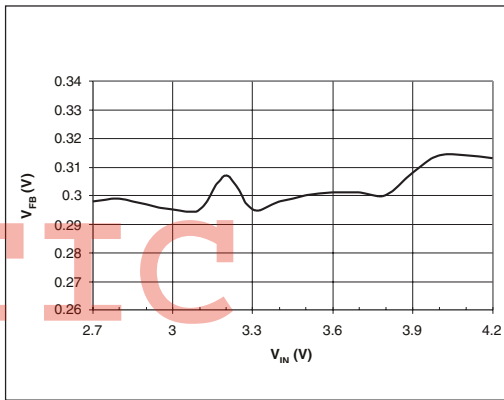

Figure 4. Feedback pin voltage vs. input voltage

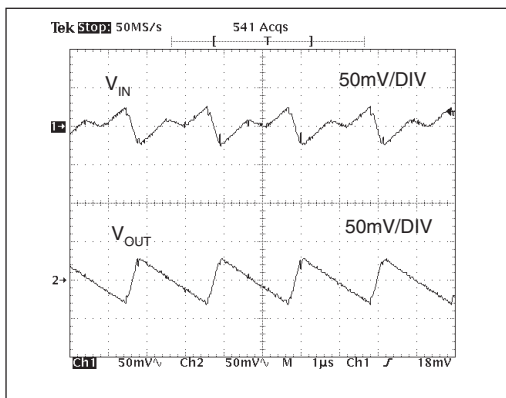

Figure 5. X1.5 mode voltage ripple when  $V_{IN} = 3.3\text{V}$

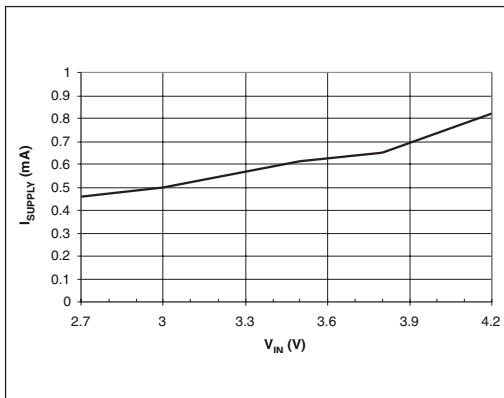

Figure 6. Quiescent current vs. input voltage

Refer to the typical application circuit,  $T_{AMB} = 25^{\circ}\text{C}$ ,  $I_O = 60\text{mA}$  unless otherwise specified.

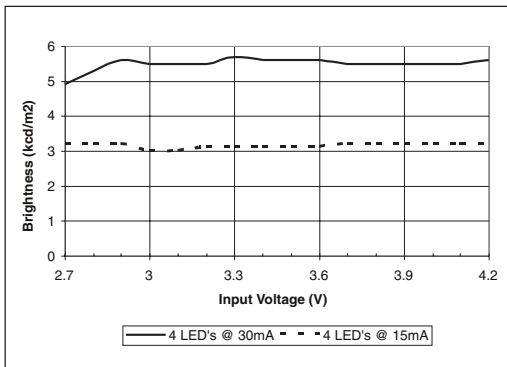

Figure 7. Brightness vs. input voltage

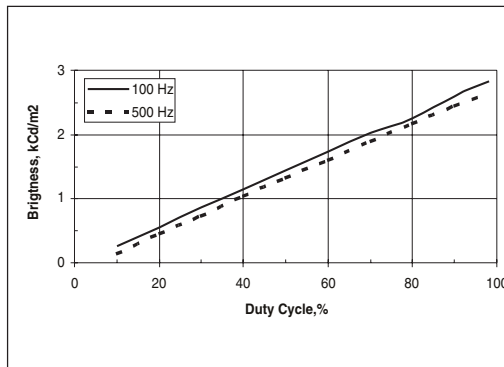

Figure 8. Brightness vs duty cycle

## OPERATION

### General Overview

The SP6682 is a current regulated charge pump ideal for converting a Li-Ion battery input for driving white LEDs used in backlighting color displays in cellular phones, PDAs, digital cameras and MP3 players. The SP6682's proprietary AutoBoost feature enables the IC to automatically transition from X1.5 boost mode to X2 boost mode based on battery input voltage for optimal efficiency and performance. The SP6682 is able to efficiently drive up to six 20mA white LEDs in parallel and maintain a constant brightness over a very wide operating voltage range (2.7V to 5.5V). The SP6682 operates with an internal 600kHz clock, enabling the use of small external components. Other features of SP6682 include PWM dimming control as well as complete input/out disconnect in shutdown. In shut down mode the IC draws less than 1.5 $\mu\text{A}$  current. The output regulation is achieved by sensing the voltage at the feedback pin and modulating the switcher between the charge pump and output capacitor.

### Theory of Operation

The SP6682 regulated charge pump block diagram consists of four main blocks (Voltage Reference, Mode Control, Clock Manager, Start-up and Charge-Pump Switches) and two com-

parators ( $V_{MODE}$  Comparator and  $V_{OUT}$  Comparator).

**1) Voltage Reference.** This block provides the 306mV and 1.25V reference voltages needed for the two comparators.

**2) Mode Control.** An external voltage divider connected to the  $V_{MODE}$  pin will define an input voltage to the mode comparator which sets the logic state of the mode selection outputs to the X2 or X1.5 modes.  $V_{MODE}$  is compared to a 1.25V bandgap voltage. For example, if one makes a 158K/100K divider, the mode will change at  $2.58 \times 1.25 \text{ V} = 3.23\text{V}$ . A comparator-based cycle by cycle regulation ensures that no mode change occurs during cycles.

**3) Clock Manager.** An internal 600 kHz clock is generated in this block. Depending on the mode control, the appropriate clock phasing is generated here and sent to the start-up and charge-pump switches block.

**4) Start-up and Charge Pump Switches.** During start-up, until the reference is established, this block keeps the charge pump inactive. During this period the output stays floating, by consequence the charge pump drivers are now referenced to  $V_{OUT}$ . Charging of the output will occur (e.g. when  $V_{IN}$  is ramped up to 4.2V,  $V_{OUT}$  ramps only up to about 3V), but not to the value of  $V_{IN}$ , protecting the White LED from experi-

encing high input voltages. Another important operation of this block is the PWM/EN dimming control, which is implemented in the delay of each pump driver, so that the enable high pulse width is proportional to the delay of the individual pump switches.

5) **V<sub>OUT</sub> Comparator and Output Control.** A 306mV reference voltage is compared to feed-

back output voltage to control the V<sub>out</sub> needed for the application. Output current is set by a bias resistor from FB pin to GND pin chosen by the relationship:

$$I_{OUT} = \frac{V_{FB}}{R_{FB}}$$

where V<sub>FB</sub> = 306mV.

**APPLICATION INFORMATION**

**Configuring the SP6682 as Voltage or Current Source**

The white LED load configuration used by customers can be discrete white LEDs or a white LED module. Inside the white LED module, there may or may not be resistors in series with the white LEDs. According to the different application requirements, the SP6682 can be configured as either a voltage source or a current source to provide solutions for these different applications, as shown in figure 9~12. Figure 9 shows using the SP6682 to drive discrete white LEDs as a current source.

The current in one white LED current is set by the ratio of the feedback pin voltage (306mV) and the bias resistor R<sub>B</sub>. To set the operating current, R<sub>B</sub> can be selected by:

$$R_B = \frac{V_{FB}}{I_{LED}}$$

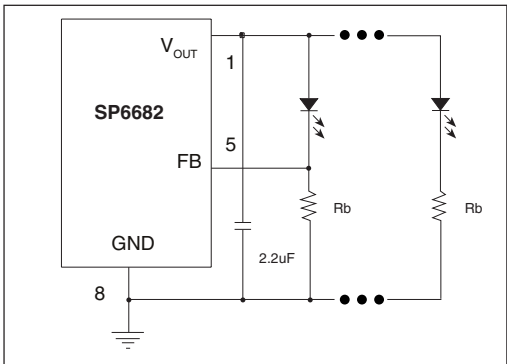

Figure 9. Driving discrete white LEDs as current source

The current of the remaining white LEDs is set according to the similarity of the white LEDs. 3-wire white LED module with internal series resistors as shown in figure 10 can also be driven in this way.

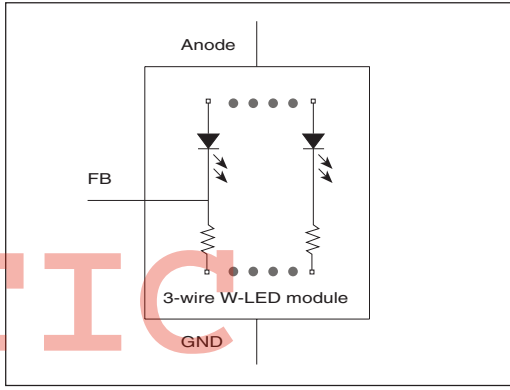

Fig 10. 3-wire white LED module

In figure 11, SP6682 was used to drive a 2-wire white LED module without internal series resistors as a current source. The bias resistor R<sub>B</sub> is selected to regulate the total current of the white LED module instead of the current of single LED as in figure 9.

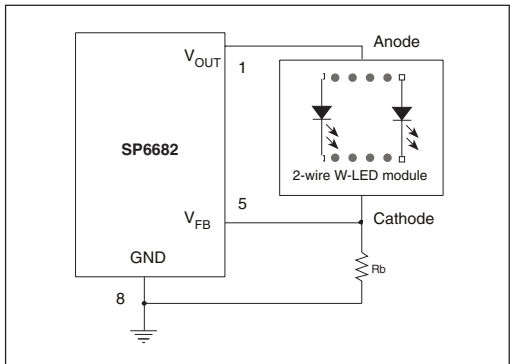

Figure 11. Driving 2-wire white LED module as current source

In this application, the bias resistor can be selected by:

$$R_B = \frac{V_{FB}}{I_{LED(TOTAL)}}$$

where  $I_{LED(TOTAL)}$  is the total operating current of all the white LEDs.

To use SP6682 as a voltage source for fixed voltage applications, a voltage divider is need to program the output voltage, as shown in figure 12. The output voltage is set by the ratio of the two

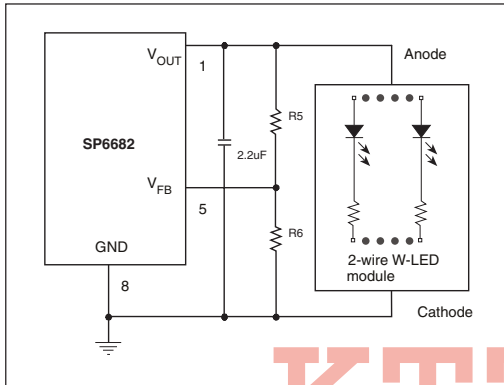

Figure 12. Driving 2-wire white LED module as voltage source

resistors and the feedback control voltage as shown by:

$$V_{OUT} = \left(1 + \frac{R_5}{R_6}\right) \cdot V_{FB}$$

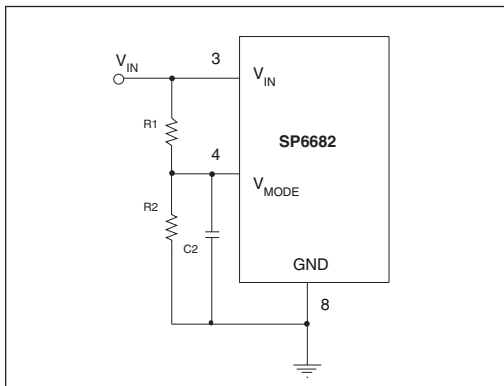

Figure 13. Programming the Vmode Resistors

### Programming the Operating Mode

SP6682 can automatically change from X1.5 mode to X2 mode for highest efficiency. To use this feature, divider resistors should be chosen according to the specific application, as shown in figure 13.

The guideline for divider resistor selections is as follows. For high input voltage, the SP6682 will work in X1.5 mode. When the input voltage drops to  $V_{th}$  threshold voltage, it will switch to X2 mode automatically. The  $V_{th}$  threshold voltage for mode change can be calculated by:

$$V_{TH} = (V_F + 0.306 + m \cdot I_{LED} \cdot R_{OUT})/1.5$$

Where  $V_F$  and  $m$  are the forward voltage and number of the white LEDs,  $R_{out}$  is the output resistance of the SP6682.

The equation for the voltage divider  $R_1$  and  $R_2$  with  $V_{MODE} = 1.25V$  is:

$$V_{TH} = 1.25V \cdot (1 + R_1/R_2)$$

which can be expressed as  $R_1$ :

$$R_1 = (V_{TH} / 1.25 - 1) \cdot R_2$$

For the typical SP6682 application, Using  $V_F=3.6V$ ,  $m=4$ ,  $I_{LED}=15mA$ ,  $R_{OUT}=16\Omega$ , the  $V_{TH}$  will be  $3.24V$ . Select  $R_2=100k\Omega$ , then  $R_1=158k\Omega$ .

### Capacitor Selection

Ceramic capacitors are recommended for their inherently low ESR, which will help produce low peak to peak output ripple, and reduce high frequency spikes.

The fly capacitor controls the strength of the charge pump. Selection of the fly capacitor is a trade-off between the output voltage ripple and the output current capability. Decreasing the fly capacitor will reduce the output voltage ripple because less charge will be delivered to the output capacitor. However, smaller fly capaci-

tor leads to larger output resistance, thus decreasing the output current capability and the circuit efficiency. Place all the capacitors as close to the SP6682 as possible for layout. Increasing the value of the input and output

capacitors could further reduce the input and output ripple.

Refer to Table 1 for some suggested low ESR capacitors.

**Table: 1**

**SUGGESTED LOW ESR CAPACITORS**

MANUFACTURERS/ TELEPHONE#	PART NUMBER	CAPACITANCE/ VOLTAGE	CAPACITOR/ SIZE/TYPE	ESR AT 100kHz
TDK/847-803-6100	C2012X5R1A225K	2.2µF/10V	0805/X5R	0.030Ω
TDK/847-803-6100	C2012X5R0J475K	4.7µF/6.3V	0805/X5R	0.020Ω
MURATA/770-436-1300	GRM188R60J225KE01D	2.2µF/6.3V	0603/X5R	0.030Ω
MURATA/770-436-1300	GRM219R60J475KE01D	4.7µF/6.3V	0805/X5R	0.020Ω

**Brightness Control Using PWM**

Dimming control can be achieved by applying a PWM control signal to the EN/PWM pin. The brightness of the white LEDs is controlled by increasing and decreasing the duty cycle of the PWM signal. While the operating frequency range of the PWM control is from 60Hz to 700Hz, the recommended maximum brightness frequency range of the PWM signal is from 60Hz to 200Hz. A repetition rate of at least 60Hz is required to prevent flicker.

tional to the operating current, for better brightness matching, a higher output voltage could be used. This could be done by using larger resistor, as shown in figure 14. Rb2 is used to bias the operating current of the white LED, Rb1 is use to increase the output voltage. Better brightness matching was achieved at the cost of the power wasted on the bias resistor.

**Brightness Matching**

For white LEDs, the forward voltage drop is a function of the operating current. However, for a given current, the forward voltage drops do not always match due to normal manufacturing tolerance, thus causing uneven brightness of the white LEDs.

In figure 14, assume high-precision bias resistors were used, the operating current ratio of two different branches can be easily derived as shown by:

$$\frac{I_1}{I_2} = \frac{V_{OUT} - V_{F1}}{V_{OUT} - V_{F2}}$$

where I<sub>1</sub> I<sub>2</sub> are the operating current of the white LEDs, V<sub>F1</sub>, V<sub>F2</sub> are the forward voltage of the white LEDs.

Since the brightness of the white LED is propor-

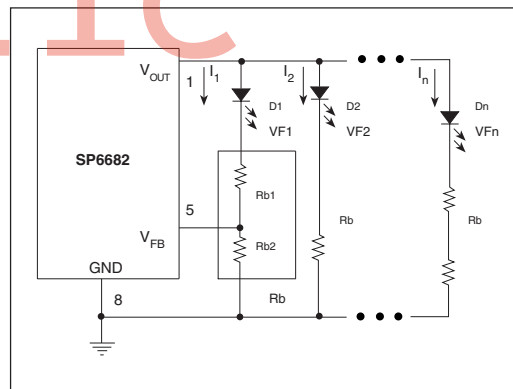

**Figure 14. Increasing brightness matching**

**Power Efficiency**

The efficiency of driving the white LEDs can be calculated by:

$$\eta = \frac{V_F \cdot I_F}{V_i \cdot I_i} = \frac{V_F \cdot I_F}{V_i \cdot (n \cdot I_F + I_Q)} \approx \frac{V_F}{V_i \cdot n}$$



Where  $V_i$ ,  $I_i$  are input voltage and current  $V_F$ ,  $I_F$  are the forward voltage and operating current of White LEDs  $I_Q$  is quiescent current, which is considered small compared with  $I_F$ .

$n$  is the boost ratio (X1.5 or X2)

this application as well as actual data showing efficiency of >85%. By using an external inductor, MOSFET and diode, high output voltage can be generated to drive 12 white LEDs (2 branches, each branch has 6 white LEDs in series). The current through the white LEDs is determined by:

$$I_{LED} = \frac{V_{FB}}{R_1}$$

**SP6682 High Voltage White LED Driver**

The SP6682 can also be configured as a high voltage boost converter to drive more than 10 white LEDs. Figure 15 shows the schematic of

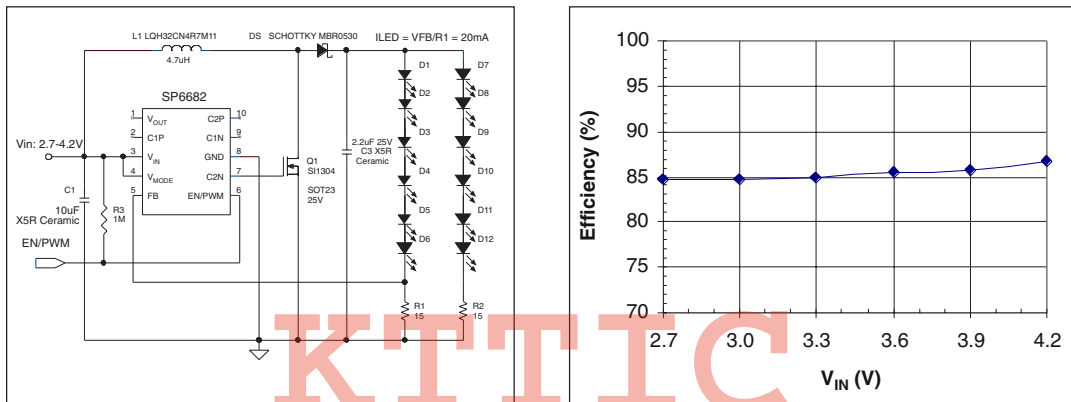
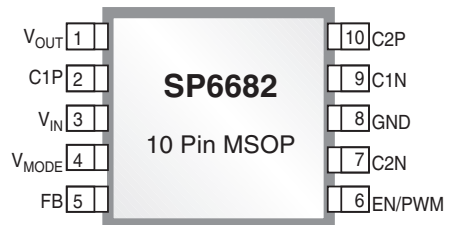
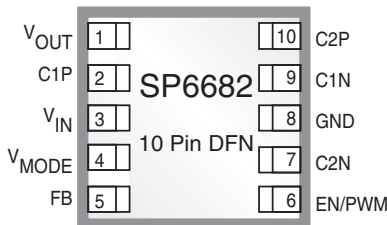
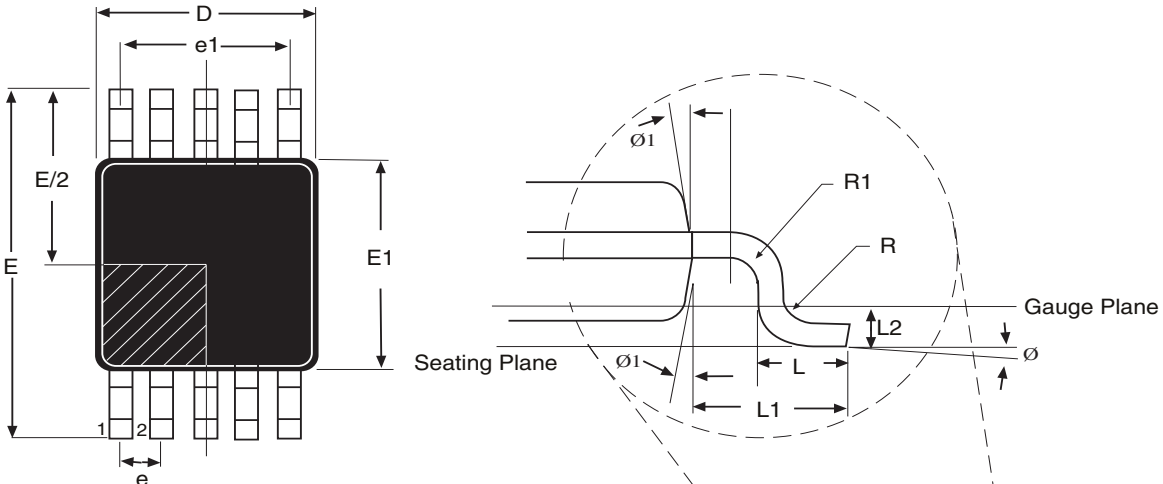

Figure 15. Using SP6682 as a High Voltage White LED Driver

**PINOUTS**



(ALL DIMENSIONS IN MILLIMETERS)



Pin #1 identifier must be indicated within this shaded area ( $D/2 * E1/2$ )

Dimensions in (mm)	10-PIN MSOP JEDEC MO-187 (BA) Variation		
	MIN	NOM	MAX
A	-	-	1.1
A1	0	-	0.15
A2	0.75	0.85	0.95
b	0.17	-	0.27
c	0.08	-	0.23
D	3.00 BSC		
E	4.90 BSC		
E1	3.00 BSC		
e	0.50 BSC		
e1	2.00 BSC		
L	0.4	0.60	0.80
L1	-	0.95	-
L2	-	0.25	-
N	-	10	-
R	0.07	-	-
R1	0.07	-	-
Ø	0°	-	8°
Ø1	0°	-	15°

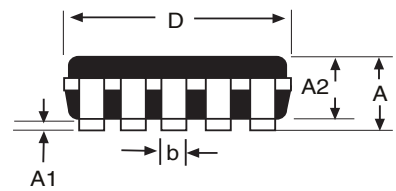
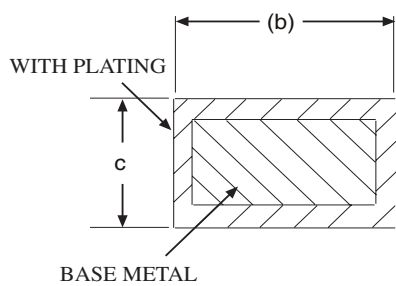
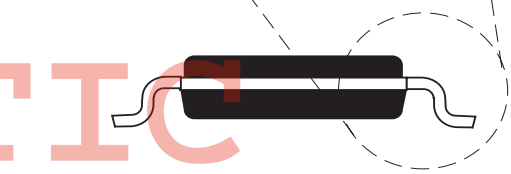

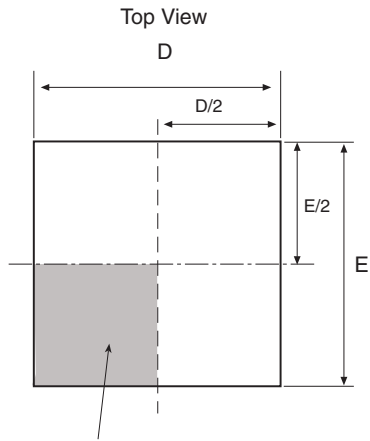

Pin 1 identifier to be located within this shaded area.  
Terminal #1 Index Area ( $D/2 * E/2$ )

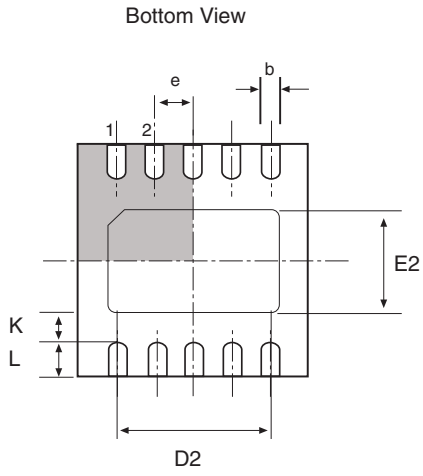

KTTIC

SYMBOL	DIMENSIONS in (mm)		
	MIN	NOM	MAX
A	0.80	0.90	1.00
A1	0	0.02	0.05
A3	0.20 REF		
b	0.18	0.25	0.30
D	3.00 BSC		
D2	2.20	-	2.70
e	0.50 PITCH		
E	3.00 BSC		
E2	1.40	-	1.75
K	0.20		
L	0.30	0.40	0.50

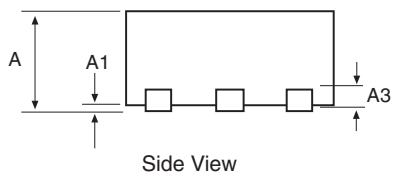

10 PIN DFN

Part Number	Top Mark	Operating Temperature Range	Package Type
SP6682EU .....	SP6682EU.....	40°C to +85°C .....	10 Pin MSOP
SP6682EU/TR .....	SP6682EU.....	40°C to +85°C .....	10 Pin MSOP
SP6682ER .....	SP6682EURYWW.....	40°C to +85°C .....	10 Pin DFN
SP6682ER/TR .....	SP6682ERYWW.....	40°C to +85°C .....	10 Pin DFN

Available in lead free packaging. To order add "-L" suffix to part number.

Example: SP6682ER/TR = standard; SP6682ER-L/TR = lead free

/TR = Tape and Reel

Pack quantity is 2,500 for MSOP and 3,000 for DFN.



ANALOG EXCELLENCE

Sipex Corporation

**Headquarters and Sales Office**  
233 South Hillview Drive  
Milpitas, CA 95035  
TEL: (408) 934-7500  
FAX: (408) 935-7600

Sipex Corporation reserves the right to make changes to any products described herein. Sipex does not assume any liability arising out of the application or use of any product or circuit described herein; neither does it convey any license under its patent rights nor the rights of others.

This datasheet has been download from:

[www.datasheetcatalog.com](http://www.datasheetcatalog.com)

Datasheets for electronics components.

KTTIC