

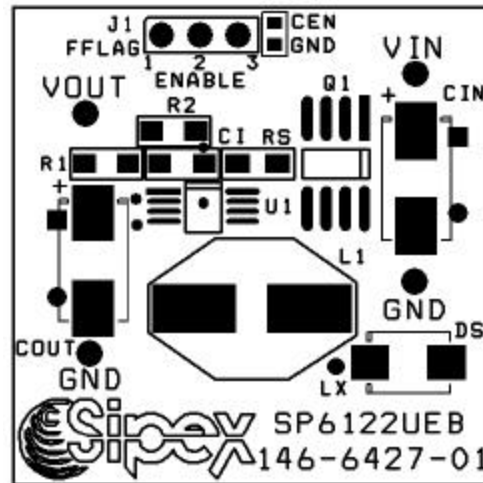

## SP6122 Evaluation Board Manual

- Easy Evaluation for the SP6122 Low Voltage PFET Buck Converter
- Ideal for 1A to 5A, Small Footprint, DC-DC Power Converters
- Very Accurate 1.5% Reference over Line, Load, Temperature
- Small Micro 8 Package



### DESCRIPTION

The **SP6122 Evaluation Board** is designed to help the user evaluate the performance of the SP6122 for use as a **low voltage input, low voltage output** PFET Buck DC-DC Controller. The SP6122 operates from a 5V or 3.3V input supply, and delivers output voltages as low as 1.5V with an accuracy of 1.5% over line, load and temperature. Unlike other "Micro-8" parts, the SP6122 has an array of value added features for you to evaluate including: optional hiccup mode, over-current protection and fault flag output.

The evaluation board is a completely assembled and tested surface mount power supply board which provides easy access to the SP6122 Input and Outputs so that the user can quickly measure electrical characteristics and waveforms.

The next two sections describe the SP6122 Board Layout and Using the SP6122 Evaluation Boards. A section on SP6122 Power Supply Data is also included with graphs on Efficiency, Line and Load Regulation. Then, drawings of the PC Layout and a schematic are included as a design-in tool for the user of the SP6122. Finally, a SP6122 Evaluation Board List of Materials table is provided with some manufacturers part numbers to use as a reference.

### BOARD LAYOUT

The **SP6122 Evaluation Board** has been designed for quick and easy connection to the Input and Output of the SP6122 Power Supply under test. Position the board with the silkscreen lettering upright, (also see the drawing on the front page of this manual) and you will see U1 the SP6122 8-pin  $\mu$ SOIC, in the center left of the board. To the left of U1 are the output capacitor COUT and the Vout pin. To the right of U1 are Q1 and the Vin post and the input capacitor Cin. Below Cin and COUT are the two GND posts.

**1) Powering Up the SP6122 Circuit**

The SP6122 Evaluation Board can be powered from inputs from a +3V to +7V power supply. Connect with short leads directly to the “Vin” and “Gnd” posts. Monitor the Output Voltage and connect the Load between the “Vout” post and the 2<sup>nd</sup> “GND” post.

**2) Using the J1 Jumper: Enabling the SP6122 Output and using the Hiccup Mode**

As you can see in table 1, the SP6122 output will be Enabled if the J1 Jumper is left open. If J1 is in the pin 2 to 3 position, the ENABLE pin is brought to GND, which puts the SP6122 in the Sleep Mode. If the Jumper at J1 is in the pin 1 to 2 position, FFLAG U1 pin 2 is connected to ENABLE U1 pin 4, and Hiccup Mode is activated. Hiccup Mode occurs if the output current exceeds the Over-Current-Protection threshold, and the part will “Soft-start”, which happens every 1.2msec for a CEN capacitor value of 4.7nF. This is determined by the following relationship:

$$I = CEN \cdot dV/dt \quad \text{which yields} \quad dt = CEN \cdot dV/I = 1.2\text{msec}$$

where the value of the CEN capacitor is 4.7nF, dV is the 1V internal threshold for charging, and I is the Enable pin source current of 4uA.

J1 Position	SP6122	
	Mode	Condition
open	Enabled	Normal
1 to 2	Hiccup	Softstarts if Over-Current
2 to 3	Sleep	I <sub>q</sub> = 20uA (max)

**Table 1. SP6122 Enable/Hiccup Jumper**

**3) Using External Divider Resistors: Programming the SP6122 Output Voltage**

As you can see by the schematic in Figure 1, the SP6122 uses an internal feedback divider to initially trim the output voltage using Rin1 and Rin2, where Rin2 is approximately 62.5K. To accommodate the user who wants to externally program the SP6122 output voltage, the SP6122 Evaluation Board has 2 external divider resistors, R1 and R2, which can be used to program the output voltage above, but not below the voltage set by the internal resistor divider. The relationships for the external divider resistors are derived below:

$$i1 = Va/Rin2 = 1.25/62.5K = 20uA$$

Since Rin2 has +/-50% tolerance, ib change is +20uA/-7uA. If the SP6122 is trimmed to 1.5V output, Vb will be fixed at 1.5V in a closed loop. As a result, i2 is not affected by the variation of the internal resistors, and the +20uA/-7uA current variation will be passed on to i3.

$$Vout = Vb + i3 \cdot R1,$$

Therefore,  $\Delta Vout = \Delta i3 \cdot R1 = +20uA/-7uA \cdot R1.$

That is, the additional variation on the output voltage is caused by the internal voltage divider. For example, with R1 selected to be 500ohm, the variation on the output voltage will be +10mV/-3.5mV.

**SP6122 Evaluation Board Divider Resistors:** The values of R1 and R2 are selected to program 1.9V output, with 1.5V trim voltage Vb, and R1 = 500ohm:

$$i_3 = (V_{out} - V_b) / R_1 = (1.9 - 1.5) / 500 = 800\mu A.$$

The external voltage divider will add only 800uA to the load. **Divider Resistor R2 is:**

$$R_2 = V_b / (i_3 - i_1) = 1.5 / (800\mu A - 20\mu A) = 1.9K$$

The user of the SP6122 Evaluation Board can use the above equations for i3 and R2 to modify R2 and change the output voltage to be any voltage from Vb (1.5V) to as high as the input voltage. And if you want the output voltage to be the preset voltage Vb (1.5V), just short a wire across R1.

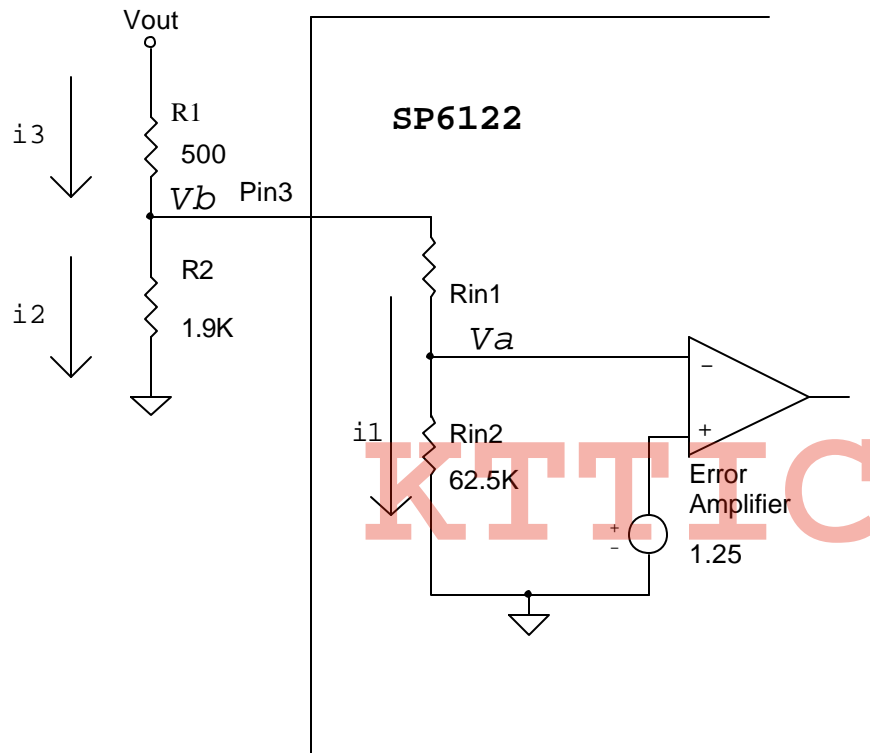

**Figure 1. Schematic: Output Voltage Divider Resistors**

## POWER SUPPLY DATA

The SP6122 is engineered for size and minimum pin count, yet has a very accurate 1.5% reference over line, load and temperature. Figure 2 data shows a typical SP6122 Evaluation Board Efficiency plot, with efficiencies to 88% and output currents to 4A. Load Regulation plot in Figure 3 shows an essentially flat response of only 3mV change for up to 4A load. Figure 4 Line Regulation illustrates a 1.90V output that varies only 4mV or 0.2% for an input voltage change from 3.3V to 5.5V. While data on individual power supply boards may vary, the capability of the SP6122 of achieving high accuracy over load and line shown here is quite impressive and desirable for accurate power supply design.

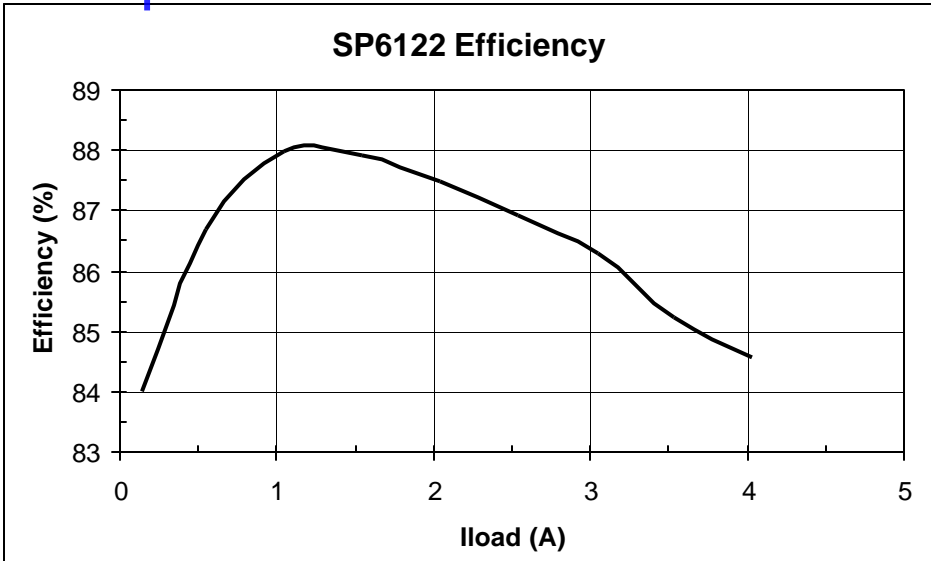

Figure 2. SP6122 Efficiency with Vin = 3.3V, Vout = 1.93V

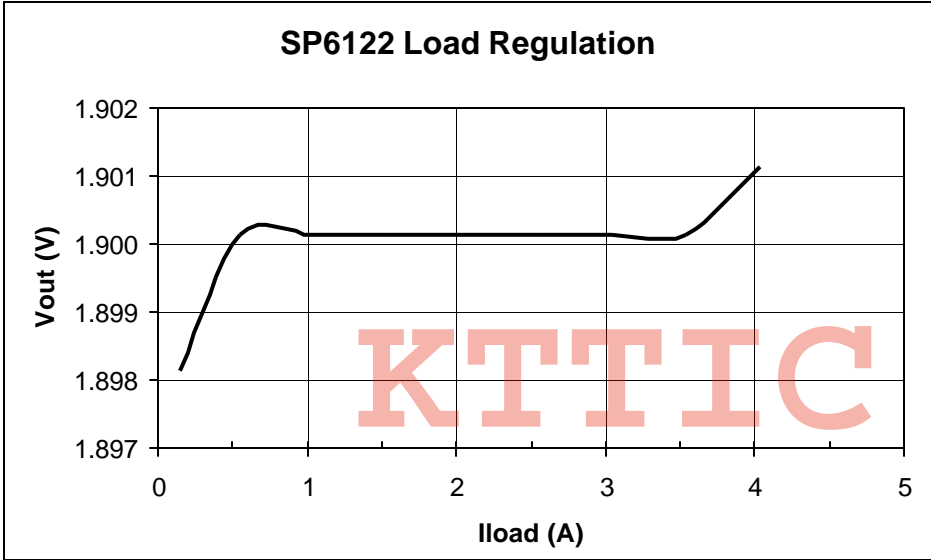

Figure 3. SP6122 Load Regulation with Input Voltage = 3.3V

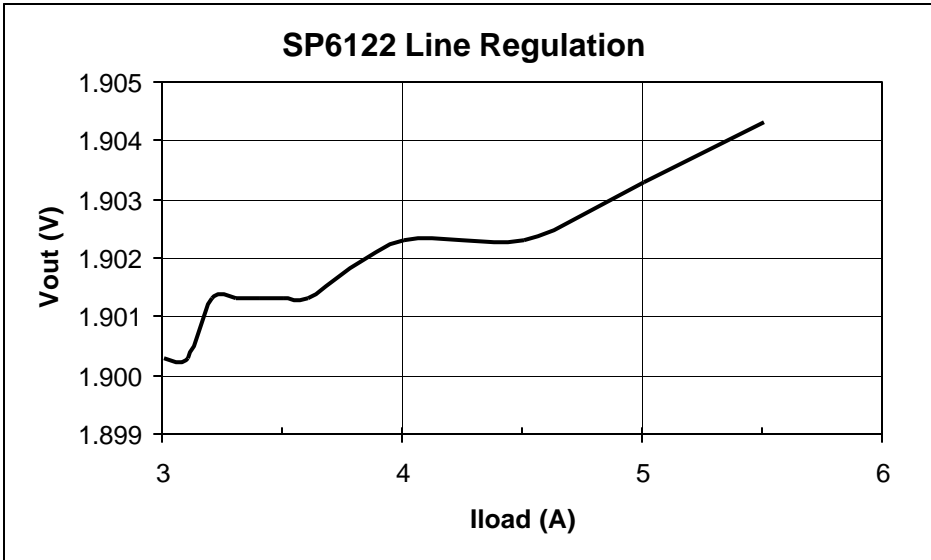

Figure 4. SP6122 Line Regulation with Iload = 2A

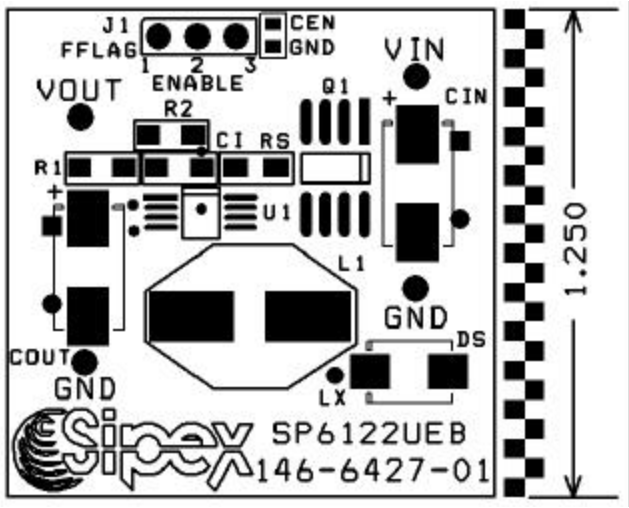

FIGURE 5: SP6122UEB COMPONENT PLACEMENT

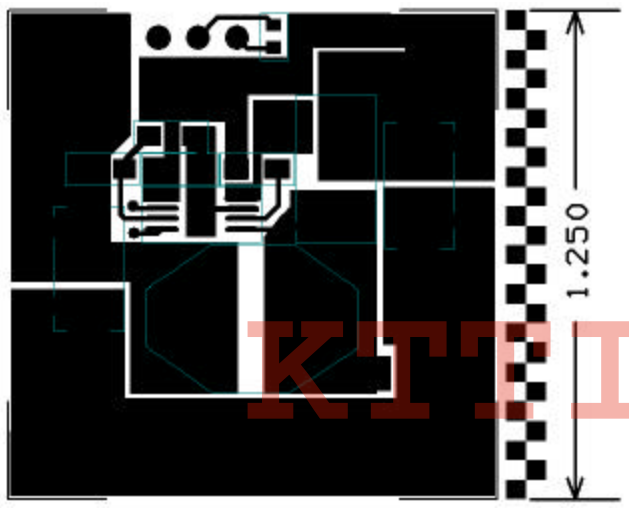

FIGURE 6: SP6122UEB PC LAYOUT TOP SIDE

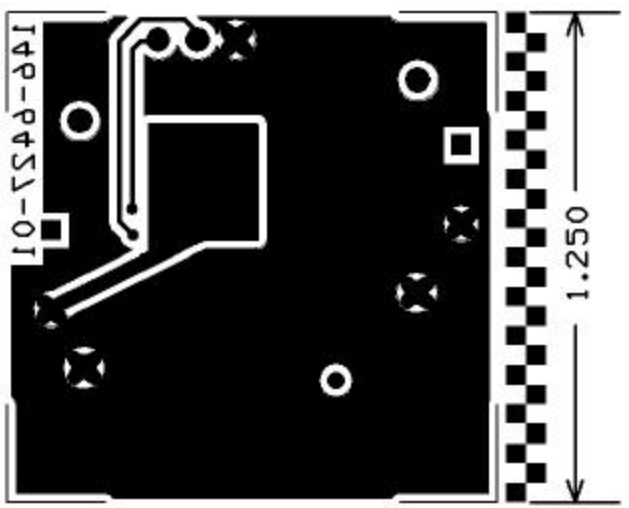

FIGURE 7: SP6122UEB PC LAYOUT BOTTOM SIDE

