



10Mbps, +5V-Only V.35 Interface with RS-232 (V.28) Control Lines

- 10Mbps V.35 Data Throughput
- +5V-Only, Single Supply Operation
- 3 Drivers, 3 Receivers – V.35
- 4 Drivers, 4 Receivers – RS-232
- Improved V.35 Receiver Propagation Delays
- No External V.35 Termination Resistors Required
- Termination Disable for V.35
- 80-pin MQFP Surface Mount Packaging
- Pin Compatible with SP320



Now Available in Lead Free Packaging

DESCRIPTION

The SP319 is a complete V.35 interface transceiver offering 3 drivers and 3 receivers for V.35, and 4 drivers and 4 receivers for RS-232 (V.28). A Sipex patented charge pump allows +5V only low power operation. RS-232 drivers and receivers are specified to operate at 120kbps, all V.35 drivers and receivers operate up to 10Mbps.

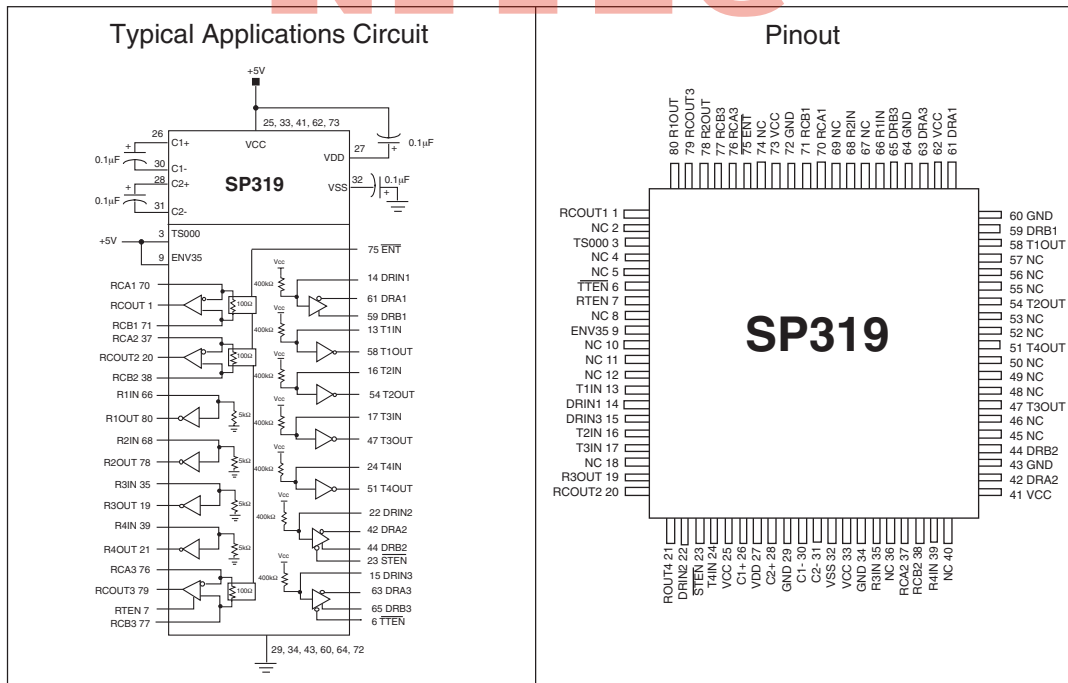

ABSOLUTE MAXIMUM RATINGS

These are stress ratings only and functional operation of the device at these ratings or any other above those indicated in the operation sections of the specifications below is not implied. Exposure to absolute maximum rating conditions for extended periods of time may affect reliability.

V _{CC}	+7V
Input Voltages	
Logic.....	-0.3V to (V _{CC} +0.5V)
Drivers.....	-0.3V to (V _{CC} +0.5V)
Receivers.....	±30V at ≤100mA
Output Voltages	
Logic.....	-0.3V to (V _{CC} +0.5V)
Drivers.....	±14V
Receivers.....	-0.3V to (V _{CC} +0.5V)
Storage Temperature.....	-65°C to +150°C
Power Dissipation per Package	
80-pin QFP (derate 18.3mW/°C above +70°C).....	1500mW

ELECTRICAL SPECIFICATIONS

T_{AMB} = T_{MIN} to T_{MAX} and V_{CC} = 5V±5% unless otherwise noted.

PARAMETER	MIN.	TYP.	MAX.	UNITS	CONDITIONS
V.35 DRIVER					
TTL Input Levels					
V _{IL}	2.0		0.8	Volts	
V _{IH}				Volts	
Voltage Outputs					
Open Circuit Voltage			±1.2	Volts	Refer to <i>Figure 1</i>
Differential Outputs	±0.44	±0.55	±0.66	Volts	R _I = 100Ω from A to B; <i>Figure 2</i>
Source Impedance	50	100	150	Ohms	<i>Figure 4</i>
Short Circuit Impedance	135	150	165	Ohms	Measured from A=B to Gnd,
Voltage Output Offset	-0.6		+0.6	Volts	V _{OUT} = -2V to +2V; <i>Figure 5</i> ; T _{AMB} = +25°C V _{Offset} = (V _A + V _B) / 2; <i>Figure 3</i>
AC Characteristics					
Transition Time		40		ns	T _{AMB} = +25°C for all AC parameters 10% to 90%; <i>Figure 6</i>
Maximum Transmission Rate	10			Mbps	V _{DIFF OUT} = 0.55V±20%; <i>Figure 9</i>
Propagation Delay					
t _{PHL}		80	100	ns	Measured from 1.5V of V _{IN} to 50% of V _{OUT} ; <i>Figure 9, 10</i>
t _{PLH}		80	100	ns	Measured from 1.5V of V _{IN} to 50% of V _{OUT} ; <i>Figure 9, 10</i>
V.35 RECEIVER					
TTL Output Levels					
V _{OL}	2.4		0.4	Volts	I _{OUT} = -3.2mA
V _{OH}				Volts	
Receiver Inputs					
Differential Input Threshold	-0.3		+0.3	Volts	
Input Impedance	90	100	110	Ohms	<i>Figure 7</i>
Short Circuit Impedance	135	150	165	Ohms	Measured from A=B to Gnd V _{IN} = -2V to +2V; <i>Figure 8</i> ; T _{AMB} = +25°C
AC Characteristics					
Maximum Transmission Rate	10			Mbps	T _{AMB} = +25°C for all AC parameters V _{IN} = ±0.55V ±20%; <i>Figure 9</i>
Propagation Delay					
t _{PHL}		60	80	ns	Measured from 50% of V _{IN} to 1.5V of R _{OUT} ; <i>Figure 9, 11</i>
t _{PLH}		60	80	ns	Measured from 50% of V _{IN} to 1.5V of R _{OUT} ; <i>Figure 9, 11</i>

ELECTRICAL SPECIFICATIONS (CONTINUED)

T_{AMB} = T_{MIN} to T_{MAX} and V_{CC} = 5V±5% unless otherwise noted.

PARAMETER	MIN.	TYP.	MAX.	UNITS	CONDITIONS
RS-232 DRIVER					
TTL Input Levels					
V _{IL}			0.8	Volts	
V _{IH}	2.0			Volts	
Voltage Outputs					
High Level Output	+5.0		+15.0	Volts	R _L = 3kΩ to Gnd; <i>Figure 13</i>
Low Level Output	-15.0		-5.0	Volts	R _L = 3kΩ to Gnd; <i>Figure 13</i>
Open Circuit Output	-15		+15	Volts	R _L = ∞; <i>Figure 12</i>
Short Circuit Current	-100		+100	mA	R _L = Gnd; <i>Figure 15</i>
Power Off Impedance	300			Ohms	V _{CC} = 0V; V _{OUT} = ±2V; <i>Figure 16</i>
AC Characteristics					
Slew Rate					
			30	V/μs	<i>Figure 14</i>
Maximum Transmission Rate	120			kbps	R _L = 3kΩ, C _L = 2500pF
Transition Time					
			1.56	μs	Rise/fall time, between ±3V R _L = 3kΩ, C _L = 2500pF; <i>Figure 17</i>
Propagation Delay					
t _{PHL}		2	8	μs	R _L = 3kΩ, C _L = 2500pF; From 1.5V of T _{IN} to 50% of V _{OUT}
t _{PLH}		2	8	μs	R _L = 3kΩ, C _L = 2500pF; From 1.5V of T _{IN} to 50% of V _{OUT}
RS-232 RECEIVER					
TTL Output Levels					
V _{OL}			0.4	Volts	I _{OUT} = -3.2mA
V _{OH}	2.4			Volts	I _{OUT} = 1.0mA
Receiver Input					
Input Voltage Range					
High Threshold	-15	1.7	+15	Volts	
Low Threshold	0.8	1.2	3.0	Volts	
Hysteresis	0.2	0.5	1	Volts	V _{CC} = 5V; T _A = +25°C
Receiver Input Circuit Bias			+2.0	Volts	<i>Figure 19</i>
Input Impedance	3	5	7	kΩ	V _{IN} = ±15V; <i>Figure 18</i>
AC Characteristics					
Maximum Transmission Rate					
	120			kbps	
Propagation Delay					
t _{PHL}		0.1	1	μs	From 50% of R _{IN} to 1.5V of R _{OUT}
t _{PLH}		0.1	1	μs	From 50% of R _{IN} to 1.5V of R _{OUT}
POWER REQUIREMENTS					
No Load V _{CC} Supply Current					
		40	70	mA	No load; V _{CC} = 5.0V; T _A = 25°C
Full Load V _{CC} Supply Current					
		60	80	mA	RS-232 drivers R _L = 3kΩ to Gnd; DC Input
					V.35 drivers R _L = 100Ω from A to B; DC Input
Shutdown Current		1.5	10	mA	TS000 = ENV35 = 0V

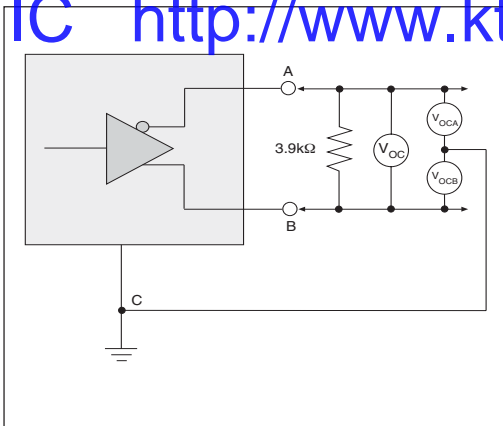

Figure 1. V.11 and V.35 Driver Output Open-Circuit Voltage

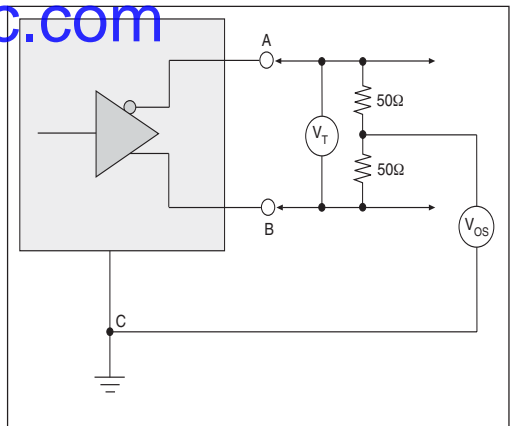

Figure 2. V.35 Driver Output Test Terminated Voltage

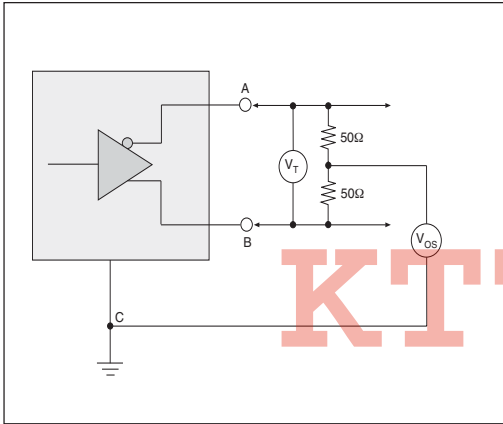

Figure 3. V.35 Driver Output Offset Voltage

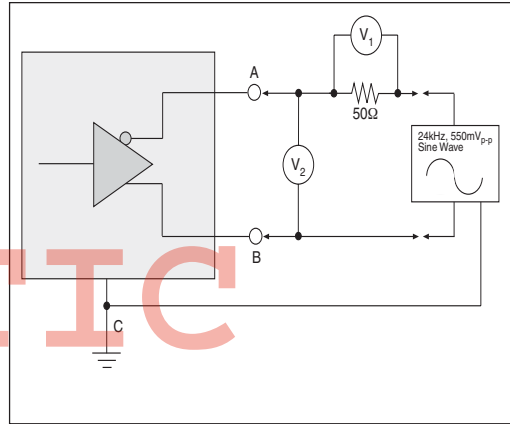

Figure 4. V.35 Driver Output Source Impedance

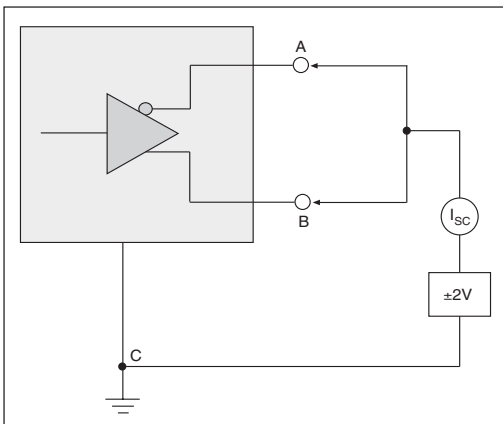

Figure 5. V.35 Driver Output Short-Circuit Impedance

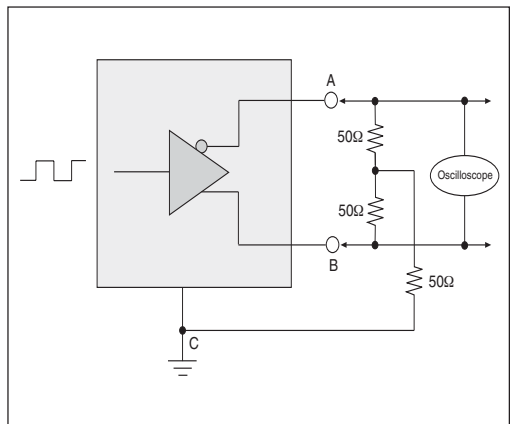

Figure 6. V.35 Driver Output Rise/Fall Time

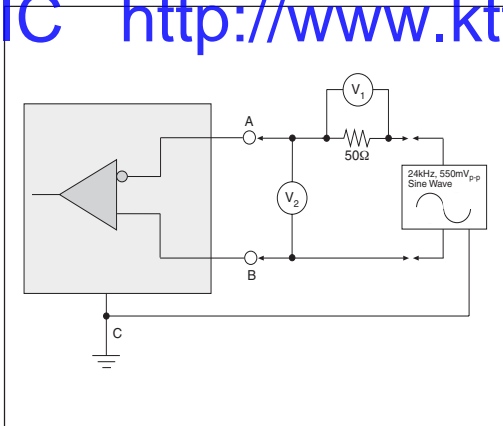

Figure 7. V.35 Receiver Input Source Impedance

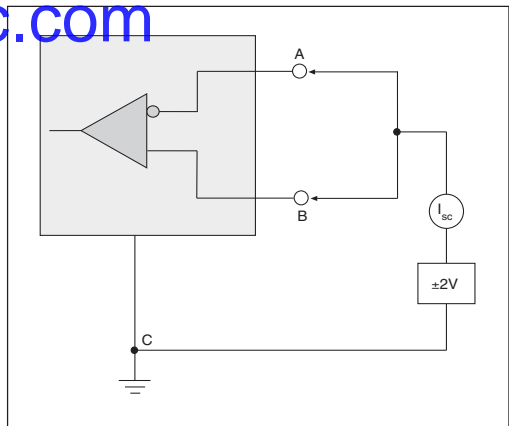

Figure 8. V.35 Receiver Input Short-Circuit Impedance

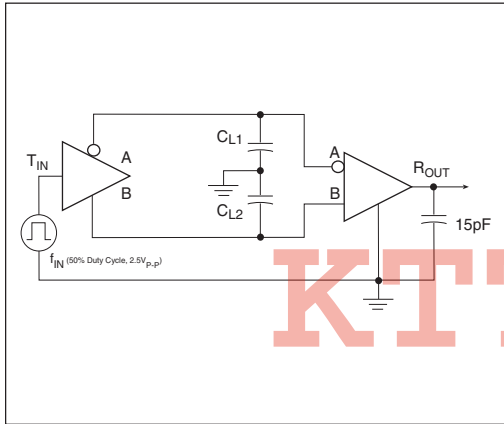

Figure 9. Driver/Receiver Timing Test Circuit

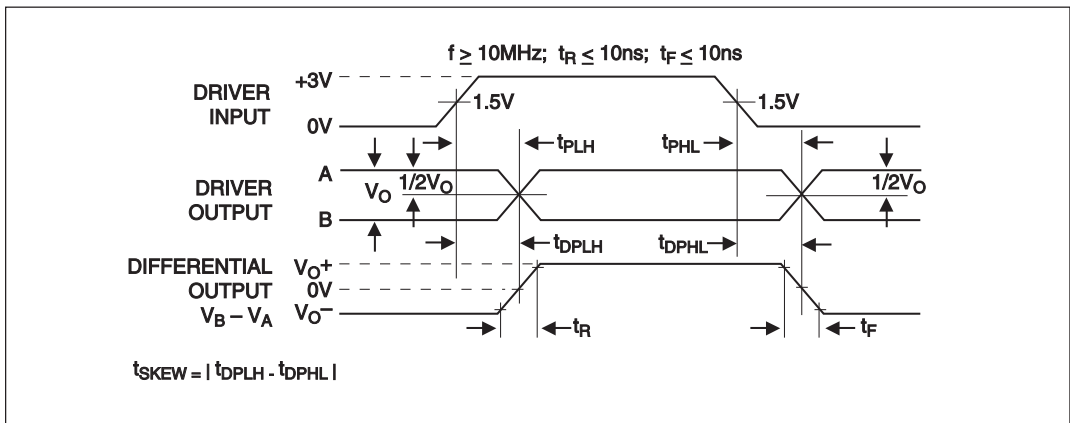

Figure 10. Driver Propagation Delays

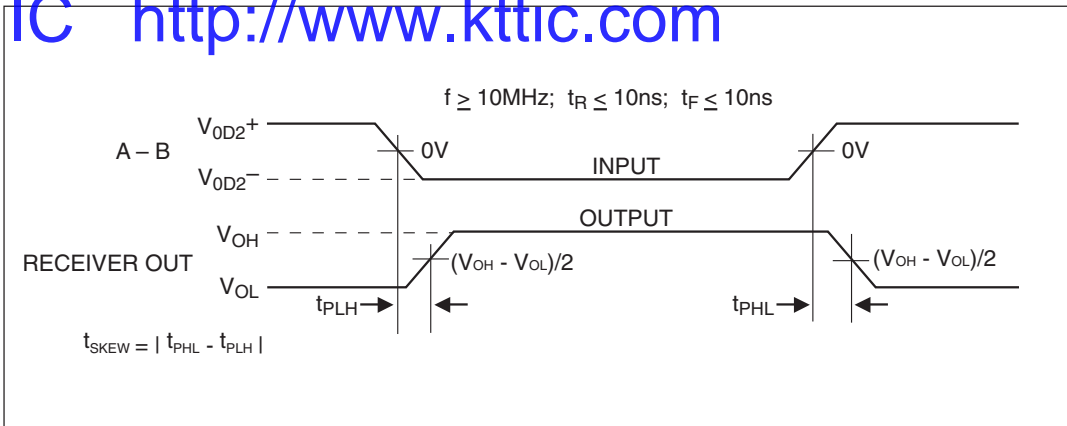

Figure 11. Receiver Propagation Delays

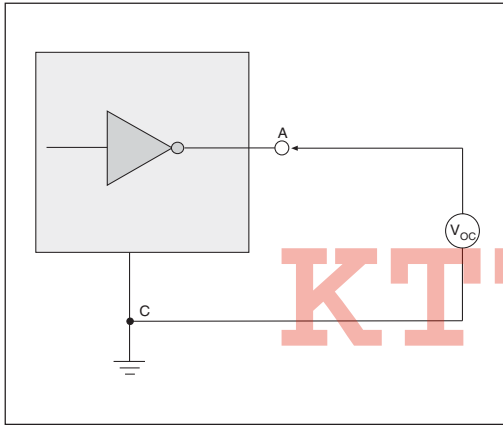

Figure 12. V.28 Driver Output Open Circuit Voltage

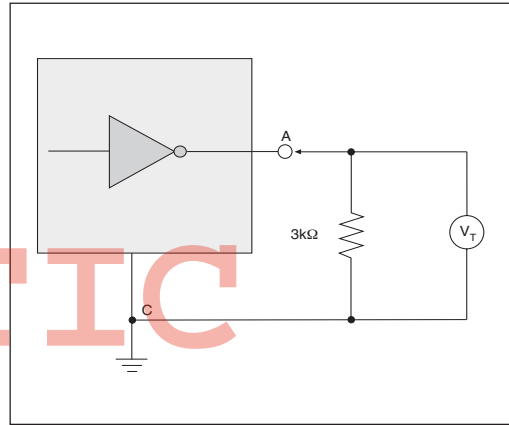

Figure 13. V.28 Driver Output Loaded Voltage

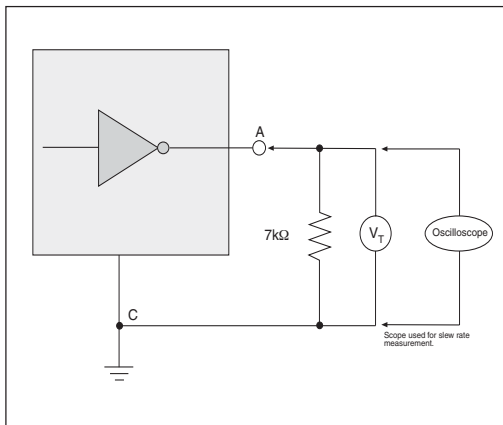

Figure 14. V.28 Driver Output Slew Rate

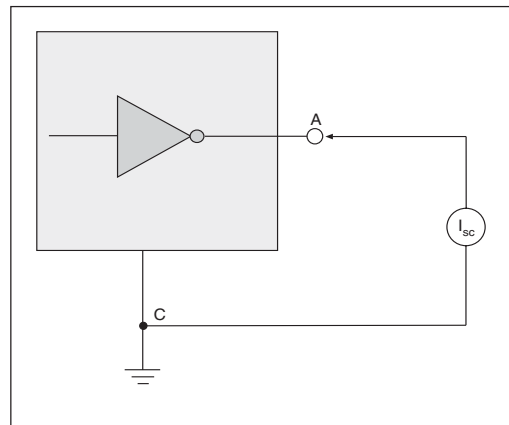

Figure 15. V.28 Driver Output Short-Circuit Current

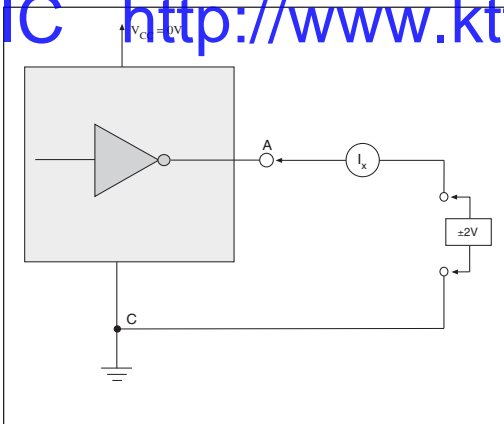

Figure 16. V.28 Driver Output Power-Off Impedance

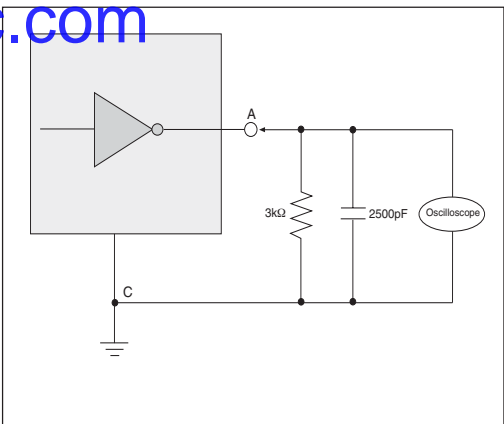

Figure 17. V.28 Driver Output Rise/Fall Times

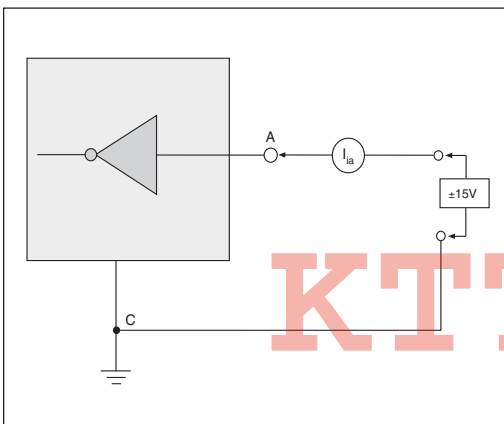

Figure 18. V.28 Receiver Input Impedance

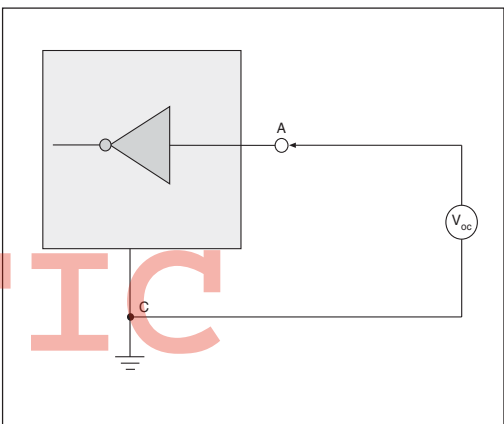

Figure 19. V.28 Receiver Input Open Circuit Bias

THEORY OF OPERATION

The SP319 is a single chip +5V-only serial transceiver that supports all the signals necessary to implement a full V.35 interface. Three V.35 drivers and three V.35 receivers make up the clock and data signals. Four RS-232 (V.28) drivers and four RS-232 (V.28) receivers are used for control line signals for the interface.

V.35 Drivers

The V.35 drivers are +5V-only, low power voltage output transmitters. The drivers do not require any external resistor networks, and will meet the following requirements:

1. Source impedance in the range of 50Ω to 150Ω.
2. Resistance between short-circuited terminals and ground is 150Ω ±15Ω.
3. When terminated with a 100Ω resistive load the terminal to terminal voltage will be 0.55 Volts ±20% so that the A terminal is positive to the B terminal when binary 0 is transmitted, and the conditions are reversed to transmit binary 1.
4. The arithmetic mean of the voltage of the A terminal with respect to ground, and the B terminal with respect to ground will not exceed 0.6 Volts when terminated as in 3 above.

The V.35 drivers can operate at data rates as high as 10Mbps. The driver outputs are protected against short-circuits between the A and B outputs and short circuits to ground.

Two of the V.35 drivers, DRIN2 and DRIN3 are equipped with enable control lines. When the enable pins are high the driver outputs are disabled, the output impedance of a disabled driver will nominally be 300Ω. When the enable pins are low, the drivers are active.

V.35 Receivers

The V.35 receivers are +5V only, low power differential receivers which meet the following requirements:

1. Input impedance in the range of 100Ω ±10Ω.
2. Resistance to ground of 150Ω ±15Ω, measured from short-circuited terminals.

All of the V.35 receivers can operate at data rates as high as 10Mbps. The sensitivity of the V.35 receiver inputs is ±300mV.

RS-232 (V.28) Drivers

The RS-232 drivers are inverting transmitters, which accept either TTL or CMOS inputs and output the RS-232 signals with an inverted sense relative to the input logic levels. Typically, the RS-232 output voltage swing is ±9V with no load, and ±5V minimum with full load. The transmitter outputs are protected against infinite short-circuits to ground without degradation in reliability.

In the power off state, the output impedance of the RS-232 drivers will be greater than 300Ω over a ±2V range. Should the input of a driver be left open, an internal 400kΩ pullup resistor to V_{CC} forces the input high, thus committing the output to a low state. The slew rate of the transmitter output is internally limited to a maximum of 30V/μs in order to meet the EIA standards. The RS-232 drivers are rated for 120kbps data rates.

RS-232 (V.28) Receivers

The RS-232 receivers convert RS-232 input signals to inverted TTL signals. Each of the four receivers features 500mV of hysteresis margin to minimize the effects of noisy transmission lines. The inputs also have a 5kΩ resistor to ground; in an open circuit situation the input of the receiver will be forced low, committing the output to a logic high state. The input resistance will maintain 3kΩ-7kΩ over a ±15V range. The maximum operating voltage range for the receiver is ±30V, under these conditions the input current to the receiver must be limited to less than 100mA. The RS-232 receivers can operate to beyond 120kbps.

CHARGE PUMP

The charge pump is a Sipex patented design (U.S. 5,306,954) that uses an innovative approach. The charge pump, with four external capacitors, uses a four-phase voltage shifting technique to attain a symmetrical ±10V power supply. The capacitors can be as low as 0.1μF with a 16 Volt rating. Either polarized or non-polarized capacitors can be used.

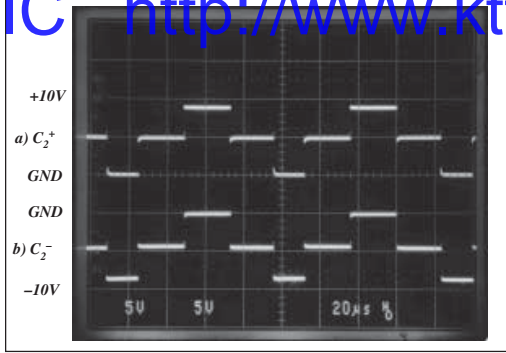

Figure 20. Charge Pump Waveforms

Figure 20 shows the waveforms on the positive and negative sides of capacitor C2 respectively. A free-running oscillator controls the four phases of the voltage shifting. A description of each phase follows.

Phase 1: V_{SS} Charge Storage (Figure 21)

During this phase of the clock cycle, the positive side of capacitors C1 and C2 are charged to +5V. C1+ is switched to ground and the charge on C1- is transferred to C2-. Since C2+ is connected to +5V, the voltage potential across capacitor C2 becomes 10V.

Phase 2: V_{SS} Transfer (Figure 22)

Phase two of the clock connects the negative terminal of C2 to the V_{SS} storage capacitor and the positive terminal of C2 to ground, and transfers the generated -10V to C3. Simultaneously, the positive side of capacitor C1 is switched to +5V and the negative side is connected to ground.

Phase 3: V_{DD} Charge Storage (Figure 23)

The third phase of the clock is identical to the first phase - the transferred charge on C1 produces -5V on the negative terminal of C1, which is applied to the negative side of capacitor C2. Since C2+ is at +5V, the voltage potential across C2 is +10V.

Phase 4: V_{DD} Transfer (Figure 24)

The fourth phase of the clock connects the negative terminal of C2 to ground and transfers the generated +10V across C2 to C4, the V_{DD} storage capacitor. The positive side of capacitor C1 is switched to +5V and the negative side is connected to ground, and the cycle begins again.

Since both V_{+} and V_{-} are separately generated from V_{CC} in a no load condition, V_{+} and V_{-} will be symmetrical. Older charge pump approaches that generate V_{-} from V_{+} will show a decrease in the magnitude of V_{-} compared to V_{+} due to the inherent inefficiencies in design.

The clock rate for the charge pump typically operates at 15kHz with 0.1 μ F, 16V external capacitors.

Shutdown Mode

The SP319 can be put into a low power shutdown mode by bringing both TS000 (pin 3) and ENV35 (pin 9) low. In shutdown mode, SP319 draws less than 2mA. For normal operation, both pins should be connected to +5V.

Termination Enable

The SP319 includes a termination enable pin that connects or disconnects the receiver input termination circuitry. A TTL logic LOW at \overline{ENT} (pin 75) will connect the "Y" termination network to the V.35 receiver inputs. A TTL logic HIGH at \overline{ENT} (pin 75) will disconnect the "Y" termination network and the receivers will operate as V.11 compliant receivers. The \overline{ENT} pin has an internal pull-down resistor so that a floating input will enable the termination network. The SP319 is compatible with the SP320 since pin 75 on the SP320 is designated as a no connect.

External Power Supplies

For applications where separate external supplies can be applied at the V_{+} and V_{-} pins. The value of the external supply voltages should not exceed $\pm 10V$. It is critical the external power supplies provide a power supply sequence of : +10V, +5V, and then -10V.

Applications Information

The SP319 is a single chip device that can implement a complete V.35 interface. Three (3) V.35 drivers and three (3) V.35 receivers are used for clock and data signals and four (4) RS-232 (V.28) drivers and four (4) RS-232 (V.28) receivers can be used for the control signals of the interface. Figures 25 to 28 show the SP319 configured in DTE and DCE applications along with an ISO-2593 pin out.

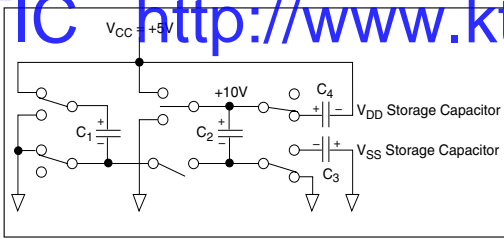

Figure 21. Charge Pump Phase 1

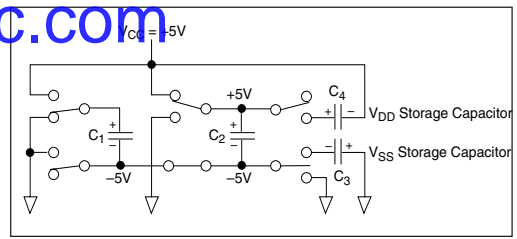

Figure 22. Charge Pump Phase 2

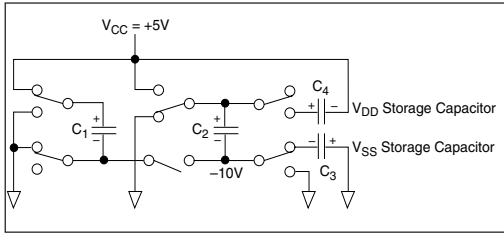

Figure 23. Charge Pump Phase 3

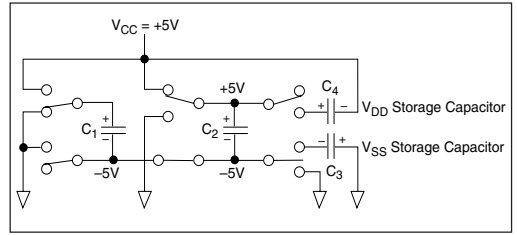

Figure 24. Charge Pump Phase 4

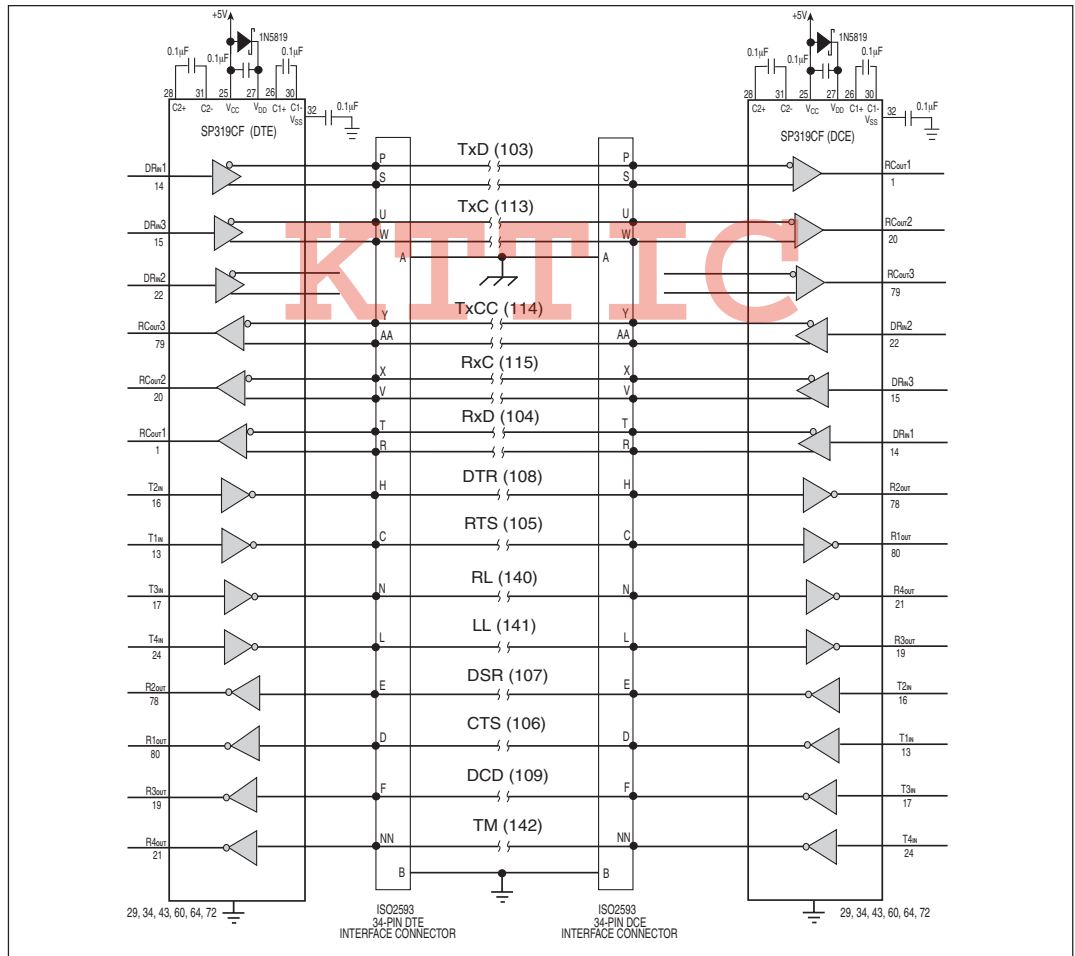

Figure 25. Typical DTE-DCE V.35 Connection using the SP319

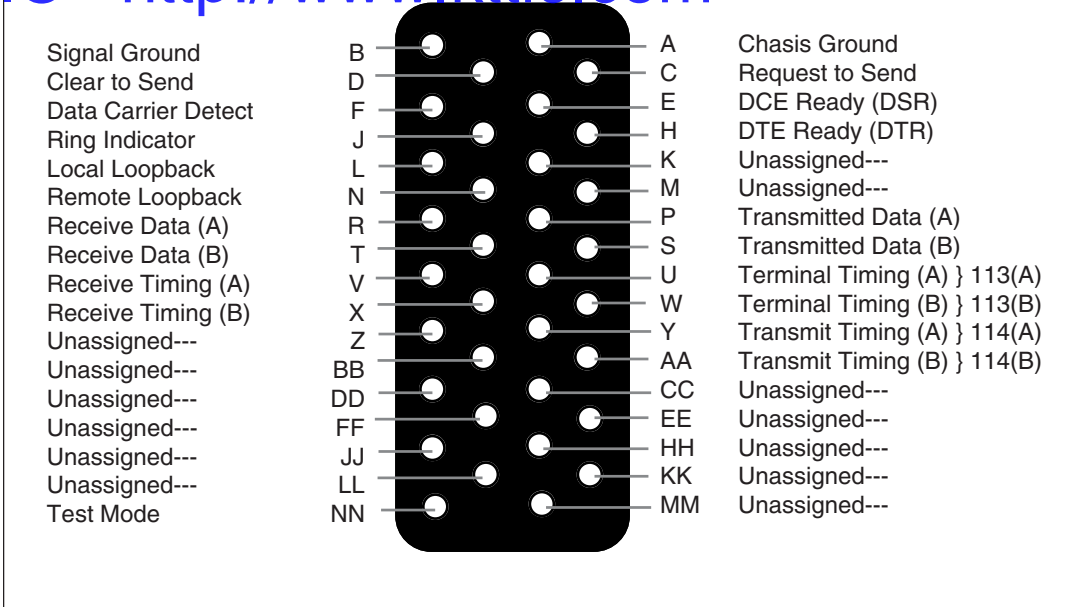

Figure 26. ISO-2593 Connector Pin Out

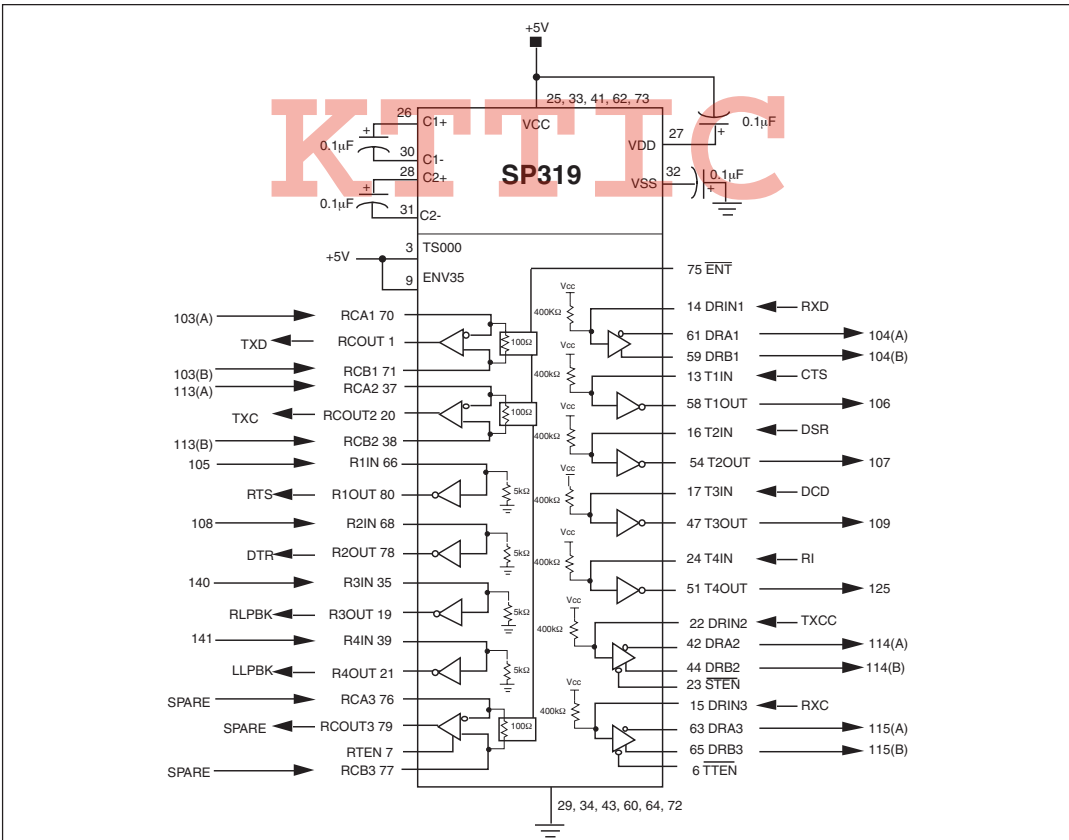

Figure 27. Typical DCE V.35 Interface

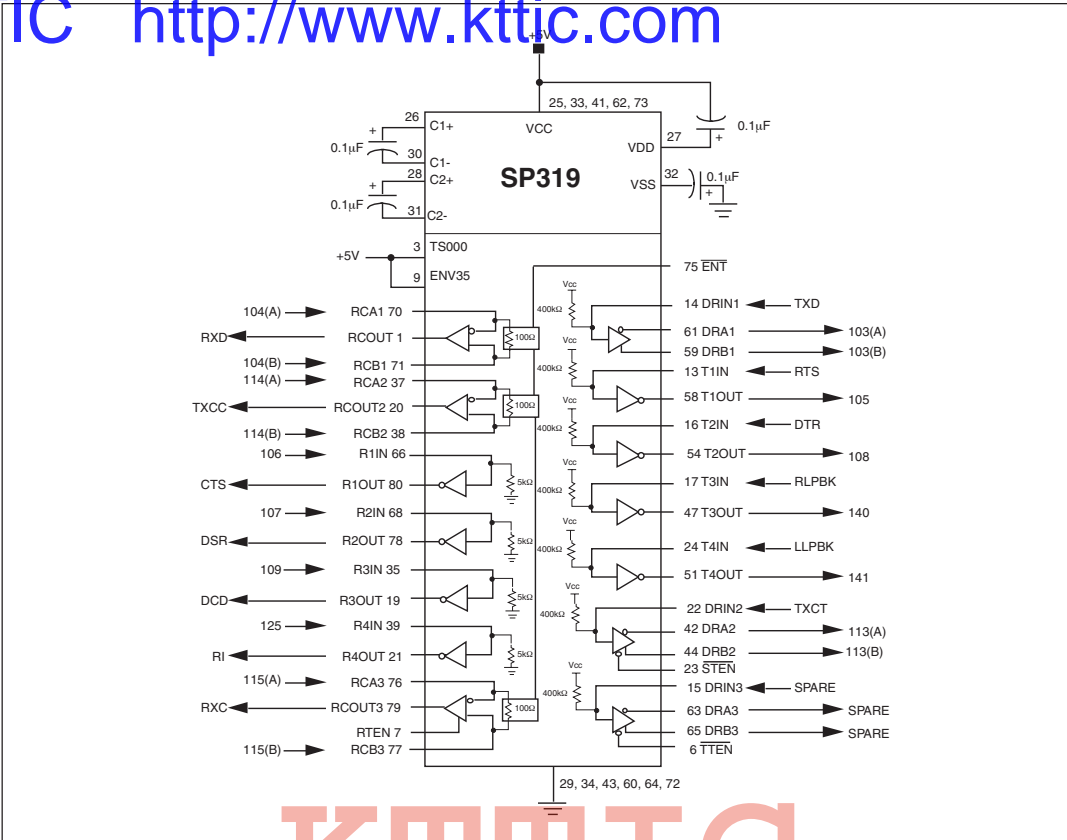
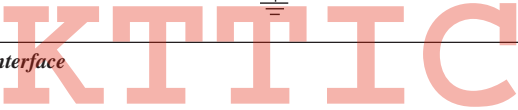
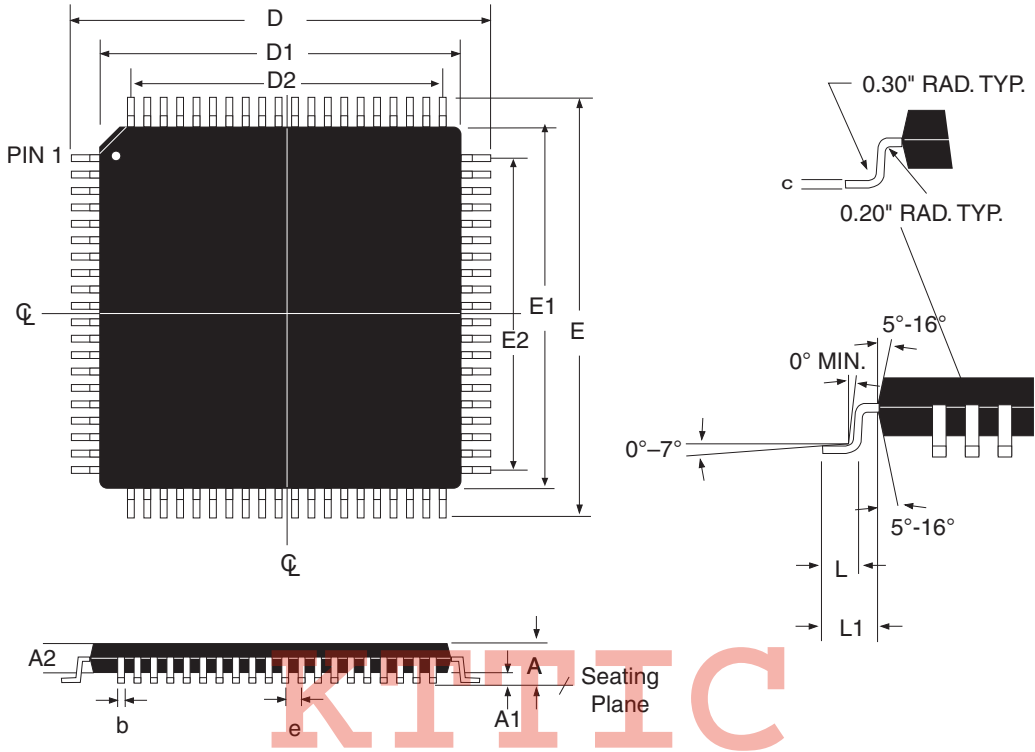

Figure 28. Typical DTE V.35 Interface



PACKAGE: 80-PIN MQFP



DIMENSIONS Minimum/Maximum (mm)	80-PIN MQFP JEDEC MS-22 (BEC) Variation		
	MIN	NOM	MAX
A			2.45
A1	0.00		0.25
A2	1.80	2.00	2.20
b	0.22		0.40
D	17.20 BSC		
D1	14.00 BSC		
D2	12.35 REF		
E	17.20 BSC		
E1	14.00 BSC		
E2	12.35 REF		
e	0.65 BSC		
N	80		

COMMON DIMENTIONS			
SYMBL	MIN	NOM	MAX
c	0.11		23.00
L	0.73	0.88	1.03
L1	1.60 BASIC		

80 PIN MQFP (MS-022 BC)

ORDERING INFORMATION

Model	Temperature Range	Package Types
.....	0°C to +70°C	80-pin JEDEC MQFP

Please consult the factory for pricing and availability on a Tape-On-Reel option.

Available in lead free packaging. To order add "-L" suffix to part number.
 Example: SP319CF = standard; SP319CF-L/TR = lead free.

REVISION HISTORY

DATE	REVISION	DESCRIPTION
1/27/04	A	Implemented tracking revision.
6/8/05	B	Added Lead Free information for ordering.
6/12/05	C	Fixed typo on figure 25 DCE RCout1.
1/18/06	C	SP319CF is being obsoleted per PCN 06-0117-01.



ANALOG EXCELLENCE

Sipex Corporation

Headquarters and Sales Office
 22 Linnell Circle
 Billerica, MA 01821
 TEL: (978) 667-8700
 FAX: (978) 670-9001
 e-mail: sales@sipex.com

Sales Office
 233 South Hillview Drive
 Milpitas, CA 95035
 TEL: (408) 934-7500
 FAX: (408) 935-7600

Sipex Corporation reserves the right to make changes to any products described herein. Sipex does not assume any liability arising out of the application or use of any product or circuit described herein; neither does it convey any license under its patent rights nor the rights of others.