



EUTECH
MICROELECTRONICS

300mA Low-Noise Low-Dropout Linear Regulator

DESCRIPTION

The EUP7967A low-noise, low-dropout, linear regulator operates from a 2.5V to 5.5V input and is guaranteed to deliver 300mA.

The EUP7967A is stable with small 2.2 μ F ceramic capacitor. Its performance suits battery powered applications because of its shutdown mode, low quiescent current, and very low dropout voltage. The low dropout voltage allows for more utilization of a battery's available energy by operating closer to its end-of-life voltage.

The EUP7967A is available in 1.2V, 1.5V, 1.8V, 2.5V, 2.8V, 3V, 3.3V and Adjustable versions.

FEATURE

- 300mA Guaranteed Output Current
- 65dB PSRR at 1kHz
- Low Noise Output
- 150mV Dropout at 300mA Load
- Low 84 μ A No-Load Supply Current
- $\leq 1\mu$ A Shutdown Current
- Stable With 2.2 μ F Ceramic Output Capacitors
- Thermal Shutdown and Short-Circuit Protection
- SOT23-5 Package
- RoHS Compliant and 100% Lead (Pb)-Free

APPLICATIONS

- Wireless Handsets
- DSP Core Power
- Battery Powered Electronics
- Portable Information Appliance

Block Diagram

KTTIC

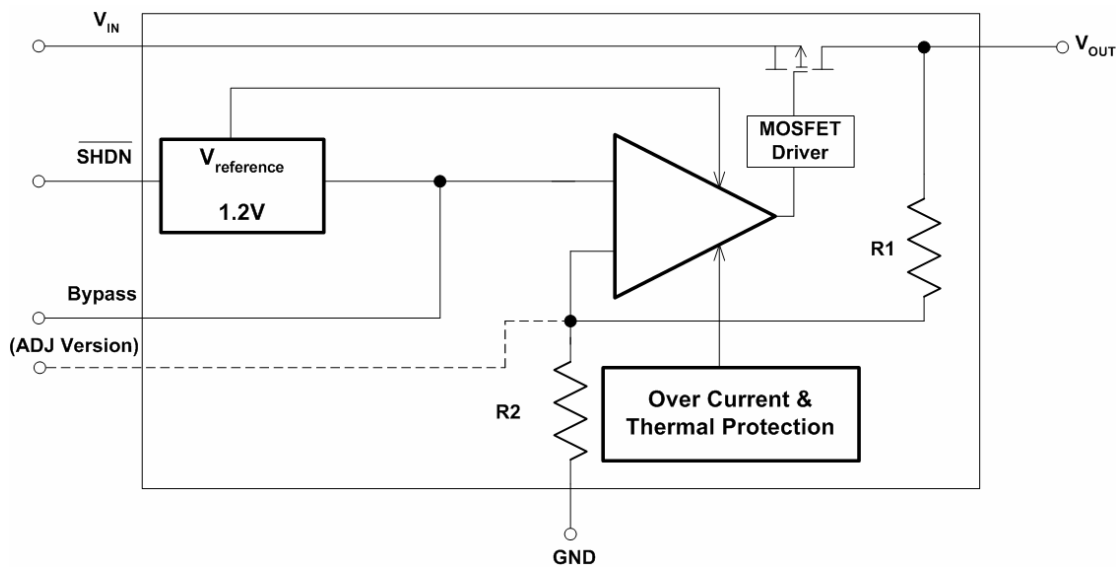

Figure1.

Typical Application Circuit

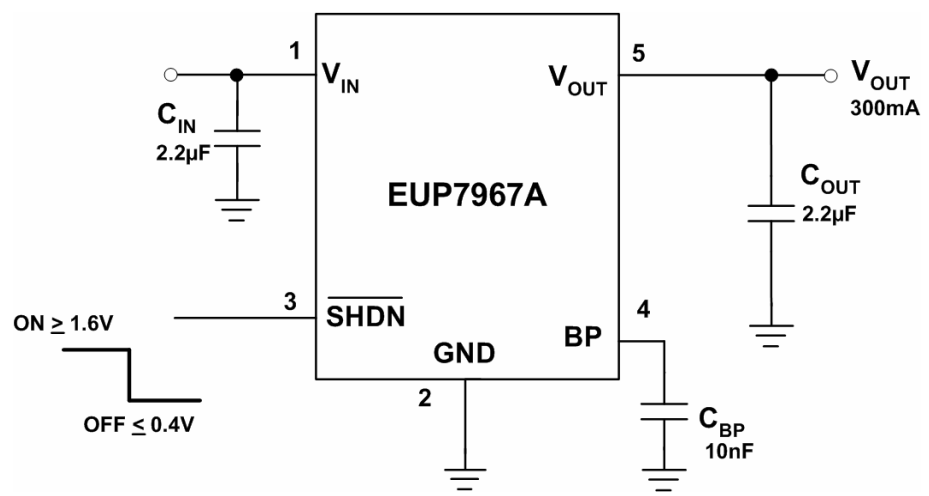

Figure2. Fixed-Voltage LDO Regulator

Pin Configurations

Package Type	Pin Configurations
SOT23-5	<div style="display: flex; justify-content: space-around; align-items: flex-start;"> <div style="text-align: center;"> <p>Fixed-Voltage</p> </div> <div style="text-align: center;"> <p>Adjustable Voltage</p> </div> </div>

Pin Description

PIN	NAME	DESCRIPTION
1	V _{IN}	Input voltage of the LDO
2	GND	Common Ground
3	SHDN	SHDN places the entire device in shutdown mode when held low
4	BP	Compensation capacitor for noise reduction
	ADJ	Adjustable regulator feedback input. Connect to resistor divider.
5	V _{OUT}	Output voltage of the LDO

Ordering Information

Order Number	Package Type	Marking	Operating Temperature Range
EUP7967A-12VIR1	SOT23-5	hT	-40°C to 85°C
EUP7967A-15VIR1	SOT23-5	h0	-40°C to 85°C
EUP7967A-18VIR1	SOT23-5	h1	-40°C to 85°C
EUP7967A-25VIR1	SOT23-5	h2	-40°C to 85°C
EUP7967A-28VIR1	SOT23-5	h6	-40°C to 85°C
EUP7967A-30VIR1	SOT23-5	h5	-40°C to 85°C
EUP7967A-33VIR1	SOT23-5	h3	-40°C to 85°C
EUP7967AVIR1	SOT23-5	hA	-40°C to 85°C

EUP7967A

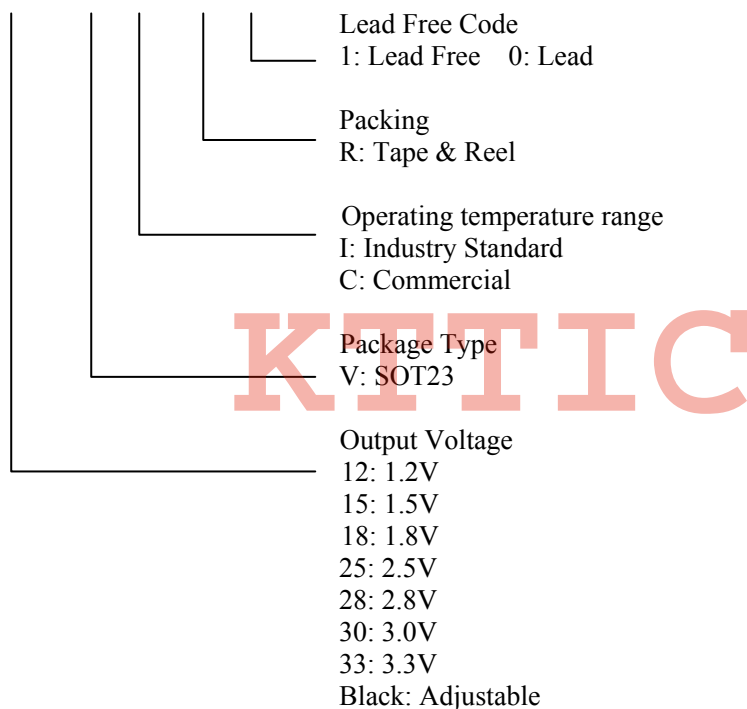

Absolute Maximum Ratings

- V_{IN}, V_{EN} ----- -0.3 to 6V
- V_{OUT} ----- -0.3 to $(V_{IN}+0.3) \leq 6V$
- Junction Temperature ----- 150°C
- Storage Temperature ----- -65°C to +150°C
- Lead Temp ----- 235°C
- Pad Temp ----- 235°C
- Maximum Power Dissipation SOT23-5 ----- 364mW
- Thermal Resistance $\theta_{JA}(SOT23-5)$ ----- 220°C/W
- ESD Rating
 Human Body Model ----- 2kV

Operating Ratings

- V_{IN} ----- 2.5 to 5.5V
- V_{EN} ----- 0 to $(V_{IN}+0.3) \leq 5.5V$
- Junction Temperature ----- -40°C to +125°C

Electrical Characteristics

Unless otherwise specified, all limits guaranteed for $V_{IN}=V_O+0.5V$, $\overline{V_{SHDN}}=V_{IN}$, $C_{IN}=C_{OUT}=2.2\mu F$, $C_{BP}=10nF$, $T_A=25^\circ C$.

Symbol	Parameter	Conditions	EUP7967A			Unit
			Min	Typ	Max.	
ΔV_O	Output Voltage Tolerance	$100\mu A \leq I_{OUT} \leq 300mA$ $V_{IN}=V_O+0.5V$	-3		+3	% of $V_{OUT(NOM)}$
I_O	Maximum Output Current	Continuous	300			mA
I_{LIMIT}	Output Current Limit	$T_A = -40^\circ C$ to $85^\circ C$	350	720		mA
I_Q	Supply Current	$I_{OUT}=0mA$		84	140	μA
	Shutdown Supply Current	$V_O=0V$, $\overline{SHDN}=GND$			1	μA
V_{DO}	Dropout Voltage	$I_{OUT}=300mA$		150	200	mV
ΔV_O	Line Regulation	$I_{OUT}=1mA$, $(V_O+0.5V) \leq V_I \leq 5.5V$		0.05	0.2	%/V
	Load Regulation	$1mA \leq I_{OUT} \leq 300mA$		15	35	mV
e_n	Output Voltage Noise	$I_{OUT}=10mA$, $10Hz \leq f \leq 100kHz$		50		μV_{RMS}
$\overline{V_{SHDN}}$	SHDN Input Threshold	$V_{IH}, (V_O+0.5V) \leq V_I \leq 5.5V$	1.6			V
		$V_{IL}, (V_O+0.5V) \leq V_I \leq 5.5V$			0.4	
$\overline{I_{SHDN}}$	SHDN Input Bias Current	$\overline{SHDN}=GND$ or IN		0.1	100	nA
	FB Input Bias Current (ADJ Version)	$V_{IN}=5.5V$, $V_{FB}=1.3V$		1		nA
V_{FB}	FB Pin Voltage (ADJ Version)	$T_A=25$	1.176	1.2	1.224	V
T_{SD}	Thermal Shutdown Temperature			160		°C
	Thermal Shutdown Hysteresis			20		
PSRR	Power Supply Rejection Ratio	$V_{IN}=V_{OUT}+1V$, $f=1kHz$		65		dB

Typical Operating Characteristics

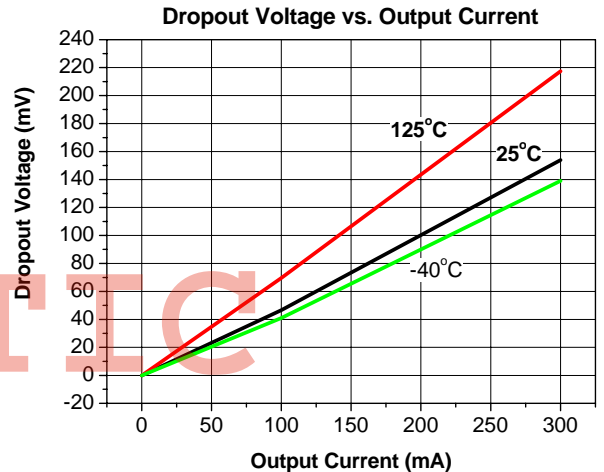
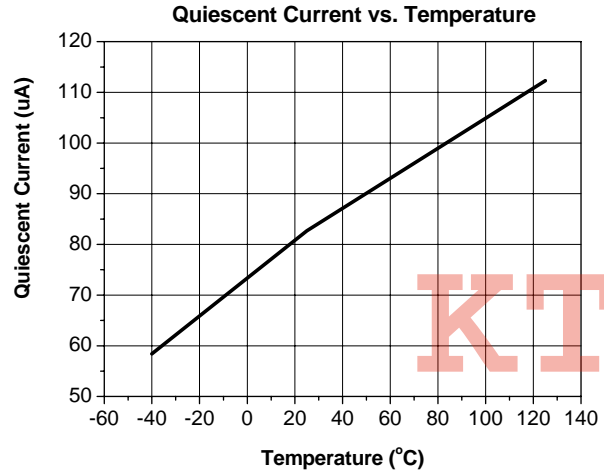
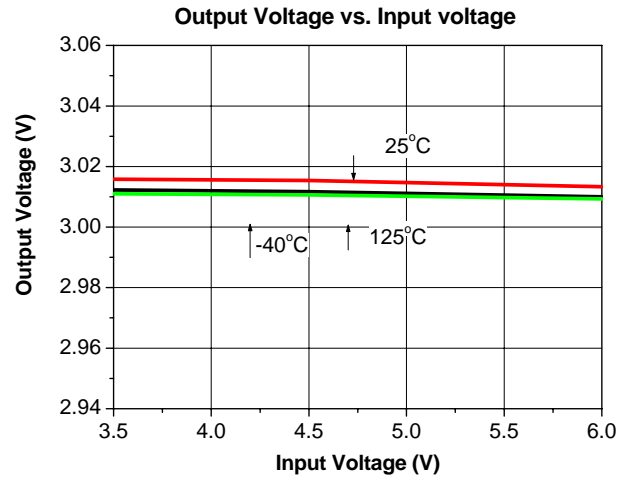
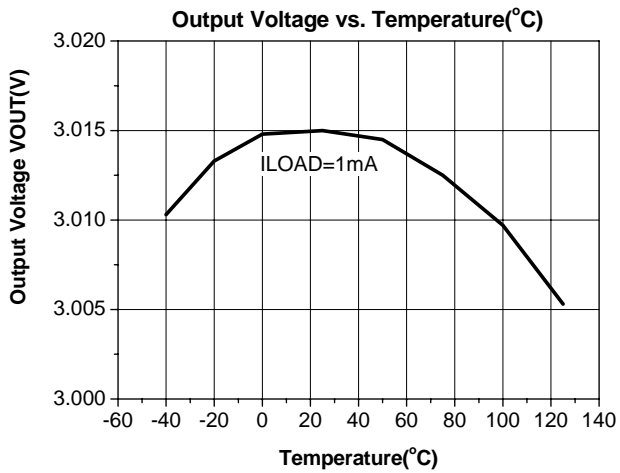

Line Transient Response (I_{Load}=1mA to 150mA)

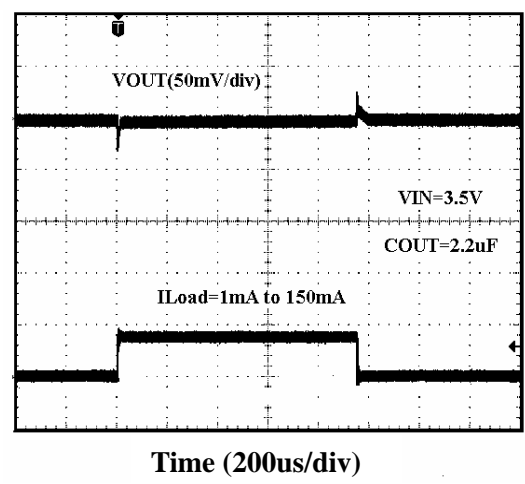

Line Transient Response (I_{Load}=1mA to 300mA)

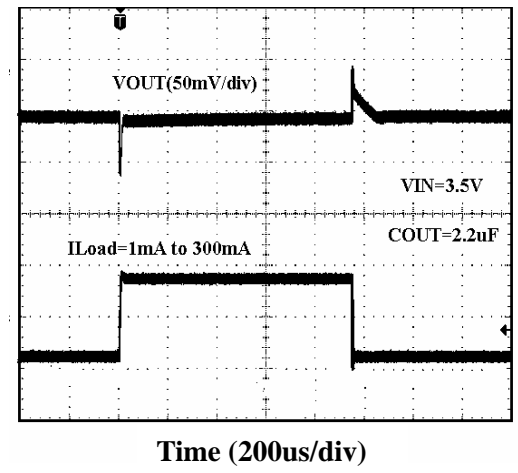

Line Transient Response (CO_{UT}=1 μ F)

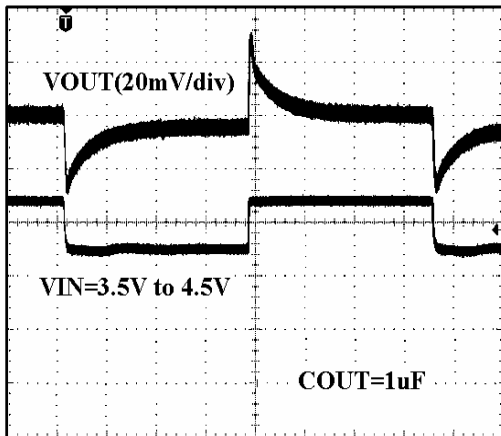

Time (200 μ s/div)

Line Transient Response (CO_{UT}=2.2 μ F)

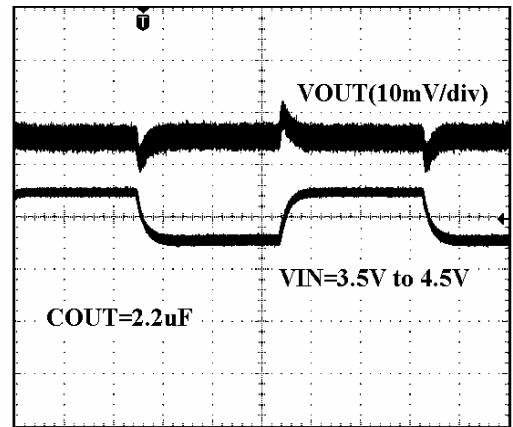

Time (200 μ s/div)

PSRR

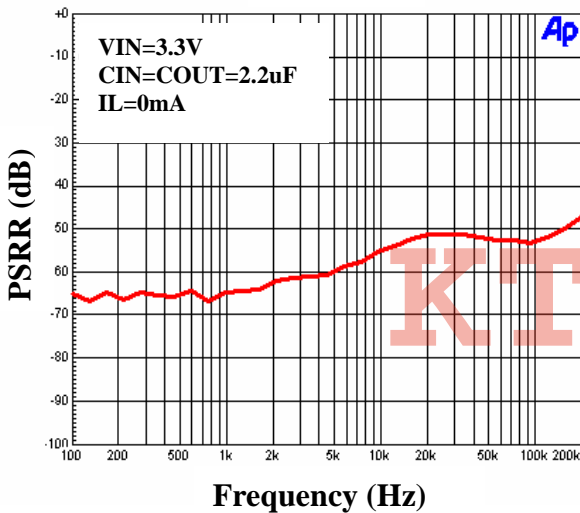

Start Up

Output1 Noise (10Hz to 100KHz)

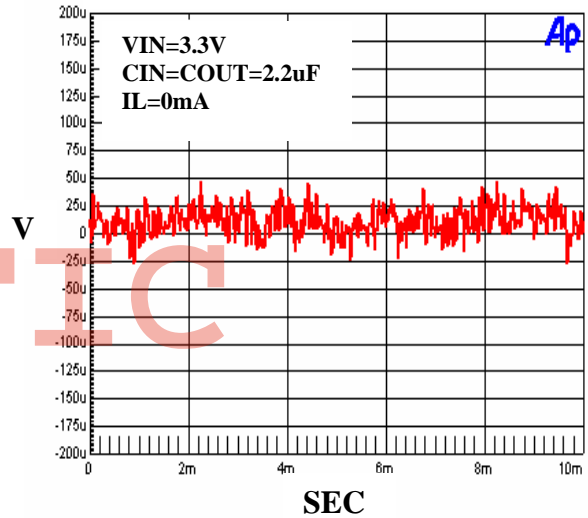

Start Up

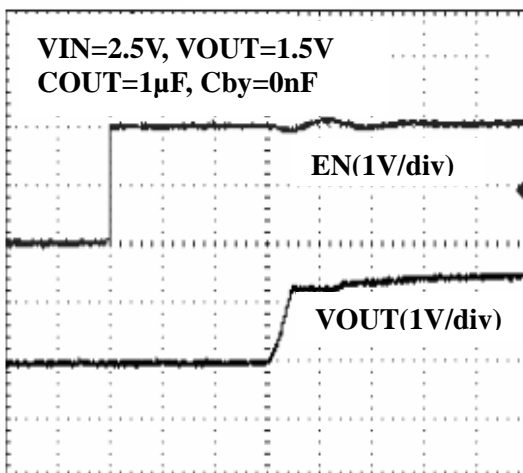

Time (5 μ s/div)

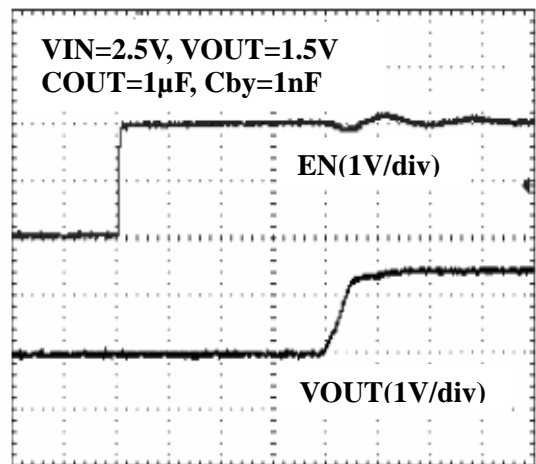

Time (5 μ s/div)

Start Up

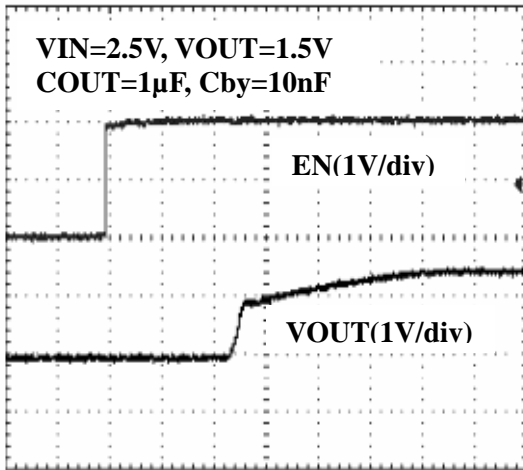

Time (25us/div)

Start Up

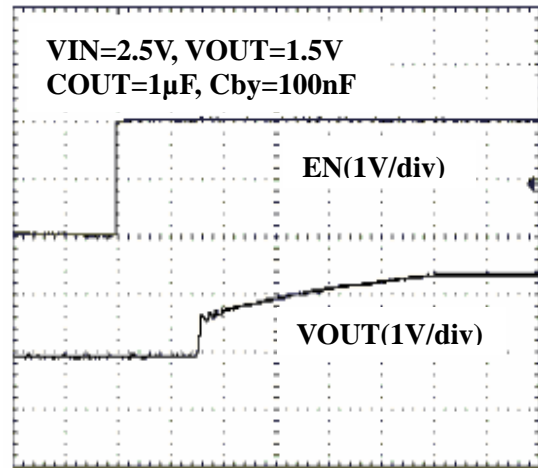

Time (250us/div)

KTTIC

Application Information**External Capacitors**

Like any low-dropout regulator, the EUP7967A requires external capacitors for regulator stability. The EUP7967A is specifically designed for portable applications requiring minimum board space and smallest components. These capacitors must be correctly selected for good performance.

Input Capacitor

A minimum input capacitance of 1 μ F is required between the EUP7967A input pin and ground (the amount of the capacitance may be increased without limit). This capacitor must be located a distance of not more than 1cm from the input pin and returned to a clean analog ground.

Any good quality ceramic, tantalum, or film capacitor may be used at the input. If a tantalum capacitor is used at the input, it must be guaranteed by the manufacturer to have a surge current rating sufficient for the application.

No-Load Stability

The EUP7967A will remain stable and in regulation with no external load. This is specially important in CMOS RAM keep-alive applications.

Output Capacitance

The EUP7967A is specifically designed to employ ceramic output capacitors as low as 2.2 μ F. Ceramic capacitors below 10 μ F offer significant cost and space savings, along with high frequency noise filtering. Higher values and other types and of capacitor may be used, but their equivalent series resistance (ESR) should be maintained below 0.5 Ω . Ceramic capacitor of the value required by the EUP7967A are available in the following dielectric types: Z5U, Y5V, X5R, and X7R. The Z5U and Y5V types exhibit a 50% or more drop in capacitance value as their temperature increase from 25 $^{\circ}$ C, an important consideration. The X5R generally maintain their capacitance value within \pm 20%. The X7R type are desirable for their tighter tolerance of 10% over temperature.

Noise Bypass Capacitor

An external 10nF bypass capacitor at BP pin conjunction with an internal resistor creates lowpass filter. Increasing the capacitance will decrease the output noise. This cap is connected directly to a high impedance node in the bandgap reference circuit. Any significant loading on this node will cause a change on the regulated output voltage. For this reason, DC leakage current through this pin must be kept as low as possible for best output voltage accuracy. The types of capacitors best suited for the noise bypass capacitor are ceramic and film.

Unlike many other LDO's, addition of a noise reduction capacitor does not effect the load transient response of the device. However, it does affect start-up time. The smaller the capacitance value, the quicker the start-up time.

Power Dissipation and Junction Temperature

Specified regulator operation is assured to a junction temperature of 125 $^{\circ}$ C; the maximum junction temperature should be restricted to 125 $^{\circ}$ C under normal operating conditions. This restriction limits the power dissipation the regulator can handle in any given application. To ensure the junction temperature is within acceptable limits, calculate the maximum allowable dissipation, $P_{D(max)}$, and the actual dissipation, P_D , which must be less than or equal to $P_{D(max)}$.

The maximum-power-dissipation limit is determined using the following equation:

$$P_{D(max)} = \frac{T_{Jmax} - T_A}{R_{\theta JA}}$$

Where:

T_{JMAX} is the maximum allowable junction temperature.

$R_{\theta JA}$ is the thermal resistance junction-to-ambient for the package

T_A is the ambient temperature.

The regulator dissipation is calculated using:

$$P_D = (V_I - V_O) \times I_O$$

Power dissipation resulting from quiescent current is negligible. Excessive power dissipation triggers the thermal protection circuit.

Shutdown

The EUP7967A goes into sleep mode when the $\overline{\text{SHDN}}$ pin is in a logic low condition. During this condition, the pass transistor, error amplifier, and bandgap are turned off, reducing the supply current to 60nA typical. The $\overline{\text{SHDN}}$ pin may be directly tied to V_{IN} to keep the part on.

Adjustable Operation

The adjustable version of the EUP7967A has an output voltage range of 1.2V to 4.5V. The output voltage of the EUP7967A adjustable regulator is programmed using an external resistor divider as shown in Figure3. The output voltage is calculated using:

$$V_O = V_{ref} \times \left(1 + \frac{R_1}{R_2}\right)$$

Where:

Vref= 1.2V typ. (the internal reference voltage)

Utilize the following equation for adjusting the output to a particular voltage:

$$R_1 = R_2 \left[\frac{V_O}{1.2V} - 1 \right]$$

Choose R2=50k to optimize accuracy, power supply rejection, noise and power consumption.

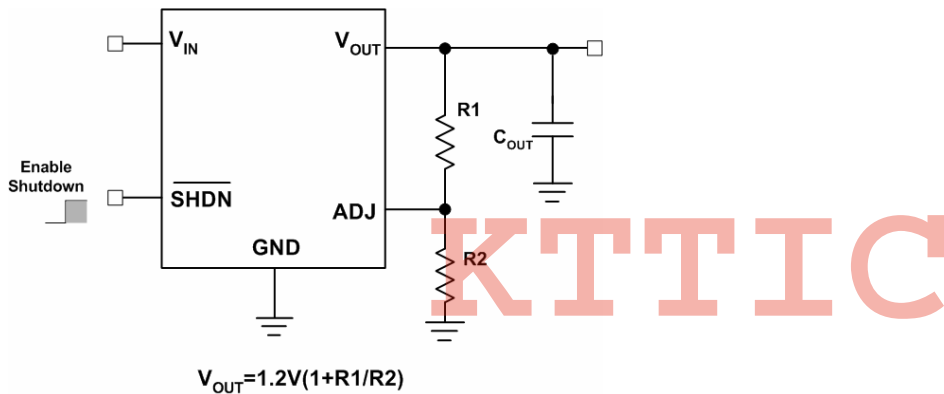
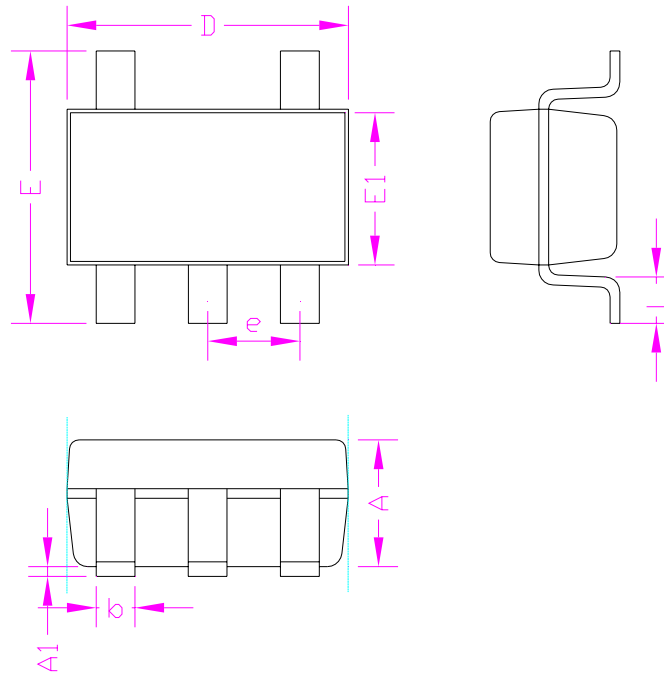

Figure3. Adjustable Regulator with Resistors

Packaging Information

SOT23-5



KTTIC

SYMBOLS	MILLIMETERS		INCHES	
	MIN.	MAX.	MIN.	MAX.
A	-	1.30	-	0.052
A1	0.00	0.15	0.000	0.006
D	2.90		0.114	
E1	1.60		0.063	
E	2.60	3.00	0.102	0.118
L	0.30	0.60	0.012	0.024
b	0.30	0.50	0.012	0.020
e	0.95		0.037	