



# 1.5MHz, 600mA Synchronous Step-Down Converter

## DESCRIPTION

The EUP3406 is a constant frequency, current mode, PWM step-down converter. The device integrates a main switch and a synchronous rectifier for high efficiency. The 2.5V to 5.5V input voltage range makes the EUP3406 ideal for powering portable equipment that runs from a single cell Lithium-Ion (Li+) battery or 3-cell NiMH/ NiCd batteries. The output voltage can be regulated as low as 0.6V. The EUP3406 supports up to 600mA load current and can also run at 100% duty cycle for low dropout applications, extending battery life in portable systems.

Switching frequency is internally set at 1.5MHz, allowing the use of small surface mount inductor and capacitors. The internal synchronous switch increases efficiency while eliminate the need for an external Schottky diode. The EUP3406 is available in a low profile 5 lead SOT package.

## FEATURES

- High Efficiency
- 1.5MHz Constant Switching Frequency
- 600mA Available Load Current
- 270µA Typical Quiescent Current
- 2.5V to 5.5V Input Voltage Range
- Adjustable Output Voltage as Low as 0.6V
- 100% Duty Cycle Low Dropout Operation
- No Schottky Diode Required
- Short Circuit and Thermal Protection
- Over Voltage Protection
- < 1µA Shutdown Current
- Available in SOT23-5 Package
- RoHS Compliant and 100% Lead(Pb)-Free

## APPLICATIONS

- Cellular and Smart Phones
- Portable Media Players/ MP3 Players
- Digital Still and Video Cameras
- Portable Instruments
- WLAN PC Cards

## Typical Application Circuit

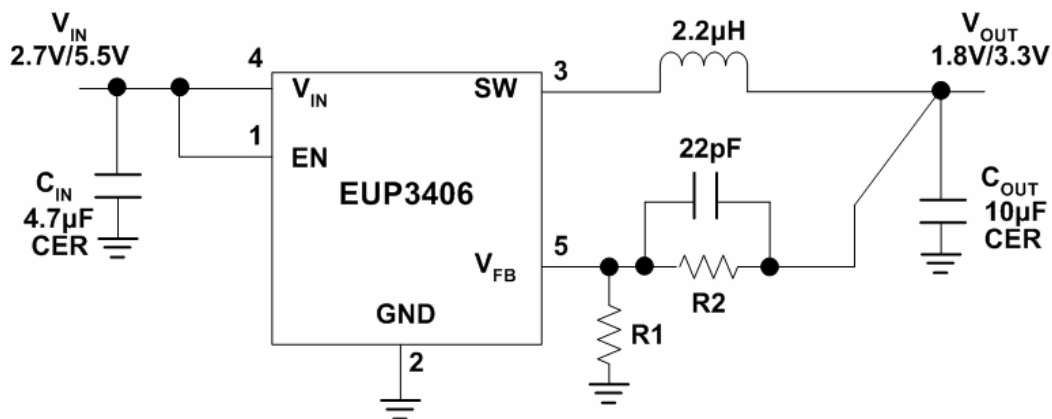

Figure1.

**Block Diagram**

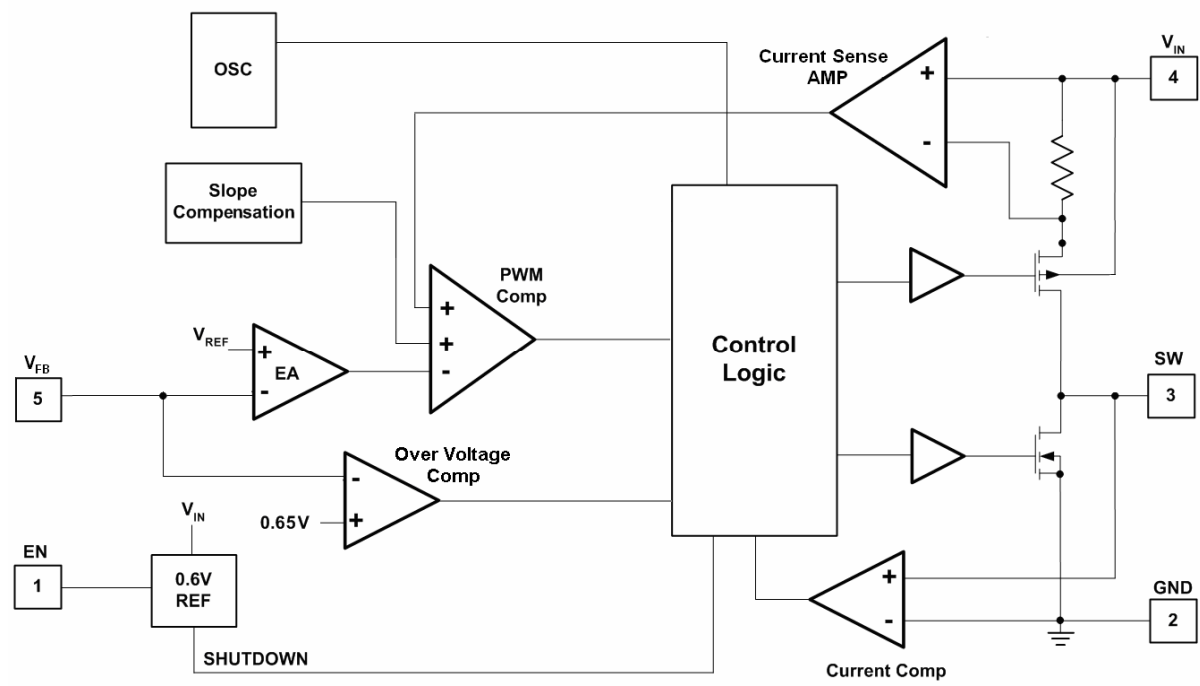

Figure2.

**Pin Configurations**

Package Type	Pin Configurations
SOT23-5	<p>The diagram shows a top-down view of the SOT23-5 package. Pin 1 (EN) is at the top right, pin 2 (GND) is at the top center, pin 3 (SW) is at the top left, pin 4 (VIN) is at the bottom left, and pin 5 (VFB) is at the bottom right. A dot is present on pin 1.</p>

**Pin Description**

PIN	Pin	DESCRIPTION
EN	1	Chip Enable pin. Forcing this pin above 1.5V enables the part. Forcing this pin below 0.3V shuts down the device. Do not leave EN floating.
GND	2	Common ground
SW	3	Switch Node Connection to Inductor. This pin connects to the drains of the internal main and synchronous power MOSFET switches.
$V_{IN}$	4	Supply voltage pin
$V_{FB}$	5	Feedback pin

**Ordering Information**

Order Number	Package Type	Marking	Operating Temperature range
EUP3406VIR1	SOT23-5	e A	-40 °C to 85°C

EUP3406

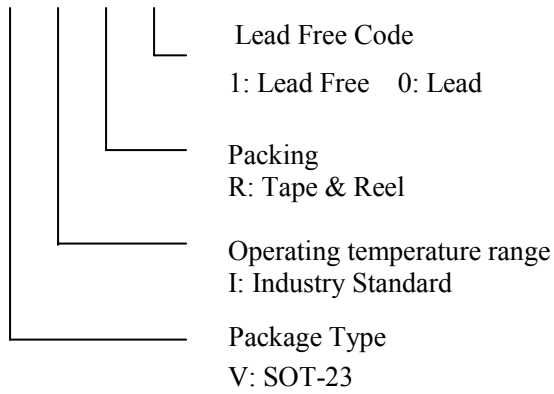

KTTIC

**Absolute Maximum Ratings**

- Input Supply Voltage ----- -0.3V to 6V
- EN, VFB Voltages ----- -0.3V to  $V_{IN}$
- P-Channel Switch Source Current (DC) ----- 800mA
- N-Channel Switch Sink Current (DC) ----- 800mA
- Peak SW Sink and Source Current ----- 1.4A
- Operating Temperature Range ----- -40°C to 85°C
- Junction Temperature ----- 125°C
- Storage Temperature ----- -65°C to 150°C
- Lead Temp (Soldering, 10sec) ----- 260°C
- ESD Rating (HBM) ----- 2kV

**Electrical Characteristics**

Unless otherwise specified,  $T_A=25^\circ\text{C}$ ,  $V_{IN}=3.6\text{V}$ .

Symbol	Parameter	Conditions	EUP3406			Unit
			Min	Typ	Max.	
$V_{IN}$	Input Voltage Range		2.5		5.5	V
$I_{VFB}$	Feedback Current			$\pm 30$		nA
$I_Q$	Quiescent Current	$V_{FB}=0.5\text{V}$		270	370	$\mu\text{A}$
$I_{SHDN}$	Shutdown Current	$V_{EN}=0\text{V}$ , $V_{IN}=4.2\text{V}$			1	$\mu\text{A}$
$I_{PK}$	Peak Inductor Current	$V_{IN}=3\text{V}$ , $V_{FB}=0.5\text{V}$	1	1.2	1.4	A
$V_{FB}$	Regulated Feedback Voltage	(Note 1)	0.588	0.6	0.612	V
$\Delta V_{OVL}$	$\Delta$ Output Overvoltage Lockout	$\Delta V_{OVL}=V_{OVL}-V_{FB}$	20	50	80	mV
$\Delta V_{OUT}$	Output Voltage Line Regulation	$V_{IN}=2.5\text{V}$ to $5.5\text{V}$ , $I_{LOAD}=0$		0.2	0.4	%/V
$\Delta V_{FB}$	Reference Voltage Line Regulation	$V_{IN}=2.5\text{V}$ to $5.5\text{V}$		0.2	0.4	%/V
$V_{LOADREG}$	Output Voltage Load Regulation	$I_{LOAD}=0\text{mA}$ to $600\text{mA}$		0.5		%
$f_{OSC}$	Oscillator Frequency	$V_{FB}=0.6\text{V}$	1.2	1.5	1.8	MHz
		$V_{FB}=0\text{V}$		210		kHz
$R_{PFET}$	$R_{DS(ON)}$ of P-Channel FET	$I_{SW}=100\text{mA}$		0.26	0.4	$\Omega$
$R_{NFET}$	$R_{DS(ON)}$ of N-Channel FET	$I_{SW}=-100\text{mA}$		0.28	0.4	$\Omega$
$I_{LSW}$	SW Leakage Current	$V_{EN}=0\text{V}$ , $V_{SW}=0\text{V}$ or $5\text{V}$ , $V_{IN}=5\text{V}$			$\pm 1$	$\mu\text{A}$
$V_{EN}$	EN Threshold		0.3	1.0	1.5	V
$I_{EN}$	EN Leakage Current				1	$\mu\text{A}$

Note 1: The EUP3406 is tested in a proprietary test mode that connects  $V_{FB}$  to the output of the error amplifier.

Typical Operating Characteristics

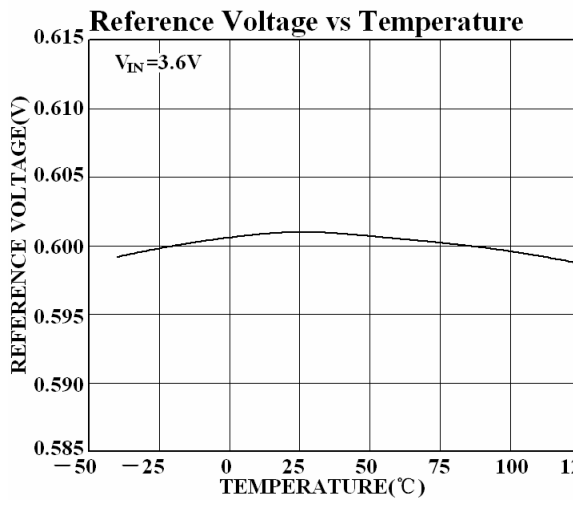
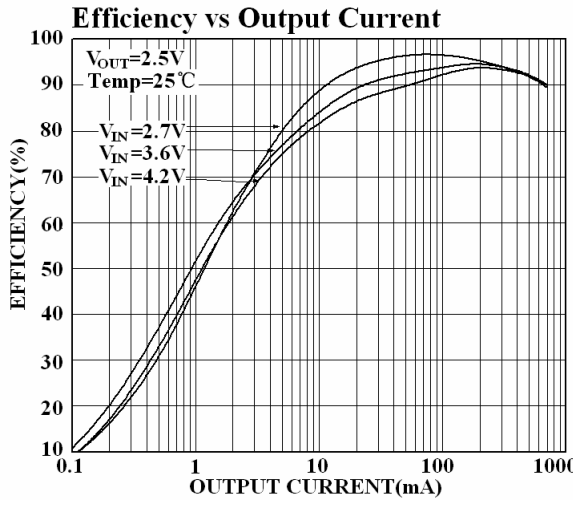
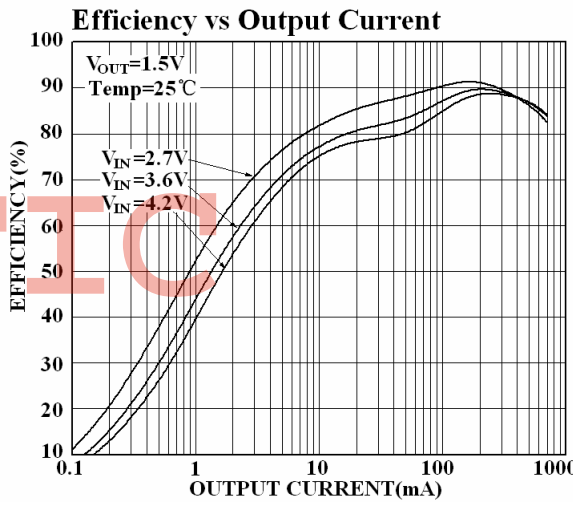
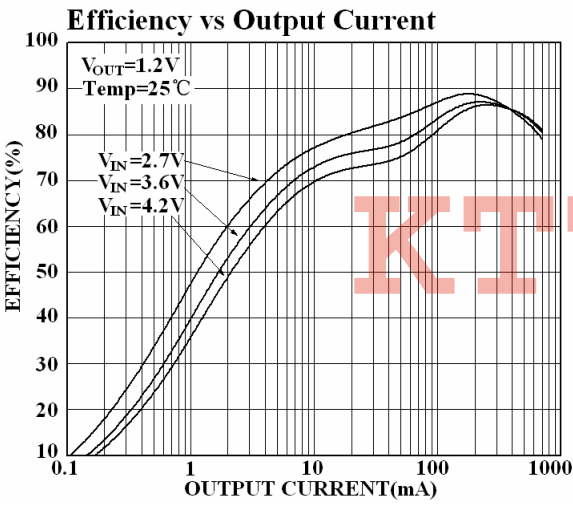
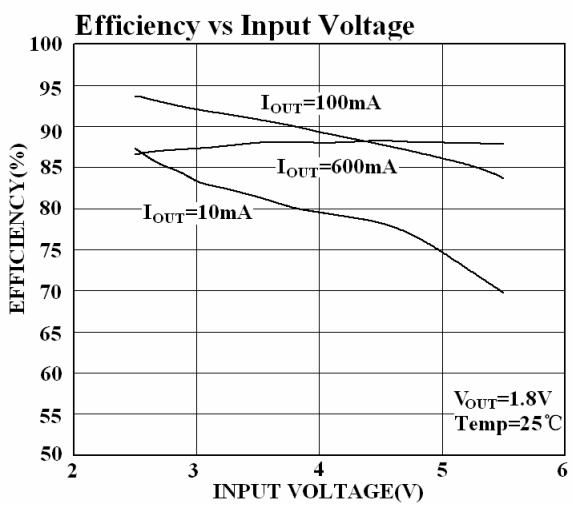
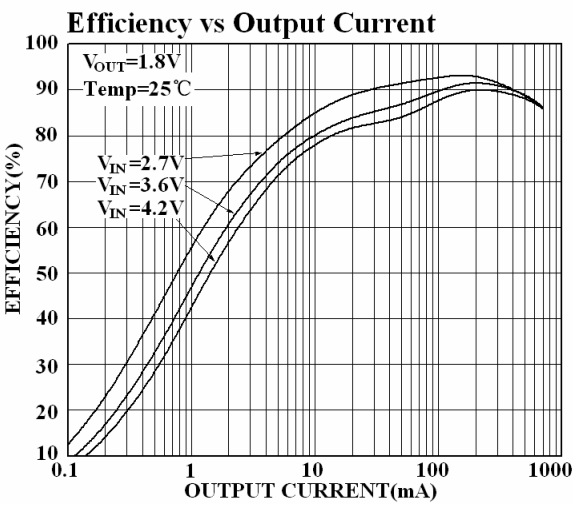

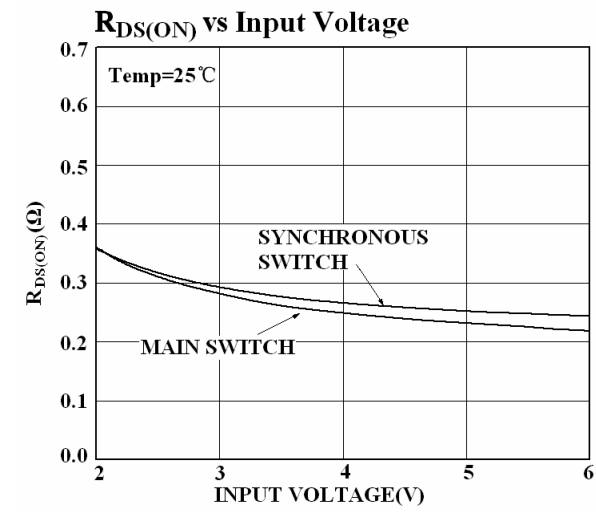
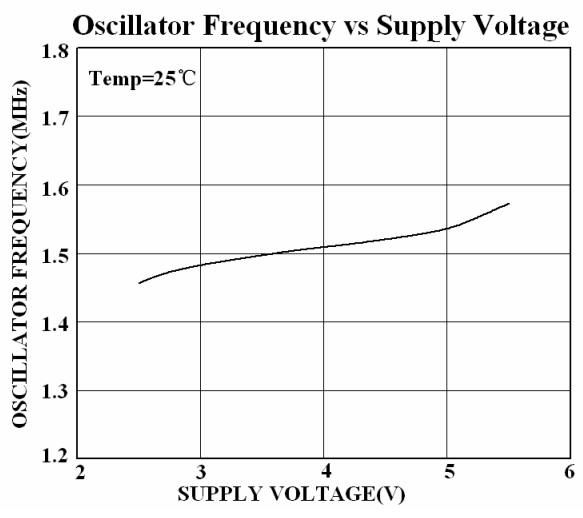
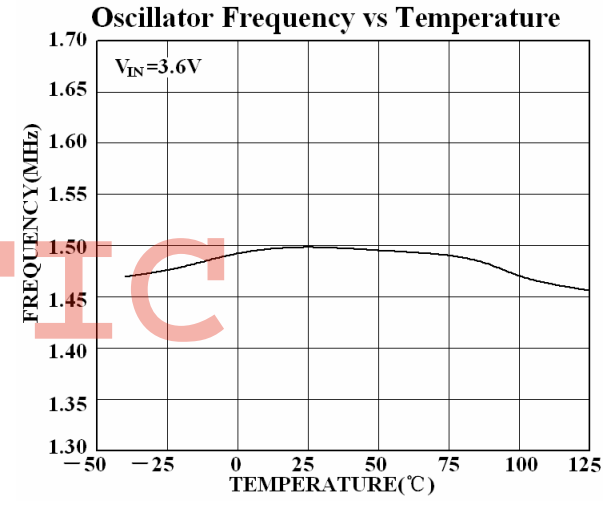
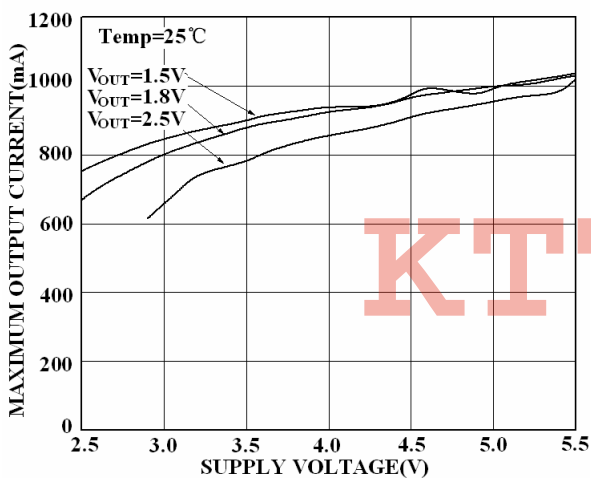
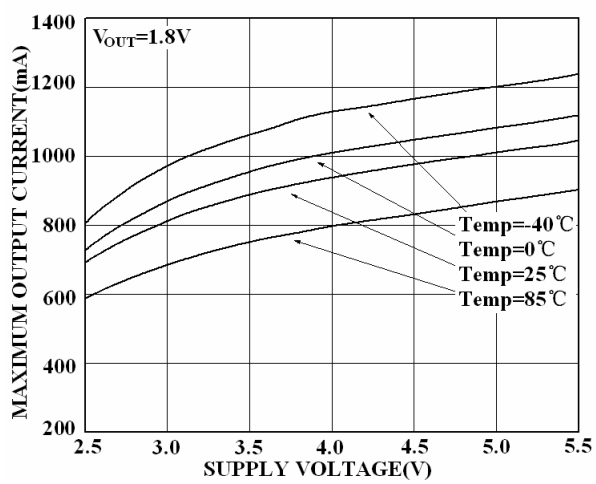
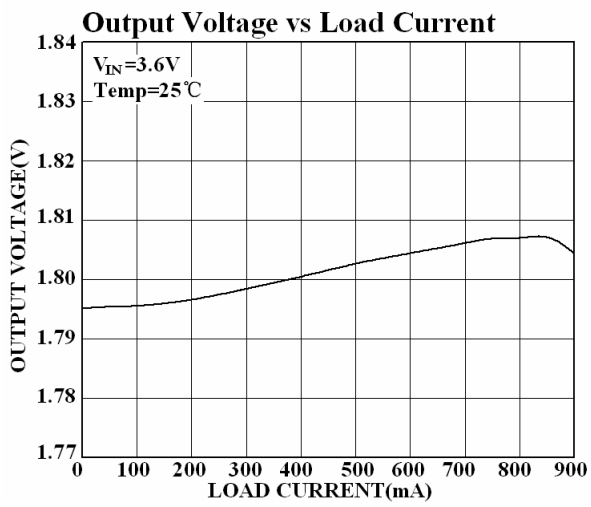

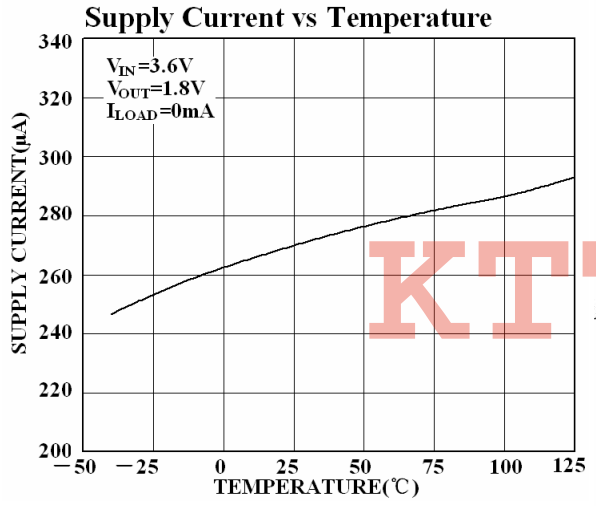
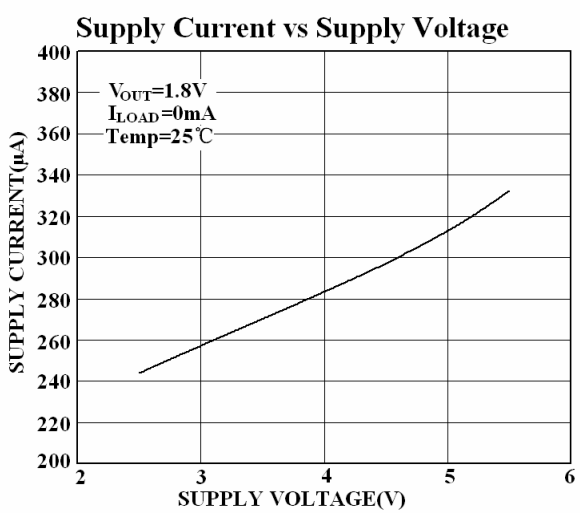
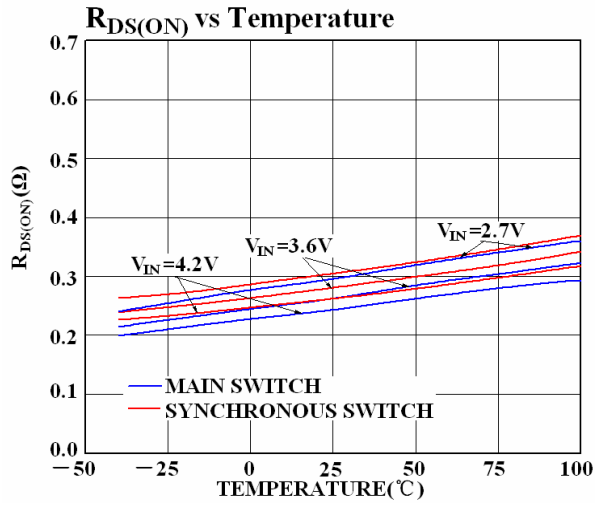

### Discontinuous Operation

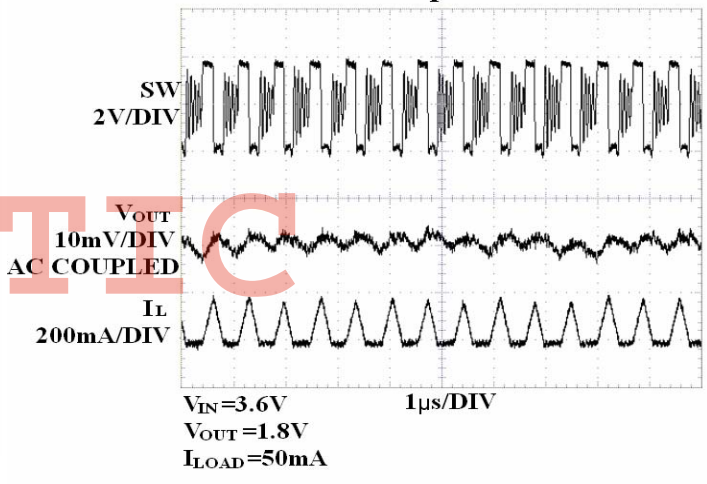

### Start-Up from Shutdown

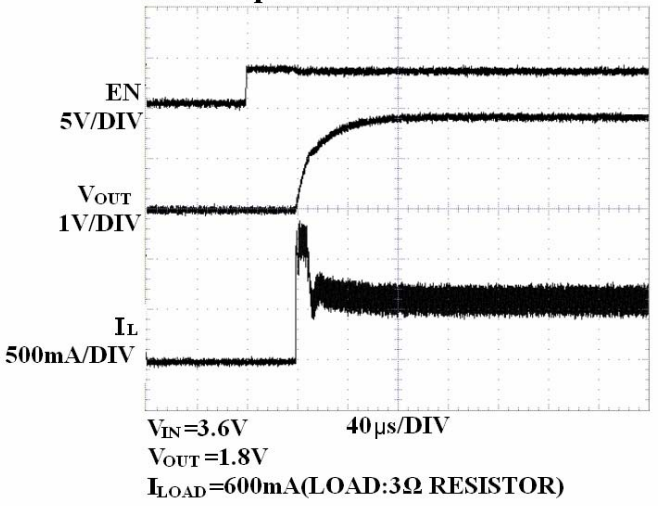

### Load Step

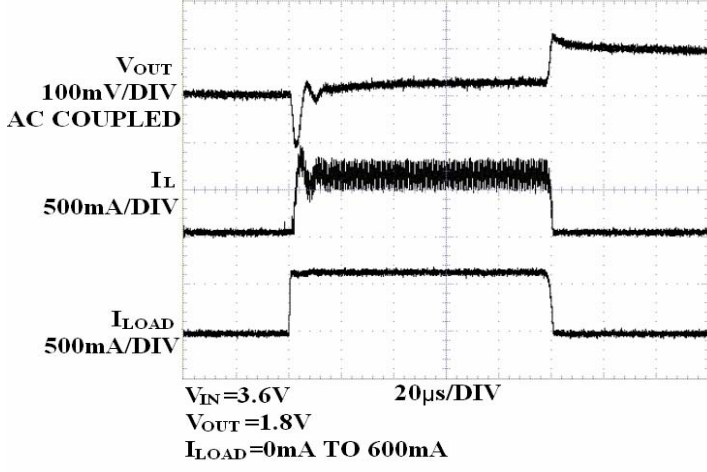

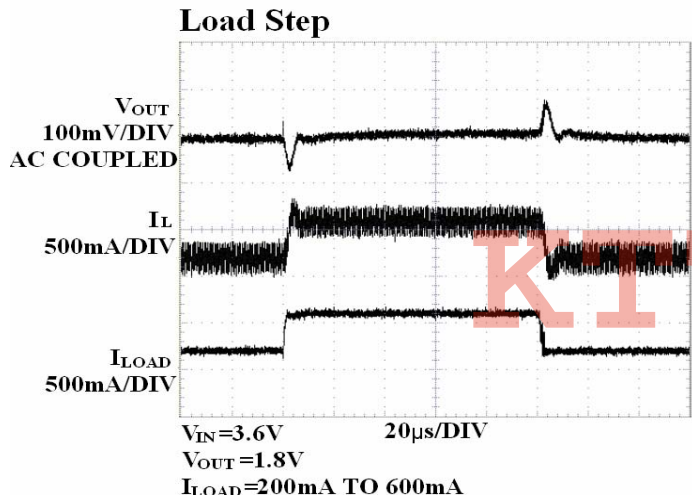
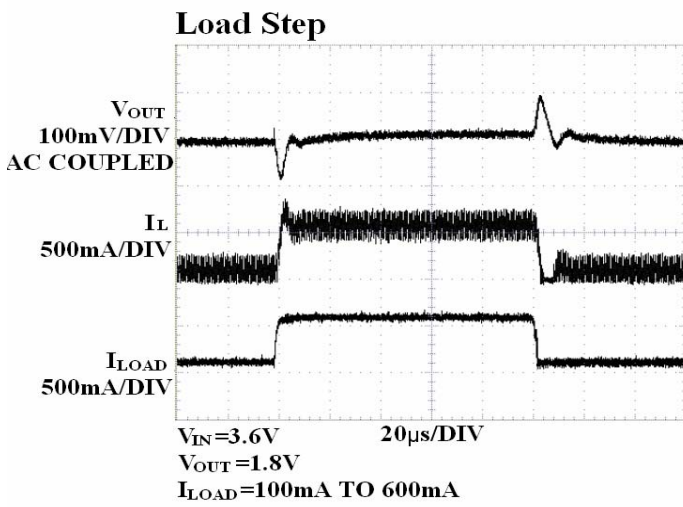
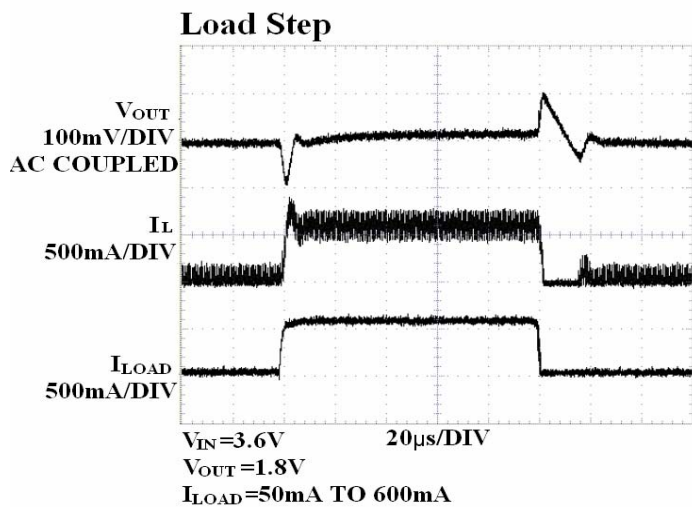

KTTIC



**Application Information**

**Main Control Loop**

The EUP3406 uses a slop-compensated constant frequency, current mode PWM architecture. Both the main (P-Channel MOSFET) and synchronous (N-channel MOSFET) switches are internal. During normal operation, the EUP3406 regulates output voltage by switching at a constant frequency and then modulating the power transferred to the load each cycle using PWM comparator. It sums three weighted differential signals: the output feedback voltage from an external resistor divider, the main switch current sense, and the slope-compensation ramp. It modulates output power by adjusting the inductor-peak current during the first half of each cycle. An N-channel, synchronous switch turns on during the second half of each cycle (off time). When the inductor current starts to reverse or when the PWM reaches the end of the oscillator period, the synchronous switch turns off. This keep excess current from flowing backward through the inductor, from the output capacitor to GND, or through the main and synchronous switch to GND.

**Inductor Selection**

The output inductor is selected to limit the ripple current to some predetermined value, typically 20%~40% of the full load current at the maximum input voltage. Large value inductors lower ripple currents. Higher  $V_{IN}$  or  $V_{OUT}$  also increases the ripple current as shown in equation. A reasonable starting point for setting ripple current is  $\Delta I_L=240mA$  (40% of 600mA).

$$\Delta I_L = \frac{1}{f(L)} V_{OUT} \left( 1 - \frac{V_{OUT}}{V_{IN}} \right)$$

The DC current rating of the inductor should be at least equal to the maximum load current plus half the ripple current to prevent core saturation. Thus, a 720mA rated inductor should be enough for most applications (600mA+120mA). For better efficiency, choose a low DC-resistance inductor.

**C<sub>IN</sub> and C<sub>OUT</sub> Selection**

In continuous mode, the source current of the top MOSFET is a square wave of duty cycle  $V_{OUT}/V_{IN}$ . The primary function of the input capacitor is to provide a low impedance loop for the edges of pulsed current drawn by the EUP3406. A low ESR input capacitor sized for the maximum RMS current must be used. The size required will vary depending on the load, output voltage and input voltage source impedance characteristics. A typical value is around 4.7μF.

The input capacitor RMS current varies with the input voltage and the output voltage. The equation for the maximum RMS current in the input capacitor is:

$$I_{RMS} = I_O \times \sqrt{\frac{V_O}{V_{IN}} \times \left( 1 - \frac{V_O}{V_{IN}} \right)}$$

The output capacitor  $C_{OUT}$  has a strong effect on loop stability.

The selection of  $C_{OUT}$  is driven by the required effective series resistance (ESR).

ESR is a direct function of the volume of the capacitor; that is, physically larger capacitors have lower ESR. Once the ESR requirement for  $C_{OUT}$  has been met, the RMS current rating generally far exceeds the  $I_{RIPPLE(P-P)}$  requirement. The output ripple  $\Delta V_{OUT}$  is determined by:

$$\Delta V_{OUT} \cong \Delta I_L \left( ESR + \frac{1}{8fC_{OUT}} \right)$$

When choosing the input and output ceramic capacitors, choose the X5R or X7R dielectric formulations. These dielectrics have the best temperature and voltage characteristics of all the ceramics for a given value and size.

**Output Voltage Programming**

The output voltage is set by a resistive divider according to the following formula:

$$V_{OUT} = 0.6V \left( 1 + \frac{R2}{R1} \right)$$

The external resistive divider is connected to the output, allowing remote voltage sensing as shown in Figure3.

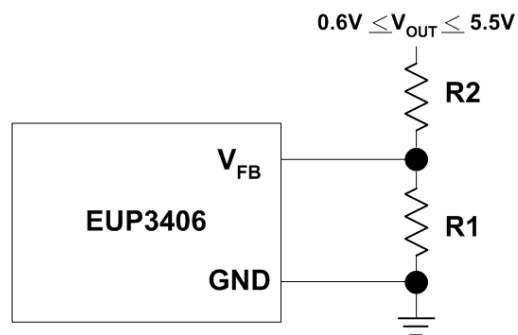

Figure3.

**Thermal Considerations**

To avoid the EUP3406 from exceeding the maximum junction temperature, the user will need to do a thermal analysis. The goal of the thermal analysis is to determine whether the operating conditions exceed the maximum junction temperature of the part. The temperature rise is given by:

$$T_R = (P_D)(\theta_{JA})$$

Where  $P_D = I_{LOAD}^2 \times R_{DS(ON)}$  is the power dissipated by the regulator ;  $\theta_{JA}$  is the thermal resistance from the junction of the die to the ambient temperature.

The junction temperature,  $T_J$ , is given by:

$$T_J = T_A + T_R$$

Where  $T_A$  is the ambient temperature.

$T_J$  should be below the maximum junction temperature of 125°C.

**PC Board Layout Checklist**

When laying out the printed circuit board, the following guidelines should be used to ensure proper operation of the EUP3406.

1. The input capacitor  $C_{IN}$  should connect to  $V_{IN}$  as closely as possible. This capacitor provides the AC current to the internal power MOSFETs.
2. The power traces, consisting of the GND trace, the SW trace and the  $V_{IN}$  trace should be kept short, direct and wide.
3. The  $V_{FB}$  pin should connect directly to the feedback resistors. The resistive divider R1/R2 must be connected between the  $C_{OUT}$  and ground.
4. Keep the switching node, SW, away from the sensitive  $V_{FB}$  node.

# KTTIC

Packaging Information

SOT23-5

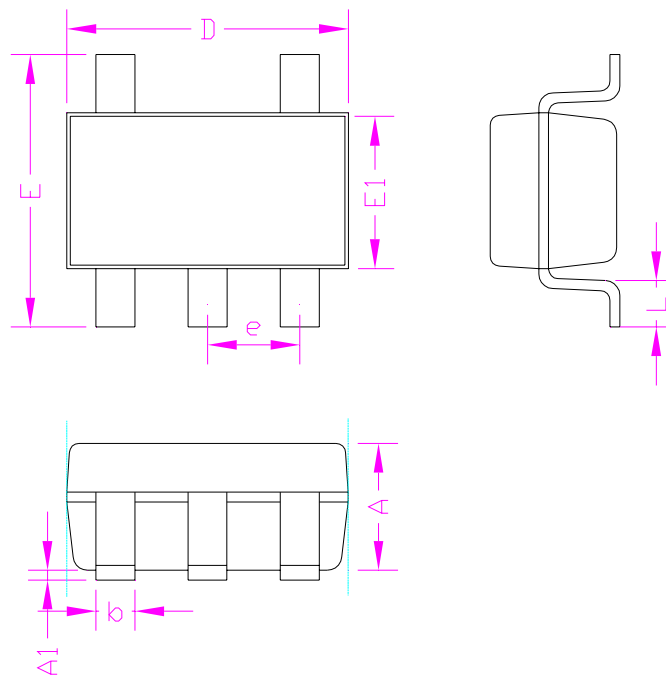

SYMBOLS	MILLIMETERS		INCHES	
	MIN.	MAX.	MIN.	MAX.
A	-	1.30	-	0.052
A1	0.00	0.15	0.000	0.006
D	2.90		0.114	
E1	1.60		0.063	
E	2.60	3.00	0.102	0.118
L	0.30	0.60	0.012	0.024
b	0.30	0.50	0.012	0.020
e	0.95		0.037	