

Features

- 80C31 Compatible
- 8031 pin and instruction compatible
- Four 8-bit I/O ports
- Two 16-bit timer/counters
- 128 bytes scratchpad RAM
- High-Speed Architecture
- 40 MHz @ 5V, 30MHz @ 3V
- X2 Speed Improvement capability (6 clocks/machine cycle)
- 30 MHz @ 5V, 20 MHz @ 3V (Equivalent to 60 MHz @ 5V, 40 MHz @ 3V)
- Dual Data Pointer
- Asynchronous port reset
- Interrupt Structure with
- 5 Interrupt sources,
- 4 priority level interrupt system
- Full duplex Enhanced UART
- Framing error detection
- Automatic address recognition
- Power Control modes
- Idle mode
- Power-down mode
- Power-off Flag
- Once mode (On-chip Emulation)
- Power supply: 4.5-5.5V, 2.7-5.5V
- Temperature ranges: Commercial (0 to 70°C) and Industrial (-40 to 85°C)
- Packages: PDIL40, PLCC44, VQFP44 1.4, PQFP F1 (13.9 footprint)

1. Description

TS80C31X2 is high performance CMOS and ROMless versions of the 80C51 CMOS single chip 8-bit microcontroller.

The TS80C31X2 retains all features of the TSC80C31 with 128 bytes of internal RAM, a 5-source, 4 priority level interrupt system, an on-chip oscillator and two timer/counters.

In addition, the TS80C31X2 has a dual data pointer, a more versatile serial channel that facilitates multiprocessor communication (EUART) and a X2 speed improvement mechanism.

The fully static design of the TS80C31X2 allows to reduce system power consumption by bringing the clock frequency down to any value, even DC, without loss of data.

The TS80C31X2 has 2 software-selectable modes of reduced activity for further reduction in power consumption. In the idle mode the CPU is frozen while the timers, the serial port and the interrupt system are still operating. In the power-down mode the RAM is saved and all other functions are inoperative.



**8-bit CMOS
Microcontroller
ROMless**

**TS80C31X2
AT80C31X2**



2. Block Diagram

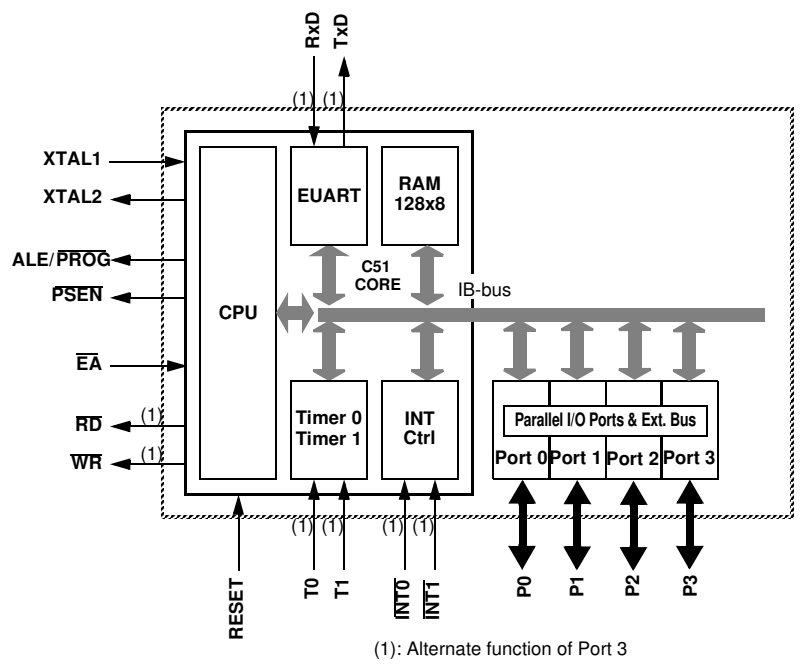

KTTIC

4. SFR Mapping

The Special Function Registers (SFRs) of the TS80C31X2 fall into the following categories:

- C51 core registers: ACC, B, DPH, DPL, PSW, SP, AUXR1
- I/O port registers: P0, P1, P2, P3
- Timer registers: TCON, TH0, TH1, TMOD, TL0, TL1
- Serial I/O port registers: SADDR, SADEN, SBUF, SCON
- Power and clock control registers: PCON
- Interrupt system registers: IE, IP, IPH
- Others: CKCON

Table 4-1. All SFRs with their address and their reset value

	Bit	Non Bit							
	addressable	addressable							
	0/8	1/9	2/A	3/B	4/C	5/D	6/E	7/F	
F8h									FFh
F0h	B 0000 0000								F7h
E8h									EFh
E0h	ACC 0000 0000								E7h
D8h									DFh
D0h	PSW 0000 0000								D7h
C8h									CFh
C0h									C7h
B8h	IP XXX0 0000	SADEN 0000 0000							BFh
B0h	P3 1111 1111							IPH XXX0 0000	B7h
A8h	IE 0XX0 0000	SADDR 0000 0000							AFh
A0h	P2 1111 1111		AUXR1 XXXX XXX0						A7h
98h	SCON 0000 0000	SBUF XXXX XXXX							9Fh
90h	P1 1111 1111								97h
88h	TCON 0000 0000	TMOD 0000 0000	TL0 0000 0000	TL1 0000 0000	TH0 0000 0000	TH1 0000 0000		CKCON XXXX XXX0	8Fh
80h	P0 1111 1111	SP 0000 0111	DPL 0000 0000	DPH 0000 0000				PCON 00X1 0000	87h
	0/8	1/9	2/A	3/B	4/C	5/D	6/E	7/F	

Reserved

5. Pin Configuration

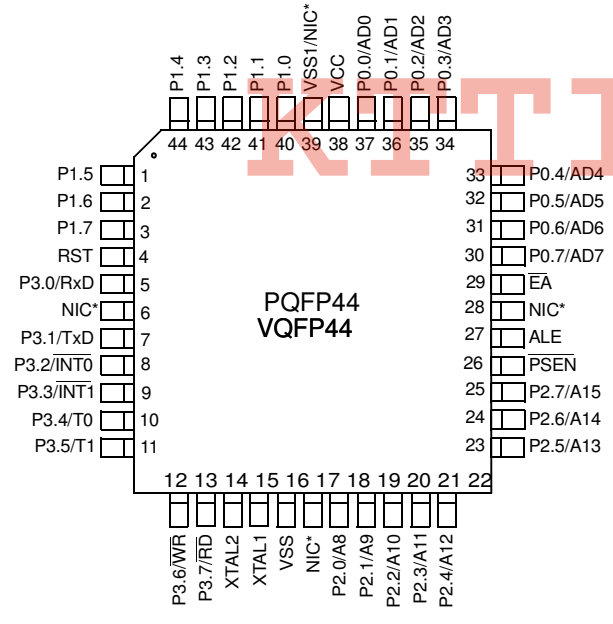
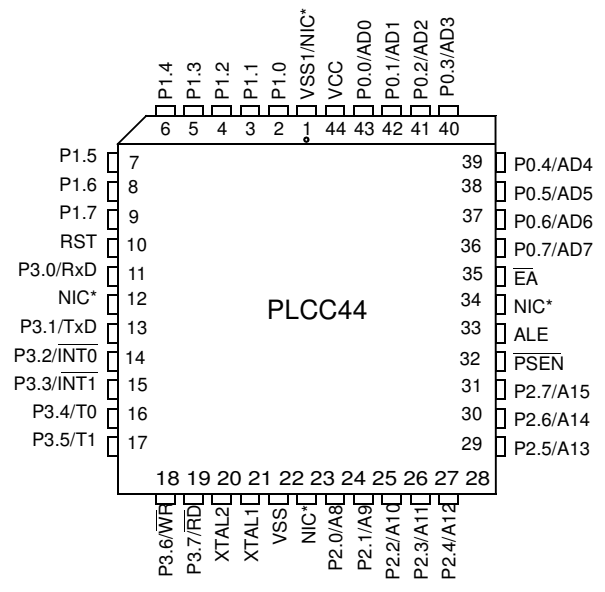
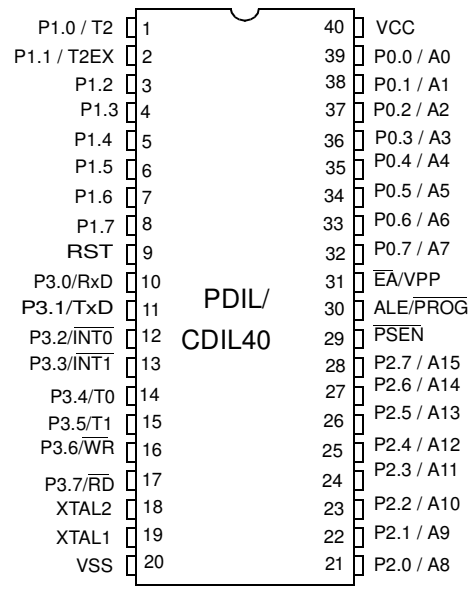

*NIC: No Internal Connection

Mnemonic	Pin Number			Type	Name And Function
	DIL	LCC	VQFP 1.4		
V _{SS}	20	22	16	I	Ground: 0V reference
V _{SS1}		1	39	I	Optional Ground: Contact the Sales Office for ground connection.
V _{CC}	40	44	38	I	Power Supply: This is the power supply voltage for normal, idle and power-down operation
P0.0-P0.7	39-32	43-36	37-30	I/O	Port 0: Port 0 is an open-drain, bidirectional I/O port. Port 0 pins that have 1s written to them float and can be used as high impedance inputs. Port 0 pins must be polarized to V _{cc} or V _{ss} in order to prevent any parasitic current consumption. Port 0 is also the multiplexed low-order address and data bus during access to external program and data memory. In this application, it uses strong internal pull-up when emitting 1s.
P1.0-P1.7	1-8	2-9	40-44 1-3	I/O	Port 1: Port 1 is an 8-bit bidirectional I/O port with internal pull-ups. Port 1 pins that have 1s written to them are pulled high by the internal pull-ups and can be used as inputs. As inputs, Port 1 pins that are externally pulled low will source current because of the internal pull-ups.
P2.0-P2.7	21-28	24-31	18-25	I/O	Port 2: Port 2 is an 8-bit bidirectional I/O port with internal pull-ups. Port 2 pins that have 1s written to them are pulled high by the internal pull-ups and can be used as inputs. As inputs, Port 2 pins that are externally pulled low will source current because of the internal pull-ups. Port 2 emits the high-order address byte during fetches from external program memory and during accesses to external data memory that use 16-bit addresses (MOVX @DPTR). In this application, it uses strong internal pull-ups emitting 1s. During accesses to external data memory that use 8-bit addresses (MOVX @Ri), port 2 emits the contents of the P2 SFR.
P3.0-P3.7	10-17	11, 13-19	5, 7-13	I/O	Port 3: Port 3 is an 8-bit bidirectional I/O port with internal pull-ups. Port 3 pins that have 1s written to them are pulled high by the internal pull-ups and can be used as inputs. As inputs, Port 3 pins that are externally pulled low will source current because of the internal pull-ups. Port 3 also serves the special features of the 80C51 family, as listed below.
	10	11	5	I	RXD (P3.0): Serial input port
	11	13	7	O	TXD (P3.1): Serial output port
	12	14	8	I	INT0 (P3.2): External interrupt 0
	13	15	9	I	INT1 (P3.3): External interrupt 1
	14	16	10	I	T0 (P3.4): Timer 0 external input
	15	17	11	I	T1 (P3.5): Timer 1 external input
	16	18	12	O	WR (P3.6): External data memory write strobe
	17	19	13	O	RD (P3.7): External data memory read strobe
Reset	9	10	4	I	Reset: A high on this pin for two machine cycles while the oscillator is running, resets the device. An internal diffused resistor to V _{SS} permits a power-on reset using only an external capacitor to V _{CC} .
ALE	30	33	27	O (I)	Address Latch Enable: Output pulse for latching the low byte of the address during an access to external memory. In normal operation, ALE is emitted at a constant rate of 1/6 (1/3 in X2 mode) the oscillator frequency, and can be used for external timing or clocking. Note that one ALE pulse is skipped during each access to external data memory.
PSEN	29	32	26	O	Program Store ENable: The read strobe to external program memory. When executing code from the external program memory, PSEN is activated twice each machine cycle, except that two PSEN activations are skipped during each access to external data memory. PSEN is not activated during fetches from internal program memory.



EA	31	35	29	I	External Access Enable: \overline{EA} must be externally held low to enable the device to fetch code from external program memory locations.
XTAL1	19	21	15	I	Crystal 1: Input to the inverting oscillator amplifier and input to the internal clock generator circuits.
XTAL2	18	20	14	O	Crystal 2: Output from the inverting oscillator amplifier

KTTIC

6. TS80C31X2 Enhanced Features

In comparison to the original 80C31, the TS80C31X2 implements some new features, which are:

- The X2 option.
- The Dual Data Pointer.
- The 4 level interrupt priority system.
- The power-off flag.
- The ONCE mode.
- Enhanced UART

6.1 X2 Feature

The TS80C31X2 core needs only 6 clock periods per machine cycle. This feature called "X2" provides the following advantages:

- Divide frequency crystals by 2 (cheaper crystals) while keeping same CPU power.
- Save power consumption while keeping same CPU power (oscillator power saving).
- Save power consumption by dividing dynamically operating frequency by 2 in operating and idle modes.
- Increase CPU power by 2 while keeping same crystal frequency.

In order to keep the original C51 compatibility, a divider by 2 is inserted between the XTAL1 signal and the main clock input of the core (phase generator). This divider may be disabled by software.

6.1.1 Description

The clock for the whole circuit and peripheral is first divided by two before being used by the CPU core and peripherals. This allows any cyclic ratio to be accepted on XTAL1 input. In X2 mode, as this divider is bypassed, the signals on XTAL1 must have a cyclic ratio between 40 to 60%. Figure 6-1. shows the clock generation block diagram. X2 bit is validated on XTAL1÷2 rising edge to avoid glitches when switching from X2 to STD mode. Figure 6-2. shows the mode switching waveforms.

Figure 6-1. Clock Generation Diagram

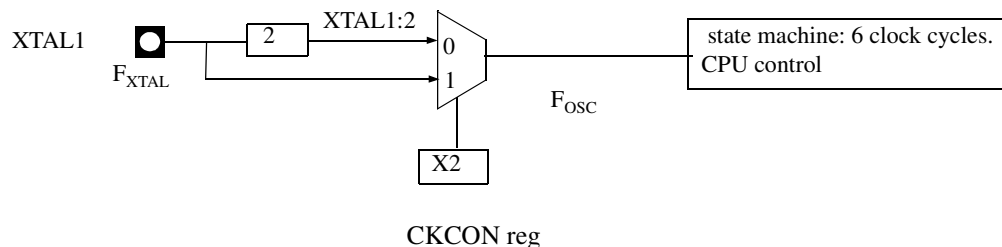
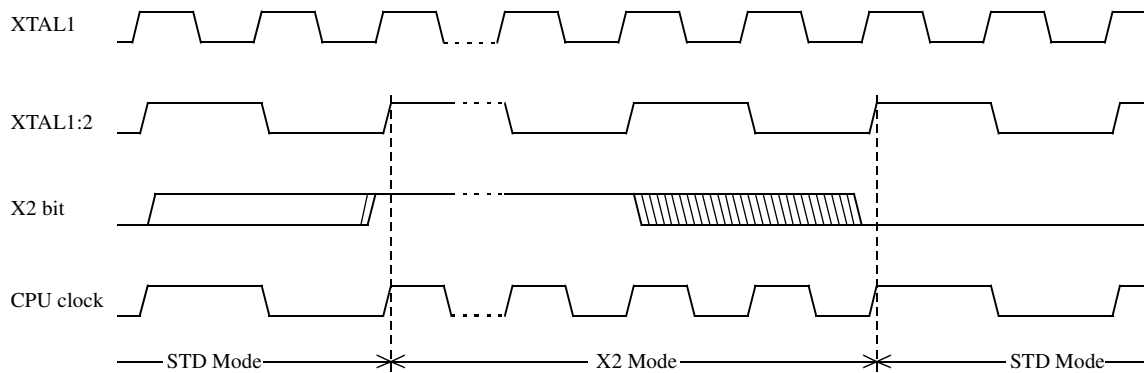

Figure 6-2. Mode Switching Waveforms



The X2 bit in the CKCON register (See Table 6-1.) allows to switch from 12 clock cycles per instruction to 6 clock cycles and vice versa. At reset, the standard speed is activated (STD mode). Setting this bit activates the X2 feature (X2 mode).

CAUTION

In order to prevent any incorrect operation while operating in X2 mode, user must be aware that all peripherals using clock frequency as time reference (UART, timers) will have their time reference divided by two. For example a free running timer generating an interrupt every 20 ms will then generate an interrupt every 10 ms. UART with 4800 baud rate will have 9600 baud rate.

Table 6-1. CKCON Register
CKCON - Clock Control Register (8Fh)

Bit Number	Bit Mnemonic	Description
7	-	Reserved The value read from this bit is indeterminate. Do not set this bit.
6	-	Reserved The value read from this bit is indeterminate. Do not set this bit.
5	-	Reserved The value read from this bit is indeterminate. Do not set this bit.
4	-	Reserved The value read from this bit is indeterminate. Do not set this bit.
3	-	Reserved The value read from this bit is indeterminate. Do not set this bit.
2	-	Reserved The value read from this bit is indeterminate. Do not set this bit.
1	-	Reserved The value read from this bit is indeterminate. Do not set this bit.
0	X2	CPU and peripheral clock bit Clear to select 12 clock periods per machine cycle (STD mode, $F_{OSC}=F_{XTAL}/2$). Set to select 6 clock periods per machine cycle (X2 mode, $F_{OSC}=F_{XTAL}$).

Reset Value = XXXX XXX0b

Not bit addressable

For further details on the X2 feature, please refer to ANM072 available on the web (<http://www.atmel-wm.com>)

7. Dual Data Pointer Register Ddptr

The additional data pointer can be used to speed up code execution and reduce code size in a number of ways.

The dual DPTR structure is a way by which the chip will specify the address of an external data memory location. There are two 16-bit DPTR registers that address the external memory, and a single bit called DPS = AUXR1/bit0 (See Table 5.) that allows the program code to switch between them (Refer to Figure 7-1).

Figure 7-1. Use of Dual Pointer

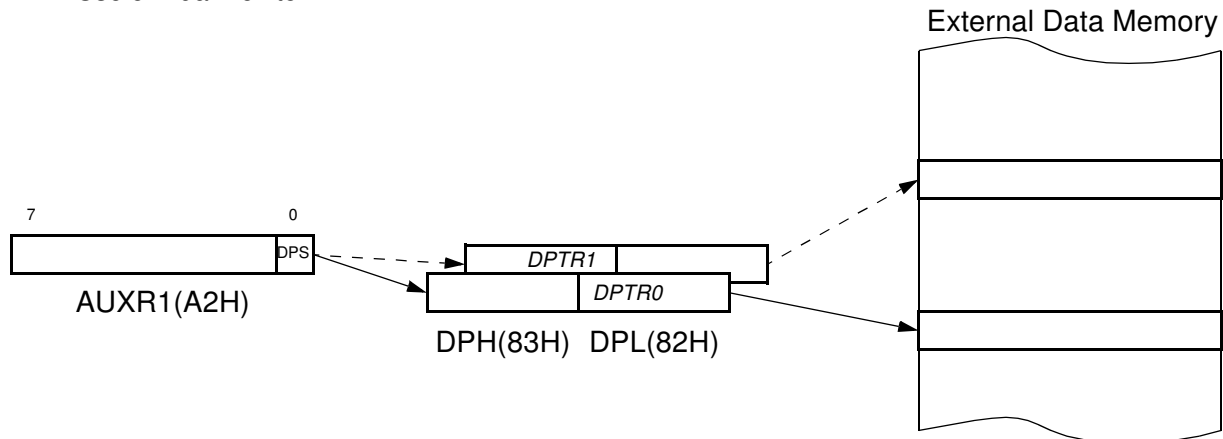

Table 7-1. AUXR1: Auxiliary Register 1

Bit Number	Bit Mnemonic	Description
7	-	Reserved The value read from this bit is indeterminate. Do not set this bit.
6	-	Reserved The value read from this bit is indeterminate. Do not set this bit.
5	-	Reserved The value read from this bit is indeterminate. Do not set this bit.
4	-	Reserved The value read from this bit is indeterminate. Do not set this bit.
3	-	Reserved The value read from this bit is indeterminate. Do not set this bit.
2	-	Reserved The value read from this bit is indeterminate. Do not set this bit.
1	-	Reserved The value read from this bit is indeterminate. Do not set this bit.
0	DPS	Data Pointer Selection Clear to select DPTR0. Set to select DPTR1.

Reset Value = XXXX XXX0

Not bit addressable

8. Application

Software can take advantage of the additional data pointers to both increase speed and reduce code size, for example, block operations (copy, compare, search ...) are well served by using one data pointer as a 'source' pointer and the other one as a "destination" pointer.

ASSEMBLY LANGUAGE

```

; Block move using dual data pointers
; Destroys DPTR0, DPTR1, A and PSW
; note: DPS exits opposite of entry state
; unless an extra INC AUXR1 is added
;
00A2          AUXR1 EQU 0A2H
;
0000 909000   MOV  DPTR,#SOURCE      ; address of SOURCE
0003 05A2     INC  AUXR1          ; switch data pointers
0005 90A000   MOV  DPTR,#DEST      ; address of DEST
0008          LOOP:
0008 05A2     INC  AUXR1          ; switch data pointers
000A E0       MOVX A,@DPTR      ; get a byte from SOURCE
000B A3       INC  DPTR          ; increment SOURCE address
000C 05A2     INC  AUXR1          ; switch data pointers
000E F0       MOVX @DPTR,A      ; write the byte to DEST
000F A3       INC  DPTR          ; increment DEST address
0010 70F6     JNZ  LOOP          ; check for 0 terminator
0012 05A2     INC  AUXR1          ; (optional) restore DPS

```

INC is a short (2 bytes) and fast (12 clocks) way to manipulate the DPS bit in the AUXR1 SFR. However, note that the INC instruction does not directly force the DPS bit to a particular state, but simply toggles it. In simple routines, such as the block move example, only the fact that DPS is toggled in the proper sequence matters, not its actual value. In other words, the block move routine works the same whether DPS is '0' or '1' on entry. Observe that without the last instruction (INC AUXR1), the routine will exit with DPS in the opposite state.

9. TS80C31X2 Serial I/O Port

The serial I/O port in the TS80C31X2 is compatible with the serial I/O port in the 80C31. It provides both synchronous and asynchronous communication modes. It operates as an Universal Asynchronous Receiver and Transmitter (UART) in three full-duplex modes (Modes 1, 2 and 3). Asynchronous transmission and reception can occur simultaneously and at different baud rates

Serial I/O port includes the following enhancements:

- Framing error detection
- Automatic address recognition

9.1 Framing Error Detection

Framing bit error detection is provided for the three asynchronous modes (modes 1, 2 and 3). To enable the framing bit error detection feature, set SMOD0 bit in PCON register (See Figure 9-1).

Figure 9-1. Framing Error Block Diagram

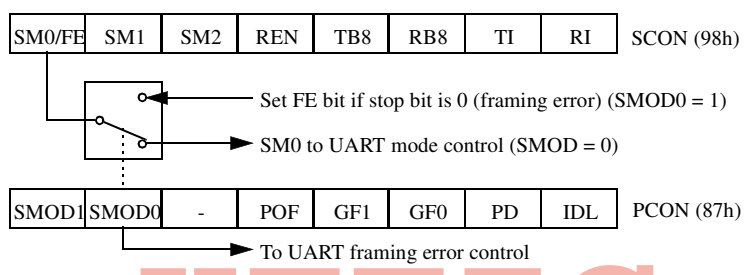

When this feature is enabled, the receiver checks each incoming data frame for a valid stop bit. An invalid stop bit may result from noise on the serial lines or from simultaneous transmission by two CPUs. If a valid stop bit is not found, the Framing Error bit (FE) in SCON register (See Table 9-3.) bit is set.

Software may examine FE bit after each reception to check for data errors. Once set, only software or a reset can clear FE bit. Subsequently received frames with valid stop bits cannot clear FE bit. When FE feature is enabled, RI rises on stop bit instead of the last data bit (See Figure 9-2. and Figure 9-3.).

Figure 9-2. UART Timings in Mode 1

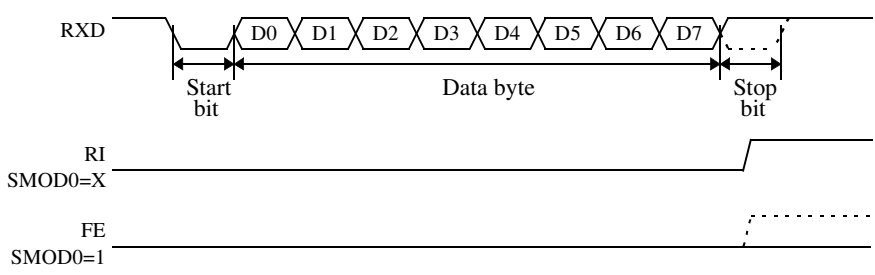
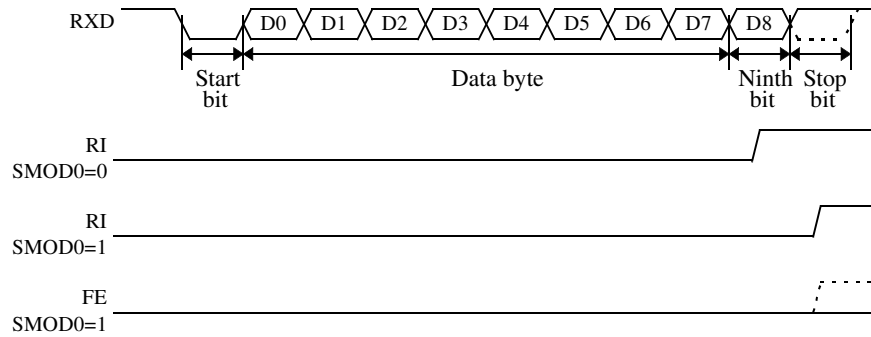

Figure 9-3. UART Timings in Modes 2 and 3



9.2 Automatic Address Recognition

The automatic address recognition feature is enabled when the multiprocessor communication feature is enabled (SM2 bit in SCON register is set).

Implemented in hardware, automatic address recognition enhances the multiprocessor communication feature by allowing the serial port to examine the address of each incoming command frame. Only when the serial port recognizes its own address, the receiver sets RI bit in SCON register to generate an interrupt. This ensures that the CPU is not interrupted by command frames addressed to other devices.

If desired, you may enable the automatic address recognition feature in mode 1. In this configuration, the stop bit takes the place of the ninth data bit. Bit RI is set only when the received command frame address matches the device's address and is terminated by a valid stop bit.

To support automatic address recognition, a device is identified by a given address and a broadcast address.

NOTE: The multiprocessor communication and automatic address recognition features cannot be enabled in mode 0 (i.e. setting SM2 bit in SCON register in mode 0 has no effect).

9.3 Given Address

Each device has an individual address that is specified in SADDR register; the SADEN register is a mask byte that contains don't-care bits (defined by zeros) to form the device's given address. The don't-care bits provide the flexibility to address one or more slaves at a time. The following example illustrates how a given address is formed.

To address a device by its individual address, the SADEN mask byte must be 1111 1111b.

For example:

SADDR	0101 0110b
<u>SADEN</u>	<u>1111 1100b</u>
Given	0101 01XXb

The following is an example of how to use given addresses to address different slaves:

Slave A:	SADDR	1111 0001b
	<u>SADEN</u>	<u>1111 1010b</u>
	Given	1111 0X0Xb

Slave B:	SADDR	1111 0011b
	<u>SADEN</u>	<u>1111 1001b</u>
	Given	1111 0XX1b

```
Slave C:  SADDR      1111 0010b
          SADEN      1111 1101b
          Given      1111 00X1b
```

The SADEN byte is selected so that each slave may be addressed separately. For slave A, bit 0 (the LSB) is a don't-care bit; for slaves B and C, bit 0 is a 1. To communicate with slave A only, the master must send an address where bit 0 is clear (e.g. 1111 0000b). For slave A, bit 1 is a 1; for slaves B and C, bit 1 is a don't care bit. To communicate with slaves B and C, but not slave A, the master must send an address with bits 0 and 1 both set (e.g. 1111 0011b). To communicate with slaves A, B and C, the master must send an address with bit 0 set, bit 1 clear, and bit 2 clear (e.g. 1111 0001b).

9.4 Broadcast Address

A broadcast address is formed from the logical OR of the SADDR and SADEN registers with zeros defined as don't-care bits, e.g.:

```
          SADDR      0101 0110b
          SADEN      1111 1100b
Broadcast =SADDR OR SADEN  1111 111Xb
```

The use of don't-care bits provides flexibility in defining the broadcast address, however in most applications, a broadcast address is FFh. The following is an example of using broadcast addresses:

```
Slave A:  SADDR      1111 0001b
          SADEN      1111 1010b
          Broadcast  1111 1X11b,
Slave B:  SADDR      1111 0011b
          SADEN      1111 1001b
          Broadcast  1111 1X11b,
Slave C:  SADDR=     1111 0010b
          SADEN      1111 1101b
          Broadcast  1111 1111b
```

For slaves A and B, bit 2 is a don't care bit; for slave C, bit 2 is set. To communicate with all of the slaves, the master must send an address FFh. To communicate with slaves A and B, but not slave C, the master can send an address FBh.

9.5 Reset Addresses

On reset, the SADDR and SADEN registers are initialized to 00h, i.e. the given and broadcast addresses are XXXX XXXXb (all don't-care bits). This ensures that the serial port will reply to any address, and so, that it is backwards compatible with the 80C51 microcontrollers that do not support automatic address recognition.

Table 9-1. SADEN - Slave Address Mask Register (B9h)

7	6	5	4	3	2	1	0

Reset Value = 0000 0000b
Not bit addressable



Table 9-2. SADDR - Slave Address Register (A9h)

7	6	5	4	3	2	1	0

Reset Value = 0000 0000b

Not bit addressable

KTTIC

Table 9-3. SCON Register -- SCON - Serial Control Register (98h)

7	6	5	4	3	2	1	0																									
FE/SM0	SM1	SM2	REN	TB8	RB8	TI	RI																									
Bit Number	Bit Mnemonic	Description																														
7	FE	Framing Error bit (SMOD0=1) Clear to reset the error state, not cleared by a valid stop bit. Set by hardware when an invalid stop bit is detected. SMOD0 must be set to enable access to the FE bit																														
	SM0	Serial port Mode bit 0 Refer to SM1 for serial port mode selection. SMOD0 must be cleared to enable access to the SM0 bit																														
6	SM1	Serial port Mode bit 1 <table border="1"> <thead> <tr> <th>SM0</th> <th>SM1</th> <th>Mode</th> <th>Description</th> <th>Baud Rate</th> </tr> </thead> <tbody> <tr> <td>0</td> <td>0</td> <td>0</td> <td>Shift Register</td> <td>$F_{XTAL}/12$ (/6 in X2 mode)</td> </tr> <tr> <td>0</td> <td>1</td> <td>1</td> <td>8-bit UART</td> <td>Variable</td> </tr> <tr> <td>1</td> <td>0</td> <td>2</td> <td>9-bit UART</td> <td>$F_{XTAL}/64$ or $F_{XTAL}/32$ (/32, /16 in X2 mode)</td> </tr> <tr> <td>1</td> <td>1</td> <td>3</td> <td>9-bit UART</td> <td>Variable</td> </tr> </tbody> </table>						SM0	SM1	Mode	Description	Baud Rate	0	0	0	Shift Register	$F_{XTAL}/12$ (/6 in X2 mode)	0	1	1	8-bit UART	Variable	1	0	2	9-bit UART	$F_{XTAL}/64$ or $F_{XTAL}/32$ (/32, /16 in X2 mode)	1	1	3	9-bit UART	Variable
SM0	SM1	Mode	Description	Baud Rate																												
0	0	0	Shift Register	$F_{XTAL}/12$ (/6 in X2 mode)																												
0	1	1	8-bit UART	Variable																												
1	0	2	9-bit UART	$F_{XTAL}/64$ or $F_{XTAL}/32$ (/32, /16 in X2 mode)																												
1	1	3	9-bit UART	Variable																												
5	SM2	Serial port Mode 2 bit / Multiprocessor Communication Enable bit Clear to disable multiprocessor communication feature. Set to enable multiprocessor communication feature in mode 2 and 3, and eventually mode 1. This bit should be cleared in mode 0.																														
4	REN	Reception Enable bit Clear to disable serial reception. Set to enable serial reception.																														
3	TB8	Transmitter Bit 8 / Ninth bit to transmit in modes 2 and 3. Clear to transmit a logic 0 in the 9th bit. Set to transmit a logic 1 in the 9th bit.																														
2	RB8	Receiver Bit 8 / Ninth bit received in modes 2 and 3 Cleared by hardware if 9th bit received is a logic 0. Set by hardware if 9th bit received is a logic 1. In mode 1, if SM2 = 0, RB8 is the received stop bit. In mode 0 RB8 is not used.																														
1	TI	Transmit Interrupt flag Clear to acknowledge interrupt. Set by hardware at the end of the 8th bit time in mode 0 or at the beginning of the stop bit in the other modes.																														
0	RI	Receive Interrupt flag Clear to acknowledge interrupt. Set by hardware at the end of the 8th bit time in mode 0, see Figure 9-2. and Figure 9-3. in the other modes.																														

Reset Value = 0000 0000b

Bit addressable

Table 9-4. PCON Register -- PCON - Power Control Register (87h)

7	6	5	4	3	2	1	0
SMOD1	SMOD0	-	POF	GF1	GF0	PD	IDL

Bit Number	Bit Mnemonic	Description
7	SMOD1	Serial port Mode bit 1 Set to select double baud rate in mode 1, 2 or 3.
6	SMOD0	Serial port Mode bit 0 Clear to select SM0 bit in SCON register. Set to to select FE bit in SCON register.
5	-	Reserved The value read from this bit is indeterminate. Do not set this bit.
4	POF	Power-Off Flag Clear to recognize next reset type. Set by hardware when VCC rises from 0 to its nominal voltage. Can also be set by software.
3	GF1	General purpose Flag Cleared by user for general purpose usage. Set by user for general purpose usage.
2	GF0	General purpose Flag Cleared by user for general purpose usage. Set by user for general purpose usage.
1	PD	Power-Down mode bit Cleared by hardware when reset occurs. Set to enter power-down mode.
0	IDL	Idle mode bit Clear by hardware when interrupt or reset occurs. Set to enter idle mode.

Reset Value = 00X1 0000b

Not bit addressable

Power-off flag reset value will be 1 only after a power on (cold reset). A warm reset doesn't affect the value of this bit.

10. Interrupt System

The TS80C31X2 has a total of 5 interrupt vectors: two external interrupts ($\overline{INT0}$ and $\overline{INT1}$), two timer interrupts (timers 0 and 1) and the serial port interrupt. These interrupts are shown in Figure 10-1.

Figure 10-1. Interrupt Control System

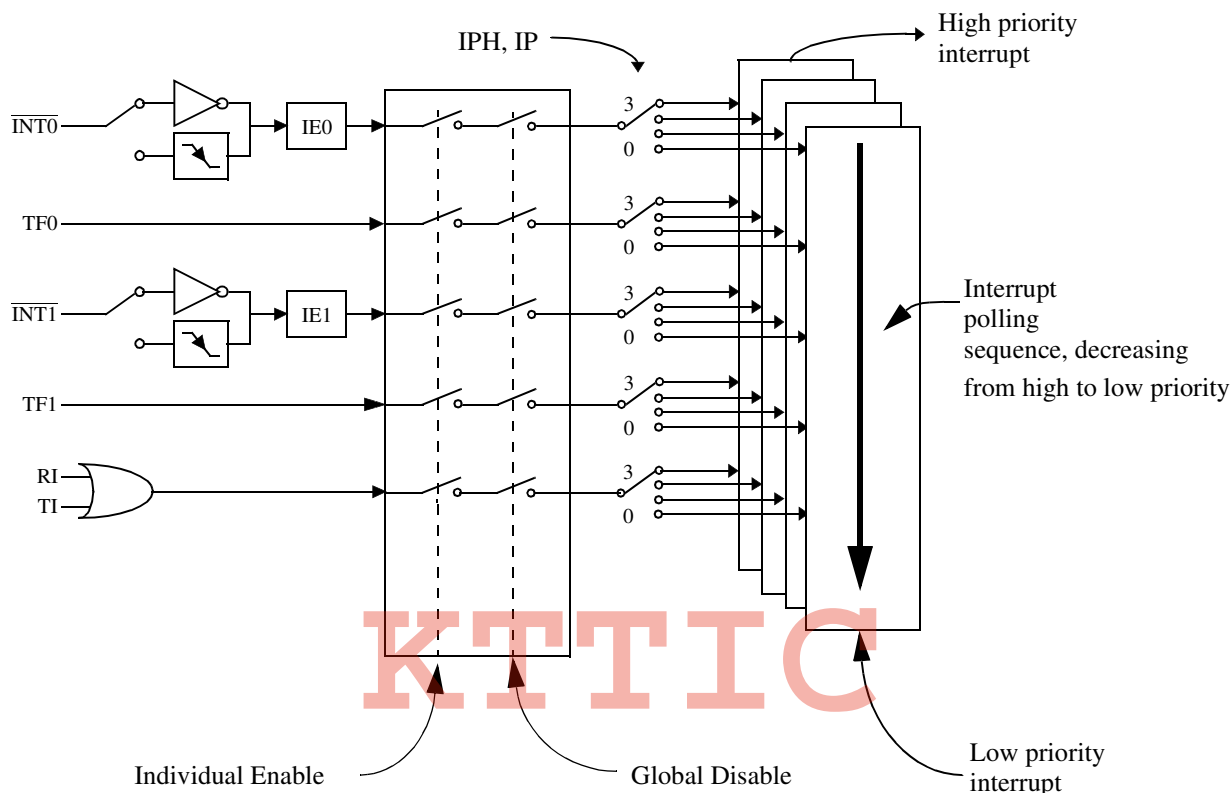

Each of the interrupt sources can be individually enabled or disabled by setting or clearing a bit in the Interrupt Enable register (See Table 10-2. Table 10-3.). This register also contains a global disable bit, which must be cleared to disable all interrupts at once.

Each interrupt source can also be individually programmed to one out of four priority levels by setting or clearing a bit in the Interrupt Priority register (See Table 10-3.) and in the Interrupt Priority High register (See Table 10-4.). shows the bit values and priority levels associated with each combination.

Table 10-1. Priority Level Bit Values

IPH.x	IP.x	Interrupt Level Priority
0	0	0 (Lowest)
0	1	1
1	0	2
1	1	3 (Highest)

A low-priority interrupt can be interrupted by a high priority interrupt, but not by another low-priority interrupt. A high-priority interrupt can't be interrupted by any other interrupt source.

If two interrupt requests of different priority levels are received simultaneously, the request of higher priority level is serviced. If interrupt requests of the same priority level are received simultaneously, an internal polling sequence determines which request is serviced. Thus within each priority level there is a second priority structure determined by the polling sequence.

Table 10-2. IE Register -- IE - Interrupt Enable Register (A8h)

7	6	5	4	3	2	1	0
EA	-	-	ES	ET1	EX1	ET0	EX0
Bit Number	Bit Mnemonic	Description					
7	EA	Enable All interrupt bit Clear to disable all interrupts. Set to enable all interrupts. If EA=1, each interrupt source is individually enabled or disabled by setting or clearing its own interrupt enable bit.					
6	-	Reserved The value read from this bit is indeterminate. Do not set this bit.					
5	-	Reserved The value read from this bit is indeterminate. Do not set this bit.					
4	ES	Serial port Enable bit Clear to disable serial port interrupt. Set to enable serial port interrupt.					
3	ET1	Timer 1 overflow interrupt Enable bit Clear to disable timer 1 overflow interrupt. Set to enable timer 1 overflow interrupt.					
2	EX1	External interrupt 1 Enable bit Clear to disable external interrupt 1. Set to enable external interrupt 1.					
1	ET0	Timer 0 overflow interrupt Enable bit Clear to disable timer 0 overflow interrupt. Set to enable timer 0 overflow interrupt.					
0	EX0	External interrupt 0 Enable bit Clear to disable external interrupt 0. Set to enable external interrupt 0.					

Reset Value = 0XX0 0000b

Bit addressable

Table 10-3. IP Register -- IP - Interrupt Priority Register (B8h)

7	6	5	4	3	2	1	0
-	-	-	PS	PT1	PX1	PT0	PX0
Bit Number	Bit Mnemonic	Description					
7	-	Reserved The value read from this bit is indeterminate. Do not set this bit.					
6	-	Reserved The value read from this bit is indeterminate. Do not set this bit.					
5	-	Reserved The value read from this bit is indeterminate. Do not set this bit.					
4	PS	Serial port Priority bit Refer to PSH for priority level.					
3	PT1	Timer 1 overflow interrupt Priority bit Refer to PT1H for priority level.					
2	PX1	External interrupt 1 Priority bit Refer to PX1H for priority level.					
1	PT0	Timer 0 overflow interrupt Priority bit Refer to PT0H for priority level.					
0	PX0	External interrupt 0 Priority bit Refer to PX0H for priority level.					

Reset Value = XXX0 0000b

Bit addressable

KTTIC

Table 10-4. IPH Register -- IPH - Interrupt Priority High Register (B7h)

7	6	5	4	3	2	1	0															
-	-	-	PSH	PT1H	PX1H	PT0H	PX0H															
Bit Number	Bit Mnemonic	Description																				
7	-	Reserved The value read from this bit is indeterminate. Do not set this bit.																				
6	-	Reserved The value read from this bit is indeterminate. Do not set this bit.																				
5	-	Reserved The value read from this bit is indeterminate. Do not set this bit.																				
4	PSH	Serial port Priority High bit <table border="1"> <thead> <tr> <th>PSH</th> <th>PS</th> <th>Priority Level</th> </tr> </thead> <tbody> <tr> <td>0</td> <td>0</td> <td>Lowest</td> </tr> <tr> <td>0</td> <td>1</td> <td></td> </tr> <tr> <td>1</td> <td>0</td> <td></td> </tr> <tr> <td>1</td> <td>1</td> <td>Highest</td> </tr> </tbody> </table>						PSH	PS	Priority Level	0	0	Lowest	0	1		1	0		1	1	Highest
PSH	PS	Priority Level																				
0	0	Lowest																				
0	1																					
1	0																					
1	1	Highest																				
3	PT1H	Timer 1 overflow interrupt Priority High bit <table border="1"> <thead> <tr> <th>PT1H</th> <th>PT1</th> <th>Priority Level</th> </tr> </thead> <tbody> <tr> <td>0</td> <td>0</td> <td>Lowest</td> </tr> <tr> <td>0</td> <td>1</td> <td></td> </tr> <tr> <td>1</td> <td>0</td> <td></td> </tr> <tr> <td>1</td> <td>1</td> <td>Highest</td> </tr> </tbody> </table>						PT1H	PT1	Priority Level	0	0	Lowest	0	1		1	0		1	1	Highest
PT1H	PT1	Priority Level																				
0	0	Lowest																				
0	1																					
1	0																					
1	1	Highest																				
2	PX1H	External interrupt 1 Priority High bit <table border="1"> <thead> <tr> <th>PX1H</th> <th>PX1</th> <th>Priority Level</th> </tr> </thead> <tbody> <tr> <td>0</td> <td>0</td> <td>Lowest</td> </tr> <tr> <td>0</td> <td>1</td> <td></td> </tr> <tr> <td>1</td> <td>0</td> <td></td> </tr> <tr> <td>1</td> <td>1</td> <td>Highest</td> </tr> </tbody> </table>						PX1H	PX1	Priority Level	0	0	Lowest	0	1		1	0		1	1	Highest
PX1H	PX1	Priority Level																				
0	0	Lowest																				
0	1																					
1	0																					
1	1	Highest																				
1	PT0H	Timer 0 overflow interrupt Priority High bit <table border="1"> <thead> <tr> <th>PT0H</th> <th>PT0</th> <th>Priority Level</th> </tr> </thead> <tbody> <tr> <td>0</td> <td>0</td> <td>Lowest</td> </tr> <tr> <td>0</td> <td>1</td> <td></td> </tr> <tr> <td>1</td> <td>0</td> <td></td> </tr> <tr> <td>1</td> <td>1</td> <td>Highest</td> </tr> </tbody> </table>						PT0H	PT0	Priority Level	0	0	Lowest	0	1		1	0		1	1	Highest
PT0H	PT0	Priority Level																				
0	0	Lowest																				
0	1																					
1	0																					
1	1	Highest																				
0	PX0H	External interrupt 0 Priority High bit <table border="1"> <thead> <tr> <th>PX0H</th> <th>PX0</th> <th>Priority Level</th> </tr> </thead> <tbody> <tr> <td>0</td> <td>0</td> <td>Lowest</td> </tr> <tr> <td>0</td> <td>1</td> <td></td> </tr> <tr> <td>1</td> <td>0</td> <td></td> </tr> <tr> <td>1</td> <td>1</td> <td>Highest</td> </tr> </tbody> </table>						PX0H	PX0	Priority Level	0	0	Lowest	0	1		1	0		1	1	Highest
PX0H	PX0	Priority Level																				
0	0	Lowest																				
0	1																					
1	0																					
1	1	Highest																				

Reset Value = XXX0 0000b
 Not bit addressable

11. Idle mode

An instruction that sets PCON.0 causes that to be the last instruction executed before going into the Idle mode. In the Idle mode, the internal clock signal is gated off to the CPU, but not to the interrupt, Timer, and Serial Port functions. The CPU status is preserved in its entirety : the Stack Pointer, Program Counter, Program Status Word, Accumulator and all other registers maintain their data during Idle. The port pins hold the logical states they had at the time Idle was activated. ALE and PSEN hold at logic high levels.

There are two ways to terminate the Idle. Activation of any enabled interrupt will cause PCON.0 to be cleared by hardware, terminating the Idle mode. The interrupt will be serviced, and following RETI the next instruction to be executed will be the one following the instruction that put the device into idle.

The flag bits GF0 and GF1 can be used to give an indication if an interrupt occurred during normal operation or during an Idle. For example, an instruction that activates Idle can also set one or both flag bits. When Idle is terminated by an interrupt, the interrupt service routine can examine the flag bits.

The over way of terminating the Idle mode is with a hardware reset. Since the clock oscillator is still running, the hardware reset needs to be held active for only two machine cycles (24 oscillator periods) to complete the reset.

11.1 Power-Down Mode

To save maximum power, a power-down mode can be invoked by software (Refer to Table 9-4., PCON register).

In power-down mode, the oscillator is stopped and the instruction that invoked power-down mode is the last instruction executed. The internal RAM and SFRs retain their value until the power-down mode is terminated. V_{CC} can be lowered to save further power. Either a hardware reset or an external interrupt can cause an exit from power-down. To properly terminate power-down, the reset or external interrupt should not be executed before V_{CC} is restored to its normal operating level and must be held active long enough for the oscillator to restart and stabilize.

Only external interrupts $\overline{INT0}$ and $\overline{INT1}$ are useful to exit from power-down. For that, interrupt must be enabled and configured as level or edge sensitive interrupt input.

Holding the pin low restarts the oscillator but bringing the pin high completes the exit as detailed in Figure 11-1. When both interrupts are enabled, the oscillator restarts as soon as one of the two inputs is held low and power down exit will be completed when the first input will be released. In this case the higher priority interrupt service routine is executed.

Once the interrupt is serviced, the next instruction to be executed after RETI will be the one following the instruction that put TS80C31X2 into power-down mode.

Figure 11-1. Power-Down Exit Waveform

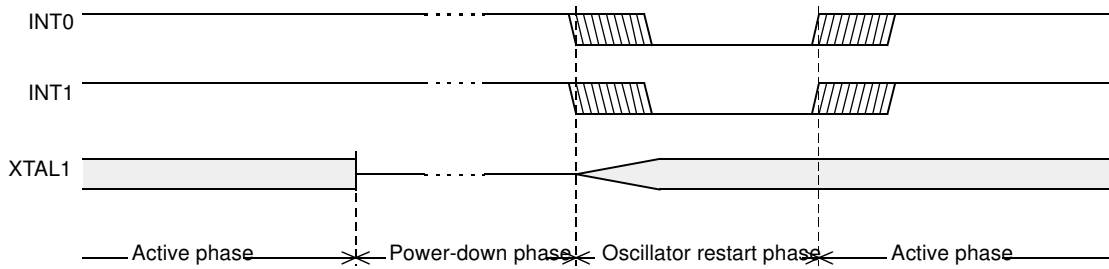

Exit from power-down by reset redefines all the SFRs, exit from power-down by external interrupt does not affect the SFRs.

Exit from power-down by either reset or external interrupt does not affect the internal RAM content.

Note: NOTE: If idle mode is activated with power-down mode (IDL and PD bits set), the exit sequence is unchanged, when execution is vectored to interrupt, PD and IDL bits are cleared and idle mode is not entered.

Table 11-1. The state of ports during idle and power-down modes

Mode	Program Memory	ALE	PSEN	PORT0	PORT1	PORT2	PORT3
Idle	External	1	1	Floating	Port Data	Address	Port Data
Power Down	External	0	0	Floating	Port Data	Port Data	Port Data

KTTIC

12. ONCE™ Mode (ON Chip Emulation)

The ONCE mode facilitates testing and debugging of systems using TS80C31X2 without removing the circuit from the board. The ONCE mode is invoked by driving certain pins of the TS80C31X2; the following sequence must be exercised:

- Pull ALE low while the device is in reset (RST high) and $\overline{\text{PSEN}}$ is high.
- Hold ALE low as RST is deactivated.

While the TS80C31X2 is in ONCE mode, an emulator or test CPU can be used to drive the circuit. Table 26. shows the status of the port pins during ONCE mode.

Normal operation is restored when normal reset is applied.

Table 12-1. External Pin Status during ONCE Mode

ALE	PSEN	Port 0	Port 1	Port 2	Port 3	XTAL1/2
Weak pull-up	Weak pull-up	Float	Weak pull-up	Weak pull-up	Weak pull-up	Active

KTTIC

13. Power-Off Flag

The power-off flag allows the user to distinguish between a “cold start” reset and a “warm start” reset.

A cold start reset is the one induced by V_{CC} switch-on. A warm start reset occurs while V_{CC} is still applied to the device and could be generated for example by an exit from power-down.

The power-off flag (POF) is located in PCON register (See Table 13-1.). POF is set by hardware when V_{CC} rises from 0 to its nominal voltage. The POF can be set or cleared by software allowing the user to determine the type of reset.

The POF value is only relevant with a V_{cc} range from 4.5V to 5.5V. For lower V_{cc} value, reading POF bit will return indeterminate value.

Table 13-1. PCON Register -- PCON - Power Control Register (87h)

7	6	5	4	3	2	1	0
SMOD1	SMOD0	-	POF	GF1	GF0	PD	IDL
Bit Number	Bit Mnemonic	Description					
7	SMOD1	Serial port Mode bit 1 Set to select double baud rate in mode 1, 2 or 3.					
6	SMOD0	Serial port Mode bit 0 Clear to select SM0 bit in SCON register. Set to to select FE bit in SCON register.					
5		Reserved The value read from this bit is indeterminate. Do not set this bit.					
4	POF	Power-Off Flag Clear to recognize next reset type. Set by hardware when V_{CC} rises from 0 to its nominal voltage. Can also be set by software.					
3	GF1	General purpose Flag Cleared by user for general purpose usage. Set by user for general purpose usage.					
2	GF0	General purpose Flag Cleared by user for general purpose usage. Set by user for general purpose usage.					
1	PD	Power-Down mode bit Cleared by hardware when reset occurs. Set to enter power-down mode.					
0	IDL	Idle mode bit Clear by hardware when interrupt or reset occurs. Set to enter idle mode.					

Reset Value = 00X1 0000b

Not bit addressable

14. Electrical Characteristics

14.1 Absolute Maximum Ratings ⁽¹⁾

Ambiant Temperature Under Bias:

C = commercial 0°C to 70°C

I = industrial -40°C to 85°C

Storage Temperature -65°C to + 150°C

Voltage on V_{CC} to V_{SS} -0.5 V to + 7 V

Voltage on V_{PP} to V_{SS} -0.5 V to + 13 V

Voltage on Any Pin to V_{SS} -0.5 V to $V_{CC} + 0.5$ V

Power Dissipation 1 W⁽²⁾

- Note:
1. Stresses at or above those listed under “Absolute Maximum Ratings” may cause permanent damage to the device. This is a stress rating only and functional operation of the device at these or any other conditions above those indicated in the operational sections of this specification is not implied. Exposure to absolute maximum rating conditions may affect device reliability.
 2. This value is based on the maximum allowable die temperature and the thermal resistance of the package.

14.2 Power consumption measurement

Since the introduction of the first C51 devices, every manufacturer made operating Icc measurements under reset, which made sense for the designs where the CPU was running under reset. In Atmel Wireless & Microcontrollers new devices, the CPU is no more active during reset, so the power consumption is very low but is not really representative of what will happen in the customer system. That's why, while keeping measurements under Reset, Atmel Wireless & Microcontrollers presents a new way to measure the operating Icc:

Using an internal test ROM, the following code is executed:

Label: SJMP Label (80 FE)

Ports 1, 2, 3 are disconnected, Port 0 is tied to FFh, EA = Vcc, RST = Vss, XTAL2 is not connected and XTAL1 is driven by the clock.

This is much more representative of the real operating Icc.

14.3 DC Parameters for Standard Voltage

$T_A = 0^\circ\text{C}$ to $+70^\circ\text{C}$; $V_{SS} = 0\text{ V}$; $V_{CC} = 5\text{ V} \pm 10\%$; $F = 0$ to 40 MHz .

$T_A = -40^\circ\text{C}$ to $+85^\circ\text{C}$; $V_{SS} = 0\text{ V}$; $V_{CC} = 5\text{ V} \pm 10\%$; $F = 0$ to 40 MHz .

Table 14-1. DC Parameters in Standard Voltage

Symbol	Parameter	Min	Typ	Max	Unit	Test Conditions
V_{IL}	Input Low Voltage	-0.5		$0.2 V_{CC} - 0.1$	V	
V_{IH}	Input High Voltage except XTAL1, RST	$0.2 V_{CC} + 0.9$		$V_{CC} + 0.5$	V	
V_{IH1}	Input High Voltage, XTAL1, RST	$0.7 V_{CC}$		$V_{CC} + 0.5$	V	
V_{OL}	Output Low Voltage, ports 1, 2, 3 ⁽⁶⁾			0.3 0.45 1.0	V V V	$I_{OL} = 100\ \mu\text{A}^{(4)}$ $I_{OL} = 1.6\ \text{mA}^{(4)}$ $I_{OL} = 3.5\ \text{mA}^{(4)}$
V_{OL1}	Output Low Voltage, port 0 ⁽⁶⁾			0.3 0.45 1.0	V V V	$I_{OL} = 200\ \mu\text{A}^{(4)}$ $I_{OL} = 3.2\ \text{mA}^{(4)}$ $I_{OL} = 7.0\ \text{mA}^{(4)}$
V_{OL2}	Output Low Voltage, ALE, $\overline{\text{PSEN}}$			0.3 0.45 1.0	V V V	$I_{OL} = 100\ \mu\text{A}^{(4)}$ $I_{OL} = 1.6\ \text{mA}^{(4)}$ $I_{OL} = 3.5\ \text{mA}^{(4)}$
V_{OH}	Output High Voltage, ports 1, 2, 3	$V_{CC} - 0.3$ $V_{CC} - 0.7$ $V_{CC} - 1.5$			V V V	$I_{OH} = -10\ \mu\text{A}$ $I_{OH} = -30\ \mu\text{A}$ $I_{OH} = -60\ \mu\text{A}$ $V_{CC} = 5\text{ V} \pm 10\%$
V_{OH1}	Output High Voltage, port 0	$V_{CC} - 0.3$ $V_{CC} - 0.7$ $V_{CC} - 1.5$			V V V	$I_{OH} = -200\ \mu\text{A}$ $I_{OH} = -3.2\ \text{mA}$ $I_{OH} = -7.0\ \text{mA}$ $V_{CC} = 5\text{ V} \pm 10\%$
V_{OH2}	Output High Voltage, ALE, $\overline{\text{PSEN}}$	$V_{CC} - 0.3$ $V_{CC} - 0.7$ $V_{CC} - 1.5$			V V V	$I_{OH} = -100\ \mu\text{A}$ $I_{OH} = -1.6\ \text{mA}$ $I_{OH} = -3.5\ \text{mA}$ $V_{CC} = 5\text{ V} \pm 10\%$
R_{RST}	RST Pulldown Resistor	50	90 ⁽⁵⁾	200	k Ω	
I_{IL}	Logical 0 Input Current ports 1, 2 and 3			-50	μA	$V_{in} = 0.45\text{ V}$
I_{LI}	Input Leakage Current			± 10	μA	$0.45\text{ V} < V_{in} < V_{CC}$
I_{TL}	Logical 1 to 0 Transition Current, ports 1, 2, 3			-650	μA	$V_{in} = 2.0\text{ V}$
C_{IO}	Capacitance of I/O Buffer			10	pF	$F_c = 1\text{ MHz}$ $T_A = 25^\circ\text{C}$
I_{PD}	Power Down Current		20 ⁽⁵⁾	50	μA	$2.0\text{ V} < V_{CC} < 5.5\text{ V}^{(3)}$
I_{CC} under RESET	Power Supply Current Maximum values, X1 mode: ⁽⁷⁾			1 + 0.4 Freq (MHz) @12MHz 5.8 @16MHz 7.4	mA	$V_{CC} = 5.5\text{ V}^{(1)}$
I_{CC} operating	Power Supply Current Maximum values, X1 mode: ⁽⁷⁾			3 + 0.6 Freq (MHz) @12MHz 10.2 @16MHz 12.6	mA	$V_{CC} = 5.5\text{ V}^{(8)}$

Symbol	Parameter	Min	Typ	Max	Unit	Test Conditions
I_{CC} idle	Power Supply Current Maximum values, X1 mode: ⁽⁷⁾			0.25+0.3 Freq (MHz) @12MHz 3.9 @16MHz 5.1	mA	$V_{CC} = 5.5 V^{(2)}$

14.4 DC Parameters for Low Voltage

$T_A = 0^{\circ}C$ to $+70^{\circ}C$; $V_{SS} = 0 V$; $V_{CC} = 2.7 V$ to $5.5 V \pm 10\%$; $F = 0$ to $30 MHz$.

$T_A = -40^{\circ}C$ to $+85^{\circ}C$; $V_{SS} = 0 V$; $V_{CC} = 2.7 V$ to $5.5 V \pm 10\%$; $F = 0$ to $30 MHz$.

Table 14-2. DC Parameters for Low Voltage

Symbol	Parameter	Min	Typ	Max	Unit	Test Conditions
V_{IL}	Input Low Voltage	-0.5		$0.2 V_{CC} - 0.1$	V	
V_{IH}	Input High Voltage except XTAL1, RST	$0.2 V_{CC} + 0.9$		$V_{CC} + 0.5$	V	
V_{IH1}	Input High Voltage, XTAL1, RST	$0.7 V_{CC}$		$V_{CC} + 0.5$	V	
V_{OL}	Output Low Voltage, ports 1, 2, 3 ⁽⁶⁾			0.45	V	$I_{OL} = 0.8 mA^{(4)}$
V_{OL1}	Output Low Voltage, port 0, ALE, \overline{PSEN} ⁽⁶⁾			0.45	V	$I_{OL} = 1.6 mA^{(4)}$
V_{OH}	Output High Voltage, ports 1, 2, 3	$0.9 V_{CC}$			V	$I_{OH} = -10 \mu A$
V_{OH1}	Output High Voltage, port 0, ALE, \overline{PSEN}	$0.9 V_{CC}$			V	$I_{OH} = -40 \mu A$
I_{IL}	Logical 0 Input Current ports 1, 2 and 3			-50	μA	$V_{in} = 0.45 V$
I_{LI}	Input Leakage Current			± 10	μA	$0.45 V < V_{in} < V_{CC}$
I_{TL}	Logical 1 to 0 Transition Current, ports 1, 2, 3			-650	μA	$V_{in} = 2.0 V$
R_{RST}	RST Pulldown Resistor	50	90 ⁽⁵⁾	200	k Ω	
CIO	Capacitance of I/O Buffer			10	pF	$F_c = 1 MHz$ $T_A = 25^{\circ}C$
I_{PD}	Power Down Current		20 ⁽⁵⁾ 10 ⁽⁵⁾	50 30	μA	$V_{CC} = 2.0 V$ to $5.5 V^{(3)}$ $V_{CC} = 2.0 V$ to $3.3 V^{(3)}$
I_{CC} under RESET	Power Supply Current Maximum values, X1 mode: ⁽⁷⁾			1 + 0.2 Freq (MHz) @12MHz 3.4 @16MHz 4.2	mA	$V_{CC} = 3.3 V^{(1)}$
I_{CC} operating	Power Supply Current Maximum values, X1 mode: ⁽⁷⁾			1 + 0.3 Freq (MHz) @12MHz 4.6 @16MHz 5.8	mA	$V_{CC} = 3.3 V^{(8)}$
I_{CC} idle	Power Supply Current Maximum values, X1 mode: ⁽⁷⁾			0.15 Freq (MHz) + 0.2 @12MHz 2 @16MHz 2.6	mA	$V_{CC} = 3.3 V^{(2)}$

Note: 1. I_{CC} under reset is measured with all output pins disconnected; XTAL1 driven with T_{CLCH} , $T_{CHCL} = 5 ns$ (see Figure 14-5.), $V_{IL} = V_{SS} + 0.5 V$,



- $V_{IH} = V_{CC} - 0.5V$; XTAL2 N.C.; $\overline{EA} = RST = Port\ 0 = V_{CC}$. I_{CC} would be slightly higher if a crystal oscillator used..
- Idle I_{CC} is measured with all output pins disconnected; XTAL1 driven with T_{CLCH} , $T_{CHCL} = 5\ ns$, $V_{IL} = V_{SS} + 0.5\ V$, $V_{IH} = V_{CC} - 0.5\ V$; XTAL2 N.C.; Port 0 = V_{CC} ; $\overline{EA} = RST = V_{SS}$ (see Figure 14-3.).
 - Power Down I_{CC} is measured with all output pins disconnected; $\overline{EA} = V_{SS}$, PORT 0 = V_{CC} ; XTAL2 NC.; RST = V_{SS} (see Figure 14-4.).
 - Capacitance loading on Ports 0 and 2 may cause spurious noise pulses to be superimposed on the V_{OL} s of ALE and Ports 1 and 3. The noise is due to external bus capacitance discharging into the Port 0 and Port 2 pins when these pins make 1 to 0 transitions during bus operation. In the worst cases (capacitive loading 100pF), the noise pulse on the ALE line may exceed 0.45V with maxi V_{OL} peak 0.6V. A Schmitt Trigger use is not necessary.
 - Typicals are based on a limited number of samples and are not guaranteed. The values listed are at room temperature and 5V.
 - Under steady state (non-transient) conditions, I_{OL} must be externally limited as follows:
 Maximum I_{OL} per port pin: 10 mA
 Maximum I_{OL} per 8-bit port:
 Port 0: 26 mA
 Ports 1, 2 and 3: 15 mA
 Maximum total I_{OL} for all output pins: 71 mA
 If I_{OL} exceeds the test condition, V_{OL} may exceed the related specification. Pins are not guaranteed to sink current greater than the listed test conditions.
 - For other values, please contact your sales office.
 - Operating I_{CC} is measured with all output pins disconnected; XTAL1 driven with T_{CLCH} , $T_{CHCL} = 5\ ns$ (see Figure 14-5.), $V_{IL} = V_{SS} + 0.5\ V$, $V_{IH} = V_{CC} - 0.5V$; XTAL2 N.C.; $\overline{EA} = Port\ 0 = V_{CC}$; RST = V_{SS} . The internal ROM runs the code 80 FE (label: SJMP label). I_{CC} would be slightly higher if a crystal oscillator is used. Measurements are made with OTP products when possible, which is the worst case.

KTTIC

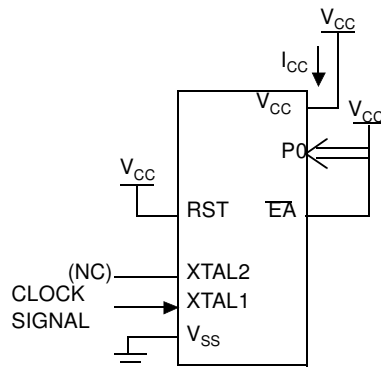

All other pins are disconnected.

Figure 14-1. I_{CC} Test Condition, under reset

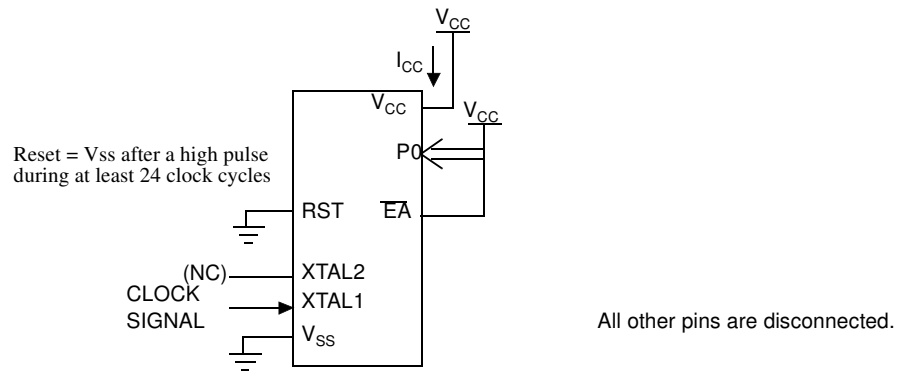

Figure 14-2. Operating I_{CC} Test Condition

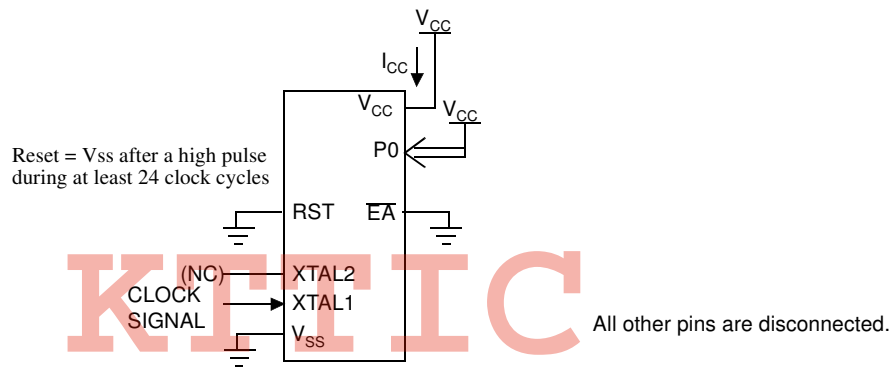

Figure 14-3. I_{CC} Test Condition, Idle Mode

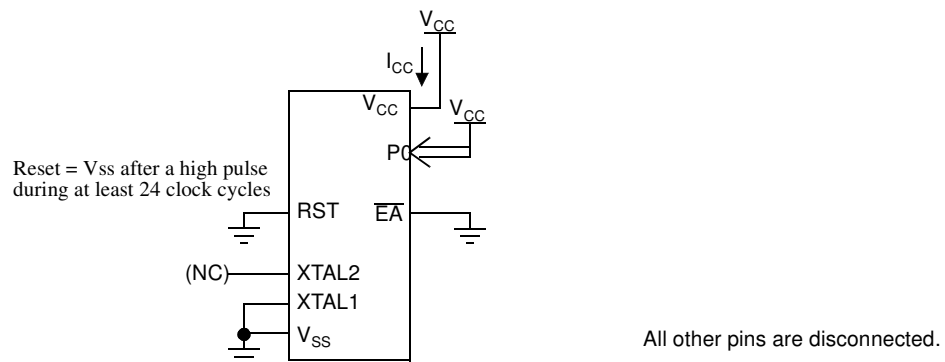

Figure 14-4. I_{CC} Test Condition, Power-Down Mode

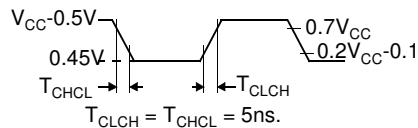

Figure 14-5. Clock Signal Waveform for I_{CC} Tests in Active and Idle Modes

14.5 AC Parameters

14.5.1 Explanation of the AC Symbols

Each timing symbol has 5 characters. The first character is always a “T” (stands for time). The other characters, depending on their positions, stand for the name of a signal or the logical status of that signal. The following is a list of all the characters and what they stand for.

Example: T_{AVLL} = Time for Address Valid to ALE Low.

T_{LLPL} = Time for ALE Low to \overline{PSEN} Low.

$T_A = 0$ to $+70^\circ\text{C}$ (commercial temperature range); $V_{SS} = 0\text{ V}$; $V_{CC} = 5\text{ V} \pm 10\%$; -M and -V ranges.
 $T_A = -40^\circ\text{C}$ to $+85^\circ\text{C}$ (industrial temperature range); $V_{SS} = 0\text{ V}$; $V_{CC} = 5\text{ V} \pm 10\%$; -M and -V ranges.

$T_A = 0$ to $+70^\circ\text{C}$ (commercial temperature range); $V_{SS} = 0\text{ V}$; $2.7\text{ V} < V_{CC} < 5.5\text{ V}$; -L range.

$T_A = -40^\circ\text{C}$ to $+85^\circ\text{C}$ (industrial temperature range); $V_{SS} = 0\text{ V}$; $2.7\text{ V} < V_{CC} < 5.5\text{ V}$; -L range.

Table 14-3. gives the maximum applicable load capacitance for Port 0, Port 1, 2 and 3, and ALE and \overline{PSEN} signals. Timings will be guaranteed if these capacitances are respected. Higher capacitance values can be used, but timings will then be degraded.

Table 14-3. Load Capacitance versus speed range, in pF

	-M	-V	-L
Port 0	100	50	100
Port 1, 2, 3	80	50	80
ALE / \overline{PSEN}	100	30	100

Table 8-5., Table 8-8. and Table 8-11. give the description of each AC symbols.

Table 14-6., Table 14-9. and Table 14-12. give for each range the AC parameter.

Table 14-7., Table 14-10. and Table 14-13. give the frequency derating formula of the AC parameter. To calculate each AC symbols, take the x value corresponding to the speed grade you need (-M, -V or -L) and replace this value in the formula. Values of the frequency must be limited to the corresponding speed grade:

Table 14-4. Max frequency for derating formula regarding the speed grade

	-M X1 mode	-M X2 mode	-V X1 mode	-V X2 mode	-L X1 mode	-L X2 mode
Freq (MHz)	40	20	40	30	30	20
T (ns)	25	50	25	33.3	33.3	50

Example:

T_{LLIV} in X2 mode for a -V part at 20 MHz ($T = 1/20^{E6} = 50$ ns):

$x = 25$ (Table 14-7.)

$T = 50$ ns

$T_{LLIV} = 2T - x = 2 \times 50 - 25 = 75$ ns

Table 14-5. External Program Memory Characteristics

Symbol	Parameter
T	Oscillator clock period
T_{LHLL}	ALE pulse width
T_{AVLL}	Address Valid to ALE
T_{LLAX}	Address Hold After ALE
T_{LLIV}	ALE to Valid Instruction In
T_{LLPL}	ALE to \overline{PSEN}
T_{PLPH}	\overline{PSEN} Pulse Width
T_{PLIV}	\overline{PSEN} to Valid Instruction In
T_{PXIX}	Input Instruction Hold After \overline{PSEN}
T_{PXIZ}	Input Instruction Float After \overline{PSEN}
T_{PXAV}	\overline{PSEN} to Address Valid
T_{AVIV}	Address to Valid Instruction In
T_{PLAZ}	\overline{PSEN} Low to Address Float

Table 14-6. AC Parameters for Fix Clock

Speed	-M 40 MHz		-V X2 mode 30 MHz 60 MHz equiv.		-V standard mode 40 MHz		-L X2 mode 20 MHz 40 MHz equiv.		-L standard mode 30 MHz		Units
	Min	Max	Min	Max	Min	Max	Min	Max	Min	Max	
T	25		33		25		50		33		ns
T _{LHLL}	40		25		42		35		52		ns
T _{AVLL}	10		4		12		5		13		ns
T _{LLAX}	10		4		12		5		13		ns
T _{LLIV}		70		45		78		65		98	ns
T _{LLPL}	15		9		17		10		18		ns
T _{PLPH}	55		35		60		50		75		ns
T _{PLIV}		35		25		50		30		55	ns
T _{PXIX}	0		0		0		0		0		ns
T _{PXIZ}		18		12		20		10		18	ns
T _{AVIV}		85		53		95		80		122	ns
T _{PLAZ}		10		10		10		10		10	ns

Table 14-7. AC Parameters for a Variable Clock: derating formula

Symbol	Type	Standard Clock	X2 Clock	-M	-V	-L	Units
T _{LHLL}	Min	2 T - x	T - x	10	8	15	ns
T _{AVLL}	Min	T - x	0.5 T - x	15	13	20	ns
T _{LLAX}	Min	T - x	0.5 T - x	15	13	20	ns
T _{LLIV}	Max	4 T - x	2 T - x	30	22	35	ns
T _{LLPL}	Min	T - x	0.5 T - x	10	8	15	ns
T _{PLPH}	Min	3 T - x	1.5 T - x	20	15	25	ns
T _{PLIV}	Max	3 T - x	1.5 T - x	40	25	45	ns
T _{PXIX}	Min	x	x	0	0	0	ns
T _{PXIZ}	Max	T - x	0.5 T - x	7	5	15	ns
T _{AVIV}	Max	5 T - x	2.5 T - x	40	30	45	ns
T _{PLAZ}	Max	x	x	10	10	10	ns

14.5.2 External Program Memory Read Cycle

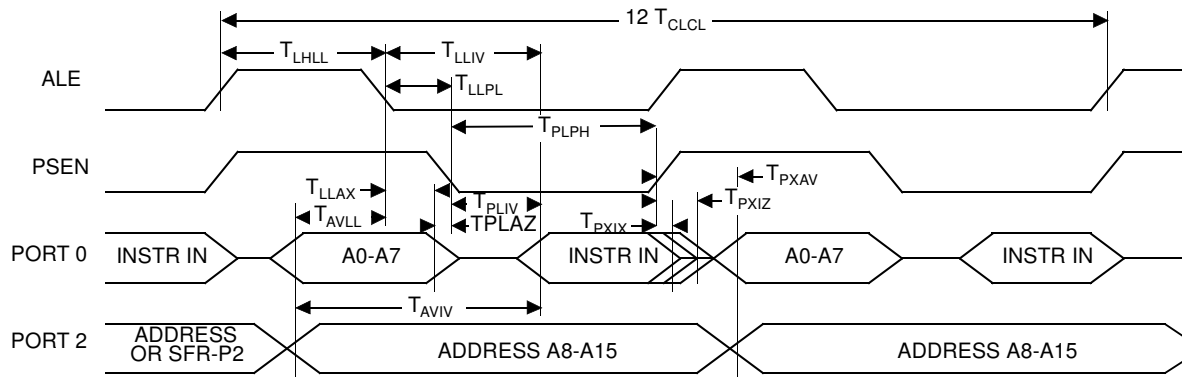

Figure 14-6. External Program Memory Read Cycle

Table 14-8. External Data Memory Characteristics

Symbol	Parameter
T _{RLRH}	\overline{RD} Pulse Width
T _{WLWH}	\overline{WR} Pulse Width
T _{RLDV}	\overline{RD} to Valid Data In
T _{RHDX}	Data Hold After \overline{RD}
T _{RHDZ}	Data Float After \overline{RD}
T _{LLDV}	ALE to Valid Data In
T _{AVDV}	Address to Valid Data In
T _{LLWL}	ALE to \overline{WR} or \overline{RD}
T _{AVWL}	Address to \overline{WR} or \overline{RD}
T _{QVWX}	Data Valid to \overline{WR} Transition
T _{QVWH}	Data set-up to \overline{WR} High
T _{WHQX}	Data Hold After \overline{WR}
T _{RLAZ}	\overline{RD} Low to Address Float
T _{WHLH}	\overline{RD} or \overline{WR} High to ALE high

Table 14-9. AC Parameters for a Fix Clock

Speed	-M 40 MHz		-V X2 mode 30 MHz 60 MHz equiv.		-V standard mode 40 MHz		-L X2 mode 20 MHz 40 MHz equiv.		-L standard mode 30 MHz		Units
	Min	Max	Min	Max	Min	Max	Min	Max	Min	Max	
T _{RLRH}	130		85		135		125		175		ns
T _{WLWH}	130		85		135		125		175		ns
T _{RLDV}		100		60		102		95		137	ns
T _{RHDX}	0		0		0		0		0		ns
T _{RHDZ}		30		18		35		25		42	ns
T _{LLDV}		160		98		165		155		222	ns
T _{AVDV}		165		100		175		160		235	ns
T _{LLWL}	50	100	30	70	55	95	45	105	70	130	ns
T _{AVWL}	75		47		80		70		103		ns
T _{QWX}	10		7		15		5		13		ns
T _{QWH}	160		107		165		155		213		ns
T _{WHQX}	15		9		17		10		18		ns
T _{RLAZ}		0		0		0		0		0	ns
T _{WHLH}	10	40	7	27	15	35	5	45	13	53	ns

KTTIC

Table 14-10. AC Parameters for a Variable Clock: derating formula

Symbol	Type	Standard Clock	X2 Clock	-M	-V	-L	Units
T_{RLRH}	Min	6 T - x	3 T - x	20	15	25	ns
T_{WLWH}	Min	6 T - x	3 T - x	20	15	25	ns
T_{RLDV}	Max	5 T - x	2.5 T - x	25	23	30	ns
T_{RHDx}	Min	x	x	0	0	0	ns
T_{RHDz}	Max	2 T - x	T - x	20	15	25	ns
T_{LLDV}	Max	8 T - x	4T - x	40	35	45	ns
T_{AVDV}	Max	9 T - x	4.5 T - x	60	50	65	ns
T_{LLWL}	Min	3 T - x	1.5 T - x	25	20	30	ns
T_{LLWL}	Max	3 T + x	1.5 T + x	25	20	30	ns
T_{AVWL}	Min	4 T - x	2 T - x	25	20	30	ns
T_{QVWX}	Min	T - x	0.5 T - x	15	10	20	ns
T_{QVWH}	Min	7 T - x	3.5 T - x	15	10	20	ns
T_{WHQX}	Min	T - x	0.5 T - x	10	8	15	ns
T_{RLAZ}	Max	x	x	0	0	0	ns
T_{WHLH}	Min	T - x	0.5 T - x	15	10	20	ns
T_{WHLH}	Max	T + x	0.5 T + x	15	10	20	ns

14.5.3 External Data Memory Write Cycle

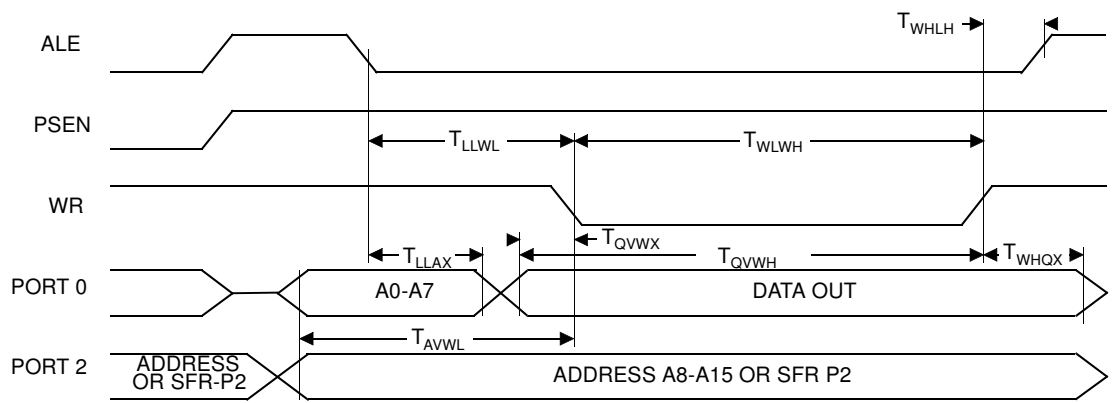

Figure 14-7. External Data Memory Write Cycle

14.5.4 External Data Memory Read Cycle

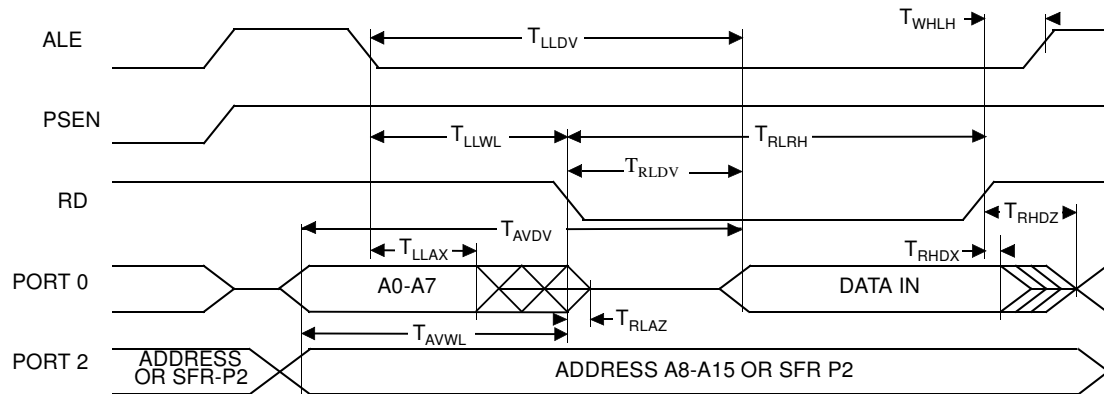

Figure 14-8. External Data Memory Read Cycle

Table 14-11. Serial Port Timing - Shift Register Mode

Symbol	Parameter
T_{XLXL}	Serial port clock cycle time
T_{QVHX}	Output data set-up to clock rising edge
T_{XHGX}	Output data hold after clock rising edge
T_{XHDX}	Input data hold after clock rising edge
T_{XHDV}	Clock rising edge to input data valid

Table 14-12. AC Parameters for a Fix Clock

Speed	-M 40 MHz		-V X2 mode 30 MHz 60 MHz equiv.		-V standard mode 40 MHz		-L X2 mode 20 MHz 40 MHz equiv.		-L standard mode 30 MHz		Units
	Min	Max	Min	Max	Min	Max	Min	Max	Min	Max	
T_{XLXL}	300		200		300		300		400		ns
T_{QVHX}	200		117		200		200		283		ns
T_{XHGX}	30		13		30		30		47		ns
T_{XHDX}	0		0		0		0		0		ns
T_{XHDV}		117		34		117		117		200	ns

Table 14-13. AC Parameters for a Variable Clock: derating formula

Symbol	Type	Standard Clock	X2 Clock	-M	-V	-L	Units
T_{XLXL}	Min	12 T	6 T				ns
T_{QVHX}	Min	10 T - x	5 T - x	50	50	50	ns
T_{XHGX}	Min	2 T - x	T - x	20	20	20	ns
T_{XHDX}	Min	x	x	0	0	0	ns
T_{XHDV}	Max	10 T - x	5 T - x	133	133	133	ns

14.5.5 Shift Register Timing Waveforms

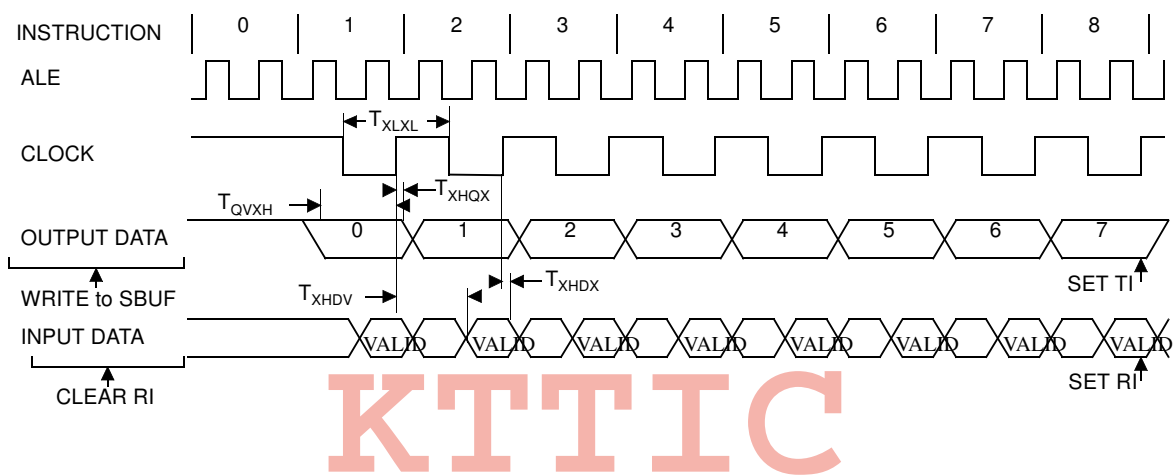

Figure 14-9. Shift Register Timing Waveforms

Table 14-14. External Clock Drive Characteristics (XTAL1)

Symbol	Parameter	Min	Max	Units
T_{CLCL}	Oscillator Period	25		ns
T_{CHCX}	High Time	5		ns
T_{CLCX}	Low Time	5		ns
T_{CLCH}	Rise Time		5	ns
T_{CHCL}	Fall Time		5	ns
T_{CHCX}/T_{CLCX}	Cyclic ratio in X2 mode	40	60	%

14.5.6 External Clock Drive Waveforms

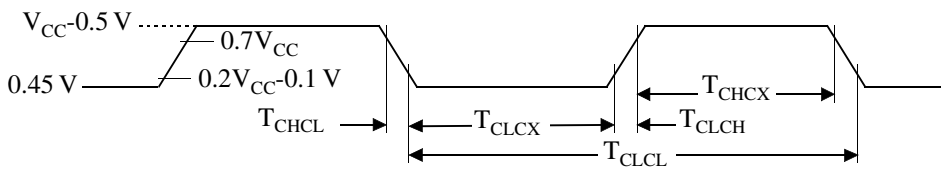

Figure 14-10. External Clock Drive Waveforms

14.5.7 AC Testing Input/Output Waveforms

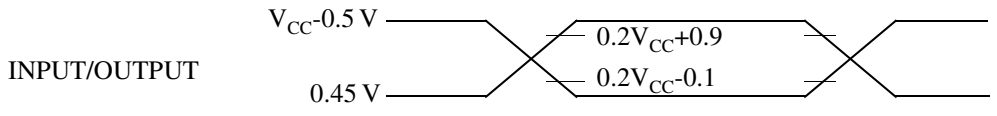

Figure 14-11. AC Testing Input/Output Waveforms

AC inputs during testing are driven at $V_{CC} - 0.5$ for a logic “1” and 0.45V for a logic “0”. Timing measurement are made at V_{IH} min for a logic “1” and V_{IL} max for a logic “0”.

14.5.8 Float Waveforms

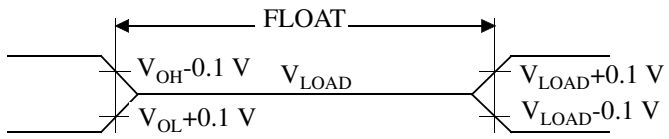

Figure 14-12. Float Waveforms

For timing purposes a port pin is no longer floating when a 100 mV change from load voltage occurs and begins to float when a 100 mV change from the loaded V_{OH}/V_{OL} level occurs. $I_{OL}/I_{OH} \geq \pm 20mA$.

14.5.9 Clock Waveforms

Valid in normal clock mode. In X2 mode XTAL2 signal must be changed to XTAL2 divided by two.

Figure 14-13. Clock Waveforms

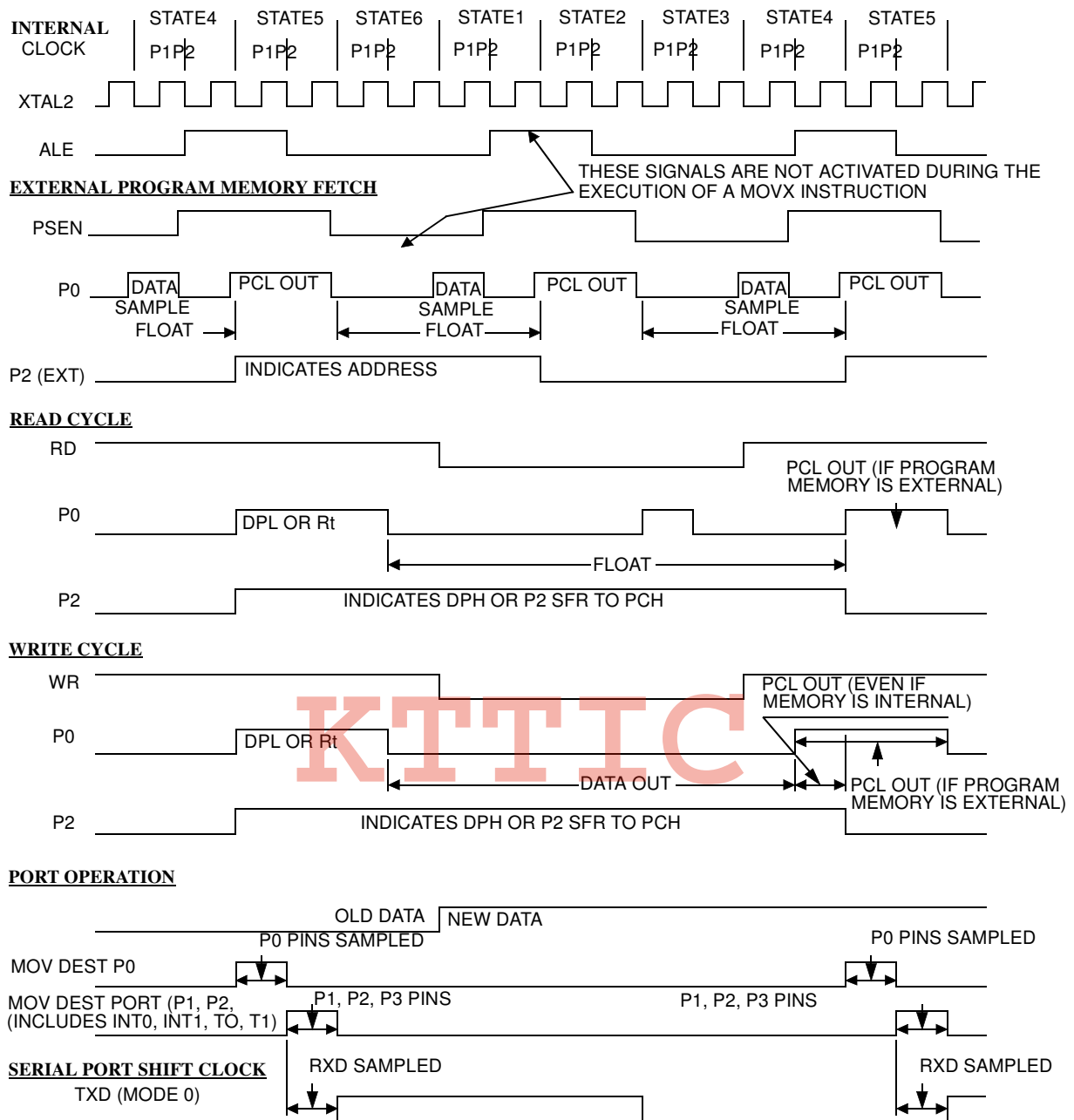

This diagram indicates when signals are clocked internally. The time it takes the signals to propagate to the pins, however, ranges from 25 to 125 ns. This propagation delay is dependent on variables such as temperature and pin loading. Propagation also varies from output to output and component. Typically though ($T_A=25^{\circ}\text{C}$ fully loaded) $\overline{\text{RD}}$ and $\overline{\text{WR}}$ propagation delays are approximately 50ns. The other signals are typically 85 ns. Propagation delays are incorporated in the AC specifications.

15. Ordering Information

Part Number ⁽³⁾	Memory Size	Supply Voltage	Temperature Range	Max Frequency	Package	Packing
TS80C31X2-MCA						
TS80C31X2-MCB						
TS80C31X2-MCC						
TS80C31X2-MCE						
TS80C31X2-LCA						
TS80C31X2-LCB						
TS80C31X2-LCC						
TS80C31X2-LCE						
TS80C31X2-VCA						
TS80C31X2-VCB						
TS80C31X2-VCC						
TS80C31X2-VCE						
TS80C31X2-MIA						
TS80C31X2-MIB						
TS80C31X2-MIC						
TS80C31X2-MIE						
TS80C31X2-LIA						
TS80C31X2-LIB						
TS80C31X2-LIC						
TS80C31X2-LIE						
TS80C31X2-VIA						
TS80C31X2-VIB						
TS80C31X2-VIC						
TS80C31X2-VIE						
AT80C31X2-3CSUM	ROMLess	5V ±10%	Industrial & Green	40 MHz ⁽¹⁾	PDIL40	Stick
AT80C31X2-SLSUM	ROMLess	5V ±10%	Industrial & Green	40 MHz ⁽¹⁾	PLCC44	Stick
AT80C31X2-RLTUM	ROMLess	5V ±10%	Industrial & Green	40 MHz ⁽¹⁾	VQFP44	Tray
AT80C31X2-3CSUL	ROMLess	2.7 to 5.5V	Industrial & Green	30 MHz ⁽¹⁾	PDIL40	Stick
AT80C31X2-SLSUL	ROMLess	2.7 to 5.5V	Industrial & Green	30 MHz ⁽¹⁾	PLCC44	Stick
AT80C31X2-RLTUL	ROMLess	2.7 to 5.5V	Industrial & Green	30 MHz ⁽¹⁾	VQFP44	Tray

OBSOLETE

KTTIC

Part Number ⁽³⁾	Memory Size	Supply Voltage	Temperature Range	Max Frequency	Package	Packing
AT80C31X2-3CSUV	ROMLess	5V \pm 10%	Industrial & Green	60 MHz ⁽³⁾	PDIL40	Stick
AT80C31X2-SLSUV	ROMLess	5V \pm 10%	Industrial & Green	60 MHz ⁽³⁾	PLCC44	Stick
AT80C31X2-RLTUV	ROMLess	5V \pm 10%	Industrial & Green	60 MHz ⁽³⁾	VQFP44	Tray

- Notes:
1. 20 MHz in X2 Mode.
 2. Tape and Reel available for SL, PQFP and RL packages.
 3. 30 MHz in X2 Mode.

KTTIC



Atmel Corporation

2325 Orchard Parkway
San Jose, CA 95131, USA
Tel: 1(408) 441-0311
Fax: 1(408) 487-2600

Regional Headquarters

Europe

Atmel Sarl
Route des Arsenalux 41
Case Postale 80
CH-1705 Fribourg
Switzerland
Tel: (41) 26-426-5555
Fax: (41) 26-426-5500

Asia

Room 1219
Chinachem Golden Plaza
77 Mody Road Tsimshatsui
East Kowloon
Hong Kong
Tel: (852) 2721-9778
Fax: (852) 2722-1369

Japan

9F, Tonetsu Shinkawa Bldg.
1-24-8 Shinkawa
Chuo-ku, Tokyo 104-0033
Japan
Tel: (81) 3-3523-3551
Fax: (81) 3-3523-7581

Atmel Operations

Memory

2325 Orchard Parkway
San Jose, CA 95131, USA
Tel: 1(408) 441-0311
Fax: 1(408) 436-4314

Microcontrollers

2325 Orchard Parkway
San Jose, CA 95131, USA
Tel: 1(408) 441-0311
Fax: 1(408) 436-4314

La Chantrerie
BP 70602
44306 Nantes Cedex 3, France
Tel: (33) 2-40-18-18-18
Fax: (33) 2-40-18-19-60

ASIC/ASSP/Smart Cards

Zone Industrielle
13106 Rousset Cedex, France
Tel: (33) 4-42-53-60-00
Fax: (33) 4-42-53-60-01

1150 East Cheyenne Mtn. Blvd.
Colorado Springs, CO 80906, USA
Tel: 1(719) 576-3300
Fax: 1(719) 540-1759

Scottish Enterprise Technology Park
Maxwell Building
East Kilbride G75 0QR, Scotland
Tel: (44) 1355-803-000
Fax: (44) 1355-242-743

RF/Automotive

Theresienstrasse 2
Postfach 3535
74025 Heilbronn, Germany
Tel: (49) 71-31-67-0
Fax: (49) 71-31-67-2340

1150 East Cheyenne Mtn. Blvd.
Colorado Springs, CO 80906, USA
Tel: 1(719) 576-3300
Fax: 1(719) 540-1759

Biometrics/Imaging/Hi-Rel MPU/ High Speed Converters/RF Datacom

Avenue de Rochepleine
BP 123
38521 Saint-Egreve Cedex, France
Tel: (33) 4-76-58-30-00
Fax: (33) 4-76-58-34-80

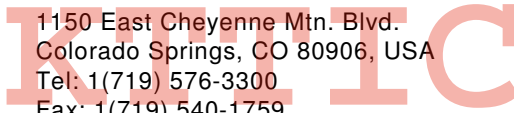

Literature Requests

www.atmel.com/literature

Disclaimer: The information in this document is provided in connection with Atmel products. No license, express or implied, by estoppel or otherwise, to any intellectual property right is granted by this document or in connection with the sale of Atmel products. **EXCEPT AS SET FORTH IN ATMEL'S TERMS AND CONDITIONS OF SALE LOCATED ON ATMEL'S WEB SITE, ATMEL ASSUMES NO LIABILITY WHATSOEVER AND DISCLAIMS ANY EXPRESS, IMPLIED OR STATUTORY WARRANTY RELATING TO ITS PRODUCTS INCLUDING, BUT NOT LIMITED TO, THE IMPLIED WARRANTY OF MERCHANTABILITY, FITNESS FOR A PARTICULAR PURPOSE, OR NON-INFRINGEMENT. IN NO EVENT SHALL ATMEL BE LIABLE FOR ANY DIRECT, INDIRECT, CONSEQUENTIAL, PUNITIVE, SPECIAL OR INCIDENTAL DAMAGES (INCLUDING, WITHOUT LIMITATION, DAMAGES FOR LOSS OF PROFITS, BUSINESS INTERRUPTION, OR LOSS OF INFORMATION) ARISING OUT OF THE USE OR INABILITY TO USE THIS DOCUMENT, EVEN IF ATMEL HAS BEEN ADVISED OF THE POSSIBILITY OF SUCH DAMAGES.** Atmel makes no representations or warranties with respect to the accuracy or completeness of the contents of this document and reserves the right to make changes to specifications and product descriptions at any time without notice. Atmel does not make any commitment to update the information contained herein. Unless specifically provided otherwise, Atmel products are not suitable for, and shall not be used in, automotive applications. Atmel's products are not intended, authorized, or warranted for use as components in applications intended to support or sustain life.

© Atmel Corporation 2008. All rights reserved. Atmel®, logo and combinations thereof, are registered trademarks, and Everywhere You Are® are the trademarks of Atmel Corporation or its subsidiaries. Other terms and product names may be trademarks of others.



Printed on recycled paper.