

Features

- High Performance, Low Power AVR[®] 8-bit Microcontroller
- Advanced RISC Architecture
 - 129 Powerful Instructions - Most Single Clock Cycle Execution
 - 32 x 8 General Purpose Working Registers
 - Fully Static Operation
 - Up to 1 MIPS throughput per MHz
 - On-chip 2-cycle Multiplier
- Data and Non-Volatile Program Memory
 - 8K Bytes Flash of In-System Programmable Program Memory
 - Endurance: 10,000 Write/Erase Cycles
 - Optional Boot Code Section with Independent Lock Bits
- In-System Programming by On-chip Boot Program
- True Read-While-Write Operation
 - 512 Bytes of In-System Programmable EEPROM
- Endurance: 100,000 Write/Erase Cycles
 - 512 Bytes Internal SRAM
 - Programming Lock for Flash Program and EEPROM Data Security
- On Chip Debug Interface (debugWIRE)
- Peripheral Features
 - Two or three 12-bit High Speed PSC (Power Stage Controllers) with 4-bit Resolution Enhancement
 - Non Overlapping Inverted PWM Output Pins With Flexible Dead-Time
 - Variable PWM duty Cycle and Frequency
 - Synchronous Update of all PWM Registers
 - Auto Stop Function for Event Driven PFC Implementation
 - Less than 25 Hz Step Width at 150 kHz Output Frequency
 - PSC2 with four Output Pins and Output Matrix
 - One 8-bit General purpose Timer/Counter with Separate Prescaler and Capture Mode
 - One 16-bit General purpose Timer/Counter with Separate Prescaler, Compare Mode and Capture Mode
 - Programmable Serial USART
 - Standard UART mode
 - 16/17 bit Biphase Mode for DALI Communications
 - Master/Slave SPI Serial Interface
 - 10-bit ADC
 - Up To 11 Single Ended Channels and 2 Fully Differential ADC Channel Pairs
 - Programmable Gain (5x, 10x, 20x, 40x on Differential Channels)
 - Internal Reference Voltage
 - 10-bit DAC
 - Two or three Analog Comparator with Resistor-Array to Adjust Comparison Voltage
 - 4 External Interrupts
 - Programmable Watchdog Timer with Separate On-Chip Oscillator
- Special Microcontroller Features
 - Low Power Idle, Noise Reduction, and Power Down Modes
 - Power On Reset and Programmable Brown Out Detection
 - Flag Array in Bit-programmable I/O Space (4 bytes)



8-bit **AVR[®]**
Microcontroller
with 8K Bytes
In-System
Programmable
Flash

AT90PWM2
AT90PWM3

AT90PWM2B
AT90PWM3B

Summary

4317IS-AVR-01/08



- In-System Programmable via SPI Port
- Internal Calibrated RC Oscillator (8 MHz)
- On-chip PLL for fast PWM (32 MHz, 64 MHz) and CPU (16 MHz)
- Operating Voltage: 2.7V - 5.5V
- Extended Operating Temperature:
 - -40°C to +105°

| Product | Package | 12 bit PWM with deadtime | ADC Input | ADC Diff | Analog Compar | Application |
|-----------------------|----------------|-----------------------------|--------------|-------------|------------------|--|
| AT90PWM2 AT90PWM2B | SO24 | 2 x 2 | 8 | 1 | 2 | One fluorescent ballast |
| AT90PWM3 AT90PWM3B | SO32, QFN32 | 3 x 2 | 11 | 2 | 3 | HID ballast, fluorescent ballast, Motor control |

1. History

| Product | Revision |
|------------------------|--|
| AT90PWM2 AT90PWM3 | First revision of parts, only for running production. |
| AT90PWM2B AT90PWM3B | Second revision of parts, for all new developments. The major changes are : <ul style="list-style-type: none"> • complement the PSCOUT01, PSCOUT11, PSCOUT21 polarity in centered mode - See "PSCn0 & PSCn1 Basic Waveforms in Center Aligned Mode" on page 139. • Add the PSC software triggering capture - See "PSC 0 Input Capture Register – PICR0H and PICR0L" on page 170. • Add bits to read the PSC output activity - See "PSC0 Interrupt Flag Register – PIFR0" on page 172. • Add some clock configurations - See "Device Clocking Options Select AT90PWM2B/3B" on page 31. • Change Amplifier Synchronization - See "Amplifier" on page 252. and See "" on page 254. • Correction of the Errata - See "Errata" on page 23. |

This datasheet deals with product characteristics of AT90PW2 and AT90WM3. It will be updated as soon as characterization will be done.

2. Disclaimer

Typical values contained in this datasheet are based on simulations and characterization of other AVR microcontrollers manufactured on the same process technology. Min and Max values will be available after the device is characterized.

3. Pin Configurations

Figure 3-1. SOIC 24-pin Package

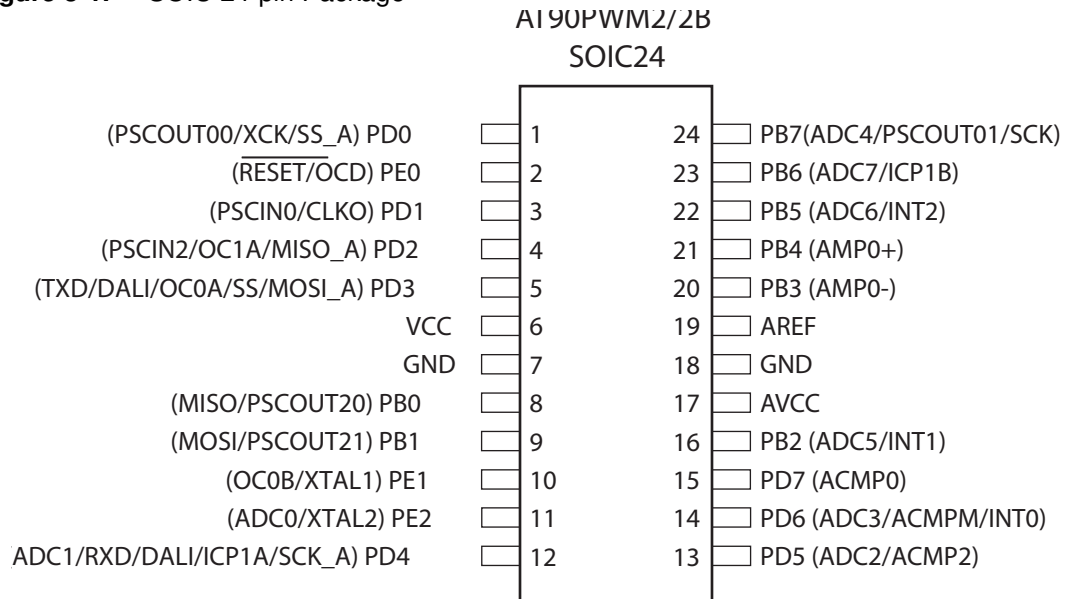

Figure 3-2. SOIC 32-pin Package

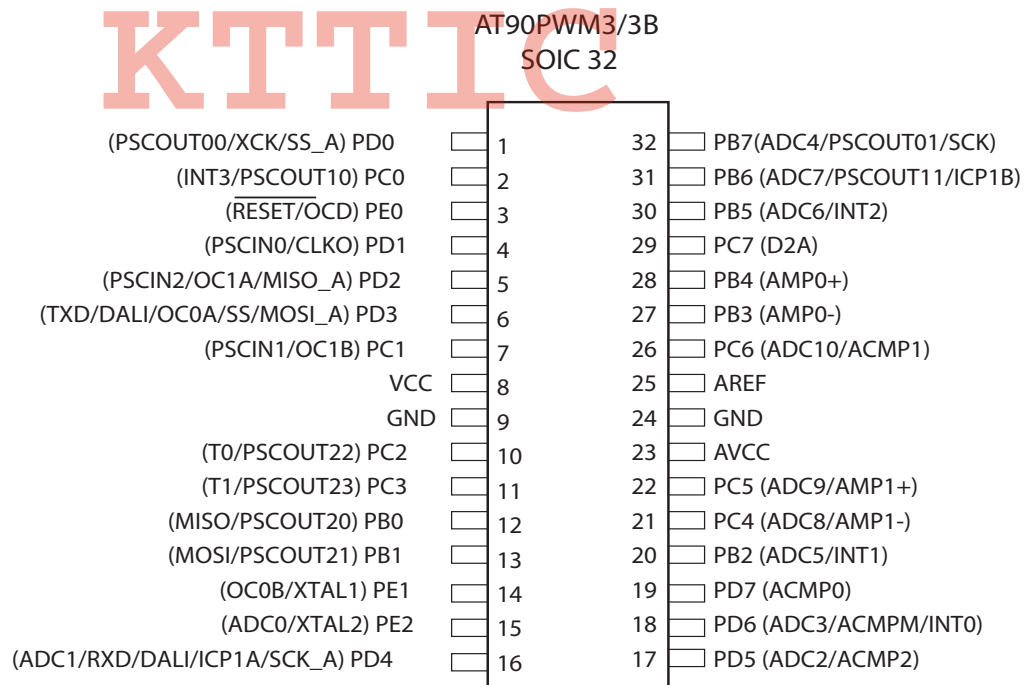
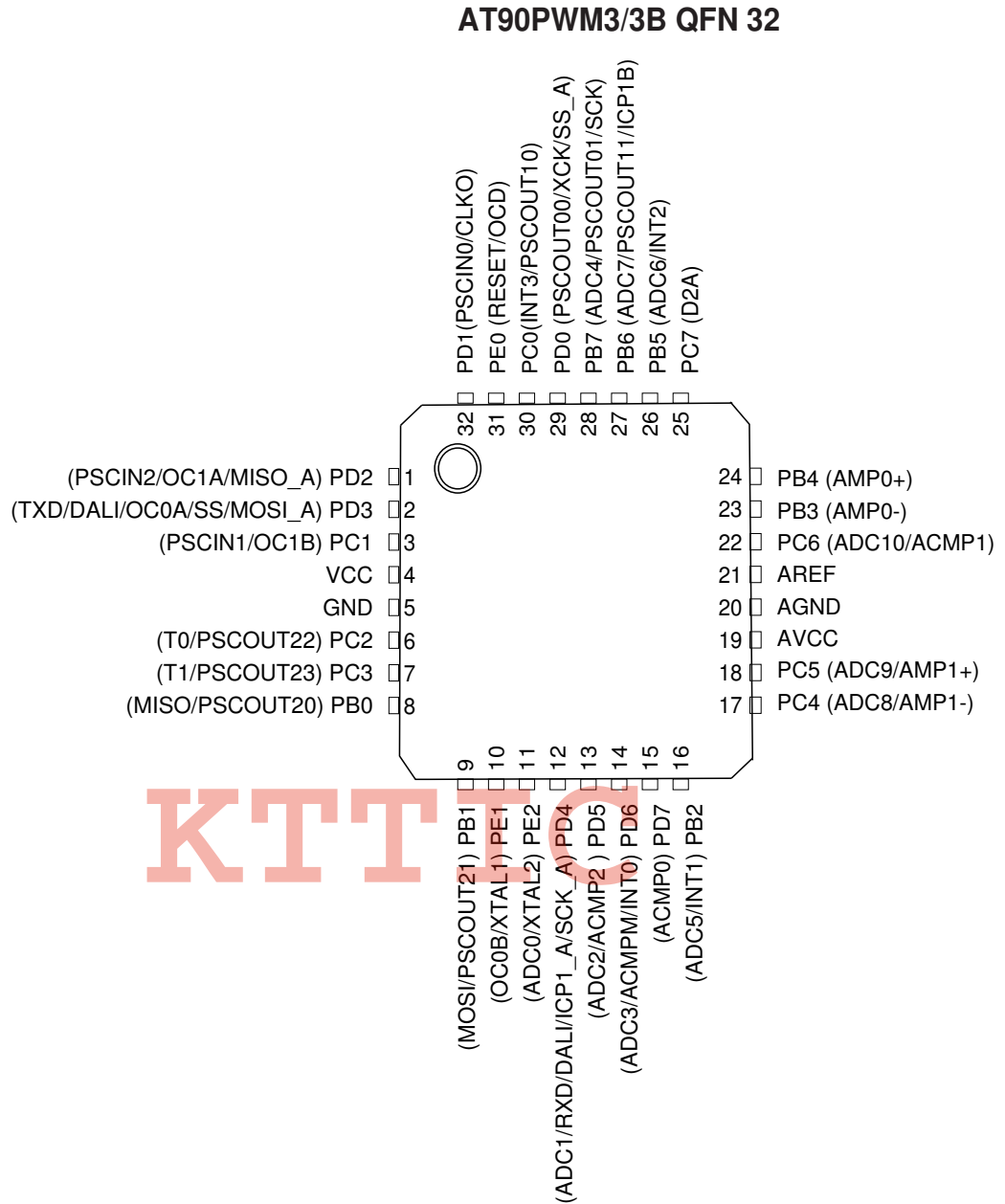

Figure 3-3. QFN32 (7*7 mm) Package.



3.1 Pin Descriptions

Table 3-1. Pin out description

| S024 Pin Number | S032 Pin Number | QFN32 Pin Number | Mnemonic | Type | Name, Function & Alternate Function |
|-----------------|-----------------|------------------|----------|-------|--|
| 7 | 9 | 5 | GND | Power | Ground: 0V reference |
| 18 | 24 | 20 | AGND | Power | Analog Ground: 0V reference for analog part |

Table 3-1. Pin out description (Continued)

| S024 Pin Number | SO32 Pin Number | QFN32 Pin Number | Mnemonic | Type | Name, Function & Alternate Function |
|-----------------|-----------------|------------------|----------|-------|--|
| 6 | 8 | 4 | VCC | power | Power Supply: |
| 17 | 23 | 19 | AVCC | Power | Analog Power Supply: This is the power supply voltage for analog part For a normal use this pin must be connected. |
| 19 | 25 | 21 | AREF | Power | Analog Reference : reference for analog converter . This is the reference voltage of the A/D converter. As output, can be used by external analog |
| 8 | 12 | 8 | PBO | I/O | MISO (SPI Master In Slave Out) PSCOUT20 output |
| 9 | 13 | 9 | PB1 | I/O | MOSI (SPI Master Out Slave In) PSCOUT21 output |
| 16 | 20 | 16 | PB2 | I/O | ADC5 (Analog Input Channel5) INT1 |
| 20 | 27 | 23 | PB3 | I/O | AMP0- (Analog Differential Amplifier 0 Input Channel) |
| 21 | 28 | 24 | PB4 | I/O | AMP0+ (Analog Differential Amplifier 0 Input Channel) |
| 22 | 30 | 26 | PB5 | I/O | ADC6 (Analog Input Channel 6) INT 2 |
| 23 | 31 | 27 | PB6 | I/O | ADC7 (Analog Input Channel 7) ICP1B (Timer 1 input capture alternate input) PSCOUT11 output (see note 1) |
| 24 | 32 | 28 | PB7 | I/O | PSCOUT01 output ADC4 (Analog Input Channel 4) SCK (SPI Clock) |
| NA | 2 | 30 | PC0 | I/O | PSCOUT10 output (see note 1) INT3 |
| | 7 | 3 | PC1 | I/O | PSCIN1 (PSC 1 Digital Input) OC1B (Timer 1 Output Compare B) |
| | 10 | 6 | PC2 | I/O | T0 (Timer 0 clock input) PSCOUT22 output |
| | 11 | 7 | PC3 | I/O | T1 (Timer 1 clock input) PSCOUT23 output |
| | 21 | 17 | PC4 | I/O | ADC8 (Analog Input Channel 8) AMP1- (Analog Differential Amplifier 1 Input Channel) |
| | 22 | 18 | PC5 | I/O | ADC9 (Analog Input Channel 9) AMP1+ (Analog Differential Amplifier 1 Input Channel) |
| | 26 | 22 | PC6 | I/O | ADC10 (Analog Input Channel 10) ACMP1 (Analog Comparator 1 Positive Input) |
| | 29 | 25 | PC7 | I/O | D2A : DAC output |

Table 3-1. Pin out description (Continued)

| S024 Pin Number | SO32 Pin Number | QFN32 Pin Number | Mnemonic | Type | Name, Function & Alternate Function |
|-----------------|-----------------|------------------|----------|----------|---|
| 1 | 1 | 29 | PD0 | I/O | PSCOUT0 output XCK (UART Transfer Clock) SS_A (Alternate SPI Slave Select) |
| 3 | 4 | 32 | PD1 | I/O | PSCIN0 (PSC 0 Digital Input) CLKO (System Clock Output) |
| 4 | 5 | 1 | PD2 | I/O | PSCIN2 (PSC 2 Digital Input) OC1A (Timer 1 Output Compare A) MISO_A (Programming & alternate SPI Master In Slave Out) |
| 5 | 6 | 2 | PD3 | I/O | TXD (Dali/UART Tx data) OC0A (Timer 0 Output Compare A) SS (SPI Slave Select) MOSI_A (Programming & alternate Master Out SPI Slave In) |
| 12 | 16 | 12 | PD4 | I/O | ADC1 (Analog Input Channel 1) RXD (Dali/UART Rx data) ICP1A (Timer 1 input capture) SCK_A (Programming & alternate SPI Clock) |
| 13 | 17 | 13 | PD5 | I/O | ADC2 (Analog Input Channel 2) ACMP2 (Analog Comparator 2 Positive Input) |
| 14 | 18 | 14 | PD6 | I/O | ADC3 (Analog Input Channel 3) ACMPM reference for analog comparators INT0 |
| 15 | 19 | 15 | PD7 | I/O | ACMP0 (Analog Comparator 0 Positive Input) |
| 2 | 3 | 31 | PE0 | I/O or I | RESET (Reset Input) OCD (On Chip Debug I/O) |
| 10 | 14 | 10 | PE1 | I/O | XTAL1: XTAL Input OC0B (Timer 0 Output Compare B) |
| 11 | 15 | 11 | PE2 | I/O | XTAL2: XTAL OuTput ADC0 (Analog Input Channel 0) |

1. PSCOUT10 & PSCOUT11 are not present on 24 pins package

4. Overview

The AT90PWM2/2B/3/3B is a low-power CMOS 8-bit microcontroller based on the AVR enhanced RISC architecture. By executing powerful instructions in a single clock cycle, the AT90PWM2/2B/3/3B achieves throughputs approaching 1 MIPS per MHz allowing the system designer to optimize power consumption versus processing speed.

4.1 Block Diagram

Figure 4-1. Block Diagram

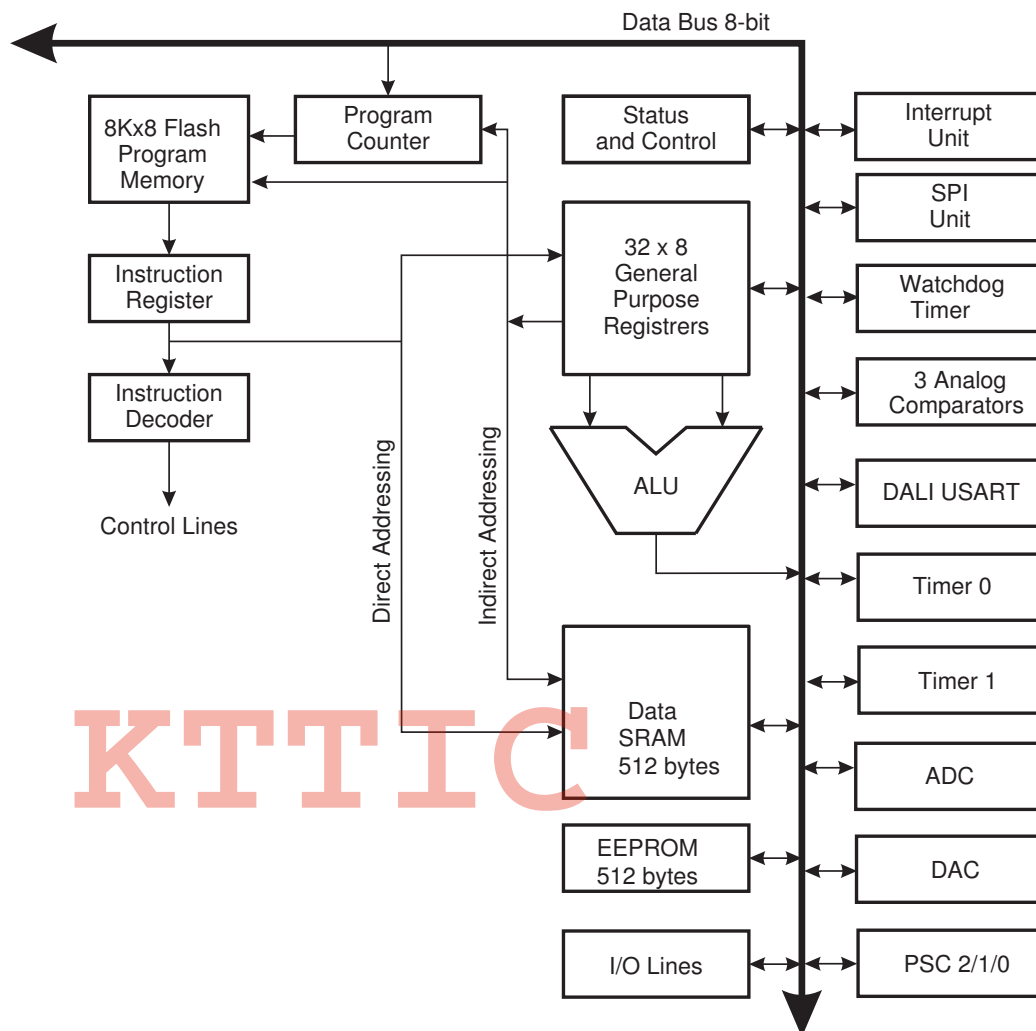

The AVR core combines a rich instruction set with 32 general purpose working registers. All the 32 registers are directly connected to the Arithmetic Logic Unit (ALU), allowing two independent registers to be accessed in one single instruction executed in one clock cycle. The resulting architecture is more code efficient while achieving throughputs up to ten times faster than conventional CISC microcontrollers.

The AT90PWM2/2B/3/3B provides the following features: 8K bytes of In-System Programmable Flash with Read-While-Write capabilities, 512 bytes EEPROM, 512 bytes SRAM, 53 general purpose I/O lines, 32 general purpose working registers, three Power Stage Controllers, two flexible Timer/Counters with compare modes and PWM, one USART with DALI mode, an 11-channel 10-bit ADC with two differential input stage with programmable gain, a 10-bit DAC, a programmable Watchdog Timer with Internal Oscillator, an SPI serial port, an On-chip Debug system and four software selectable power saving modes.

The Idle mode stops the CPU while allowing the SRAM, Timer/Counters, SPI ports and interrupt system to continue functioning. The Power-down mode saves the register contents but freezes the Oscillator, disabling all other chip functions until the next interrupt or Hardware Reset. The ADC Noise Reduction mode stops the CPU and all I/O modules except ADC, to minimize switching noise during ADC conversions. In Standby mode, the Crystal/Resonator Oscillator is running while the rest of the device is sleeping. This allows very fast start-up combined with low power consumption.

The device is manufactured using Atmel's high-density nonvolatile memory technology. The On-chip ISP Flash allows the program memory to be reprogrammed in-system through an SPI serial interface, by a conventional nonvolatile memory programmer, or by an On-chip Boot program running on the AVR core. The boot program can use any interface to download the application program in the application Flash memory. Software in the Boot Flash section will continue to run while the Application Flash section is updated, providing true Read-While-Write operation. By combining an 8-bit RISC CPU with In-System Self-Programmable Flash on a monolithic chip, the Atmel AT90PWM2/3 is a powerful microcontroller that provides a highly flexible and cost effective solution to many embedded control applications.

The AT90PWM2/3 AVR is supported with a full suite of program and system development tools including: C compilers, macro assemblers, program debugger/simulators, in-circuit emulators, and evaluation kits.

4.2 Pin Descriptions

4.2.1 VCC

Digital supply voltage.

4.2.2 GND

Ground.

4.2.3 Port B (PB7..PB0)

Port B is an 8-bit bi-directional I/O port with internal pull-up resistors (selected for each bit). The Port B output buffers have symmetrical drive characteristics with both high sink and source capability. As inputs, Port B pins that are externally pulled low will source current if the pull-up resistors are activated. The Port B pins are tri-stated when a reset condition becomes active, even if the clock is not running.

Port B also serves the functions of various special features of the AT90PWM2/2B/3/3B as listed on [page 69](#).

4.2.4 Port C (PC7..PC0)

Port C is an 8-bit bi-directional I/O port with internal pull-up resistors (selected for each bit). The Port C output buffers have symmetrical drive characteristics with both high sink and source capability. As inputs, Port C pins that are externally pulled low will source current if the pull-up resistors are activated. The Port C pins are tri-stated when a reset condition becomes active, even if the clock is not running.

Port C is not available on 24 pins package.

Port C also serves the functions of special features of the AT90PWM2/2B/3/3B as listed on [page 71](#).

4.2.5 Port D (PD7..PD0)

Port D is an 8-bit bi-directional I/O port with internal pull-up resistors (selected for each bit). The Port D output buffers have symmetrical drive characteristics with both high sink and source capability. As inputs, Port D pins that are externally pulled low will source current if the pull-up resistors are activated. The Port D pins are tri-stated when a reset condition becomes active, even if the clock is not running.

Port D also serves the functions of various special features of the AT90PWM2/2B/3/3B as listed on [page 74](#).

4.2.6 Port E (PE2..0) RESET/ XTAL1/ XTAL2

Port E is a 3-bit bi-directional I/O port with internal pull-up resistors (selected for each bit). The Port E output buffers have symmetrical drive characteristics with both high sink and source capability. As inputs, Port E pins that are externally pulled low will source current if the pull-up resistors are activated. The Port E pins are tri-stated when a reset condition becomes active, even if the clock is not running.

If the RSTDISBL Fuse is programmed, PE0 is used as an I/O pin. Note that the electrical characteristics of PE0 differ from those of the other pins of Port C.

If the RSTDISBL Fuse is unprogrammed, PE0 is used as a Reset input. A low level on this pin for longer than the minimum pulse length will generate a Reset, even if the clock is not running. The minimum pulse length is given in [Table 9-1 on page 47](#). Shorter pulses are not guaranteed to generate a Reset.

Depending on the clock selection fuse settings, PE1 can be used as input to the inverting Oscillator amplifier and input to the internal clock operating circuit.

Depending on the clock selection fuse settings, PE2 can be used as output from the inverting Oscillator amplifier.

The various special features of Port E are elaborated in [“Alternate Functions of Port E” on page 77](#) and [“Clock Systems and their Distribution” on page 29](#).

4.2.7 AVCC

AVCC is the supply voltage pin for the A/D Converter. It should be externally connected to V_{CC} , even if the ADC is not used. If the ADC is used, it should be connected to V_{CC} through a low-pass filter.

4.2.8 AREF

This is the analog reference pin for the A/D Converter.

4.3 About Code Examples

This documentation contains simple code examples that briefly show how to use various parts of the device. These code examples assume that the part specific header file is included before compilation. Be aware that not all C compiler vendors include bit definitions in the header files and interrupt handling in C is compiler dependent. Please confirm with the C compiler documentation for more details.

5. Register Summary

| Address | Name | Bit 7 | Bit 6 | Bit 5 | Bit 4 | Bit 3 | Bit 2 | Bit 1 | Bit 0 | Page |
|---------|----------|---------|---------|---------|---------|---------|---------|----------|---------|---------------------|
| (0xFF) | PICR2H | | | | | | | | | page 170 |
| (0xFE) | PICR2L | | | | | | | | | page 170 |
| (0xFD) | PFRC2B | PCAE2B | PISEL2B | PELEV2B | PFLTE2B | PRFM2B3 | PRFM2B2 | PRFM2B1 | PRFM2B0 | page 169 |
| (0xFC) | PFRC2A | PCAE2A | PISEL2A | PELEV2A | PFLTE2A | PRFM2A3 | PRFM2A2 | PRFM2A1 | PRFM2A0 | page 168 |
| (0xFB) | PCTL2 | PPRE21 | PPRE20 | PBFM2 | PAOC2B | PAOC2A | PARUN2 | PCCYC2 | PRUN2 | page 167 |
| (0xFA) | PCNF2 | PFIFTY2 | PALOCK2 | PLOCK2 | PMODE21 | PMODE20 | POP2 | PCLKSEL2 | POME2 | page 164 |
| (0xF9) | OCR2RBH | | | | | | | | | page 164 |
| (0xF8) | OCR2RBL | | | | | | | | | page 164 |
| (0xF7) | OCR2SBH | | | | | | | | | page 163 |
| (0xF6) | OCR2SBL | | | | | | | | | page 163 |
| (0xF5) | OCR2RAH | | | | | | | | | page 163 |
| (0xF4) | OCR2RAL | | | | | | | | | page 163 |
| (0xF3) | OCR2SAH | | | | | | | | | page 163 |
| (0xF2) | OCR2SAL | | | | | | | | | page 163 |
| (0xF1) | POM2 | POMV2B3 | POMV2B2 | POMV2B1 | POMV2B0 | POMV2A3 | POMV2A2 | POMV2A1 | POMV2A0 | page 171 |
| (0xF0) | PSOC2 | POS23 | POS22 | PSYNC21 | PSYNC20 | POEN2D | POEN2B | POEN2C | POEN2A | page 162 |
| (0xEF) | PICR1H | | | | | | | | | page 170 |
| (0xEE) | PICR1L | | | | | | | | | page 170 |
| (0xED) | PFRC1B | PCAE1B | PISEL1B | PELEV1B | PFLTE1B | PRFM1B3 | PRFM1B2 | PRFM1B1 | PRFM1B0 | page 169 |
| (0xEC) | PFRC1A | PCAE1A | PISEL1A | PELEV1A | PFLTE1A | PRFM1A3 | PRFM1A2 | PRFM1A1 | PRFM1A0 | page 168 |
| (0xEB) | PCTL1 | PPRE11 | PPRE10 | PBFM1 | PAOC1B | PAOC1A | PARUN1 | PCCYC1 | PRUN1 | page 166 |
| (0xEA) | PCNF1 | PFIFTY1 | PALOCK1 | PLOCK1 | PMODE11 | PMODE10 | POP1 | PCLKSEL1 | - | page 164 |
| (0xE9) | OCR1RBH | | | | | | | | | page 164 |
| (0xE8) | OCR1RBL | | | | | | | | | page 164 |
| (0xE7) | OCR1SBH | | | | | | | | | page 163 |
| (0xE6) | OCR1SBL | | | | | | | | | page 163 |
| (0xE5) | OCR1RAH | | | | | | | | | page 163 |
| (0xE4) | OCR1RAL | | | | | | | | | page 163 |
| (0xE3) | OCR1SAH | | | | | | | | | page 163 |
| (0xE2) | OCR1SAL | | | | | | | | | page 163 |
| (0xE1) | Reserved | - | - | - | - | - | - | - | - | |
| (0xE0) | PSOC1 | - | - | PSYNC11 | PSYNC10 | - | POEN1B | - | POEN1A | page 162 |
| (0xDF) | PICR0H | | | | | | | | | page 170 |
| (0xDE) | PICR0L | | | | | | | | | page 170 |
| (0xDD) | PFRC0B | PCAE0B | PISEL0B | PELEV0B | PFLTE0B | PRFM0B3 | PRFM0B2 | PRFM0B1 | PRFM0B0 | page 169 |
| (0xDC) | PFRC0A | PCAE0A | PISEL0A | PELEV0A | PFLTE0A | PRFM0A3 | PRFM0A2 | PRFM0A1 | PRFM0A0 | page 168 |
| (0xDB) | PCTL0 | PPRE01 | PPRE00 | PBFM0 | PAOC0B | PAOC0A | PARUN0 | PCCYC0 | PRUN0 | page 165 |
| (0xDA) | PCNF0 | PFIFTY0 | PALOCK0 | PLOCK0 | PMODE01 | PMODE00 | POP0 | PCLKSEL0 | - | page 164 |
| (0xD9) | OCR0RBH | | | | | | | | | page 164 |
| (0xD8) | OCR0RBL | | | | | | | | | page 164 |
| (0xD7) | OCR0SBH | | | | | | | | | page 163 |
| (0xD6) | OCR0SBL | | | | | | | | | page 163 |
| (0xD5) | OCR0RAH | | | | | | | | | page 163 |
| (0xD4) | OCR0RAL | | | | | | | | | page 163 |
| (0xD3) | OCR0SAH | | | | | | | | | page 163 |
| (0xD2) | OCR0SAL | | | | | | | | | page 163 |
| (0xD1) | Reserved | - | - | - | - | - | - | - | - | |
| (0xD0) | PSOC0 | - | - | PSYNC01 | PSYNC00 | - | POEN0B | - | POEN0A | page 162 |
| (0xCF) | Reserved | - | - | - | - | - | - | - | - | |
| (0xCE) | EUDR | EUDR7 | EUDR6 | EUDR5 | EUDR4 | EUDR3 | EUDR2 | EUDR1 | EUDR0 | page 221 |
| (0xCD) | MUBRRH | MUBRR15 | MUBRR14 | MUBRR13 | MUBRR12 | MUBRR11 | MUBRR10 | MUBRR9 | MUBRR8 | page 226 |
| (0xCC) | MUBRRL | MUBRR7 | MUBRR6 | MUBRR5 | MUBRR4 | MUBRR3 | MUBRR2 | MUBRR1 | MUBRR0 | page 226 |
| (0xCB) | Reserved | - | - | - | - | - | - | - | - | |
| (0xCA) | EUCSRC | - | - | - | - | FEM | F1617 | STP1 | STP0 | page 225 |
| (0xC9) | EUCSRB | - | - | - | EUSART | EUSBS | - | EMCH | BODR | page 224 |
| (0xC8) | EUCSRA | UTxS3 | UTxS2 | UTxS1 | UTxS0 | URxS3 | URxS2 | URxS1 | URxS0 | page 223 |
| (0xC7) | Reserved | - | - | - | - | - | - | - | - | |
| (0xC6) | UDR | UDR07 | UDR06 | UDR05 | UDR04 | UDR03 | UDR02 | UDR01 | UDR00 | page 221 & page 202 |
| (0xC5) | UBRRH | - | - | - | - | UBRR011 | UBRR010 | UBRR09 | UBRR08 | page 207 |
| (0xC4) | UBRRL | UBRR07 | UBRR06 | UBRR05 | UBRR04 | UBRR03 | UBRR02 | UBRR01 | UBRR00 | page 207 |
| (0xC3) | Reserved | - | - | - | - | - | - | - | - | |
| (0xC2) | UCSRC | - | UMSEL0 | UPM01 | UPM00 | USBS0 | UCSZ01 | UCSZ00 | UCPOL0 | page 205 |
| (0xC1) | UCSRB | RXCIE0 | TXCIE0 | UDRIE0 | RXEN0 | TXEN0 | UCSZ02 | RXB80 | TXB80 | page 204 |
| (0xC0) | UCSRA | RXC0 | TXC0 | UDRE0 | FE0 | DOR0 | UPE0 | U2X0 | MPCM0 | page 203 |
| (0xBF) | Reserved | - | - | - | - | - | - | - | - | |

| Address | Name | Bit 7 | Bit 6 | Bit 5 | Bit 4 | Bit 3 | Bit 2 | Bit 1 | Bit 0 | Page |
|---------|----------|-------------|-------------|----------|----------|--------------|---------------|--------------|--------------|--------------------------|
| (0xBE) | Reserved | - | - | - | - | - | - | - | - | |
| (0xBD) | Reserved | - | - | - | - | - | - | - | - | |
| (0xBC) | Reserved | - | - | - | - | - | - | - | - | |
| (0xBB) | Reserved | - | - | - | - | - | - | - | - | |
| (0xBA) | Reserved | - | - | - | - | - | - | - | - | |
| (0xB9) | Reserved | - | - | - | - | - | - | - | - | |
| (0xB8) | Reserved | - | - | - | - | - | - | - | - | |
| (0xB7) | Reserved | - | - | - | - | - | - | - | - | |
| (0xB6) | Reserved | - | - | - | - | - | - | - | - | |
| (0xB5) | Reserved | - | - | - | - | - | - | - | - | |
| (0xB4) | Reserved | - | - | - | - | - | - | - | - | |
| (0xB3) | Reserved | - | - | - | - | - | - | - | - | |
| (0xB2) | Reserved | - | - | - | - | - | - | - | - | |
| (0xB1) | Reserved | - | - | - | - | - | - | - | - | |
| (0xB0) | Reserved | - | - | - | - | - | - | - | - | |
| (0xAF) | AC2CON | AC2EN | AC2IE | AC2IS1 | AC2IS0 | AC2SADE- | AC2M2 | AC2M1 | AC2M0 | page 230 |
| (0xAE) | AC1CON | AC1EN | AC1IE | AC1IS1 | AC1IS0 | AC1ICE | AC1M2 | AC1M1 | AC1M0 | page 229 |
| (0xAD) | AC0CON | AC0EN | AC0IE | AC0IS1 | AC0IS0 | - | AC0M2 | AC0M1 | AC0M0 | page 228 |
| (0xAC) | DACH | - / DAC9 | - / DAC8 | - / DAC7 | - / DAC6 | - / DAC5 | - / DAC4 | DAC9 / DAC3 | DAC8 / DAC2 | page 262 |
| (0xAB) | DACL | DAC7 / DAC1 | DAC6 / DAC0 | DAC5 / - | DAC4 / - | DAC3 / - | DAC2 / - | DAC1 / - | DAC0 / | page 262 |
| (0xAA) | DACON | DAATE | DATS2 | DATS1 | DATS0 | - | DALA | DAOE | DAEN | page 261 |
| (0xA9) | Reserved | - | - | - | - | - | - | - | - | |
| (0xA8) | Reserved | - | - | - | - | - | - | - | - | |
| (0xA7) | Reserved | - | - | - | - | - | - | - | - | |
| (0xA6) | Reserved | - | - | - | - | - | - | - | - | |
| (0xA5) | PIM2 | - | - | PSEIE2 | PEVE2B | PEVE2A | - | - | PEOPE2 | page 172 |
| (0xA4) | PIFR2 | - | - | PSEIE2 | PEV2B | PEV2A | PRN21 | PRN20 | PEOP2 | page 172 |
| (0xA3) | PIM1 | - | - | PSEIE1 | PEVE1B | PEVE1A | - | - | PEOPE1 | page 171 |
| (0xA2) | PIFR1 | - | - | PSEIE1 | PEV1B | PEV1A | PRN11 | PRN10 | PEOP1 | page 172 |
| (0xA1) | PIM0 | - | - | PSEIE0 | PEVE0B | PEVE0A | - | - | PEOPE0 | page 171 |
| (0xA0) | PIFR0 | - | - | PSEIE0 | PEV0B | PEV0A | PRN01 | PRN00 | PEOP0 | page 172 |
| (0x9F) | Reserved | - | - | - | - | - | - | - | - | |
| (0x9E) | Reserved | - | - | - | - | - | - | - | - | |
| (0x9D) | Reserved | - | - | - | - | - | - | - | - | |
| (0x9C) | Reserved | - | - | - | - | - | - | - | - | |
| (0x9B) | Reserved | - | - | - | - | - | - | - | - | |
| (0x9A) | Reserved | - | - | - | - | - | - | - | - | |
| (0x99) | Reserved | - | - | - | - | - | - | - | - | |
| (0x98) | Reserved | - | - | - | - | - | - | - | - | |
| (0x97) | Reserved | - | - | - | - | - | - | - | - | |
| (0x96) | Reserved | - | - | - | - | - | - | - | - | |
| (0x95) | Reserved | - | - | - | - | - | - | - | - | |
| (0x94) | Reserved | - | - | - | - | - | - | - | - | |
| (0x93) | Reserved | - | - | - | - | - | - | - | - | |
| (0x92) | Reserved | - | - | - | - | - | - | - | - | |
| (0x91) | Reserved | - | - | - | - | - | - | - | - | |
| (0x90) | Reserved | - | - | - | - | - | - | - | - | |
| (0x8F) | Reserved | - | - | - | - | - | - | - | - | |
| (0x8E) | Reserved | - | - | - | - | - | - | - | - | |
| (0x8D) | Reserved | - | - | - | - | - | - | - | - | |
| (0x8C) | Reserved | - | - | - | - | - | - | - | - | |
| (0x8B) | OCR1BH | OCR1B15 | OCR1B14 | OCR1B13 | OCR1B12 | OCR1B11 | OCR1B10 | OCR1B9 | OCR1B8 | page 127 |
| (0x8A) | OCR1BL | OCR1B7 | OCR1B6 | OCR1B5 | OCR1B4 | OCR1B3 | OCR1B2 | OCR1B1 | OCR1B0 | page 127 |
| (0x89) | OCR1AH | OCR1A15 | OCR1A14 | OCR1A13 | OCR1A12 | OCR1A11 | OCR1A10 | OCR1A9 | OCR1A8 | page 127 |
| (0x88) | OCR1AL | OCR1A7 | OCR1A6 | OCR1A5 | OCR1A4 | OCR1A3 | OCR1A2 | OCR1A1 | OCR1A0 | page 127 |
| (0x87) | ICR1H | ICR115 | ICR114 | ICR113 | ICR112 | ICR111 | ICR110 | ICR19 | ICR18 | page 128 |
| (0x86) | ICR1L | ICR17 | ICR16 | ICR15 | ICR14 | ICR13 | ICR12 | ICR11 | ICR10 | page 128 |
| (0x85) | TCNT1H | TCNT115 | TCNT114 | TCNT113 | TCNT112 | TCNT111 | TCNT110 | TCNT19 | TCNT18 | page 127 |
| (0x84) | TCNT1L | TCNT17 | TCNT16 | TCNT15 | TCNT14 | TCNT13 | TCNT12 | TCNT11 | TCNT10 | page 127 |
| (0x83) | Reserved | - | - | - | - | - | - | - | - | |
| (0x82) | TCCR1C | FOC1A | FOC1B | - | - | - | - | - | - | page 127 |
| (0x81) | TCCR1B | ICNC1 | ICES1 | - | WGM13 | WGM12 | CS12 | CS11 | CS10 | page 126 |
| (0x80) | TCCR1A | COM1A1 | COM1A0 | COM1B1 | COM1B0 | - | - | WGM11 | WGM10 | page 123 |
| (0x7F) | DIDR1 | - | - | ACMP0D | AMP0PD | AMP0ND | ADC10D/ACMP1D | ADC9D/AMP1PD | ADC8D/AMP1ND | page 252 |
| (0x7E) | DIDR0 | ADC7D | ADC6D | ADC5D | ADC4D | ADC3D/ACMPMD | ADC2D/ACMP2D | ADC1D | ADC0D | page 251 |
| (0x7D) | Reserved | - | - | - | - | - | - | - | - | |

| Address | Name | Bit 7 | Bit 6 | Bit 5 | Bit 4 | Bit 3 | Bit 2 | Bit 1 | Bit 0 | Page |
|-------------|----------|------------------------------------|-------------|----------|----------|----------|----------|-------------|-------------|---------------------------------------|
| (0x7C) | ADMUX | REFS1 | REFS0 | ADLAR | – | MUX3 | MUX2 | MUX1 | MUX0 | page 247 |
| (0x7B) | ADCSRB | ADHSM | – | – | ADASCR | ADTS3 | ADTS2 | ADTS1 | ADTS0 | page 249 |
| (0x7A) | ADCSRA | ADEN | ADSC | ADATE | ADIF | ADIE | ADPS2 | ADPS1 | ADPS0 | page 248 |
| (0x79) | ADCH | - / ADC9 | - / ADC8 | - / ADC7 | - / ADC6 | - / ADC5 | - / ADC4 | ADC9 / ADC3 | ADC8 / ADC2 | page 251 |
| (0x78) | ADCL | ADC7 / ADC1 | ADC6 / ADC0 | ADC5 / - | ADC4 / - | ADC3 / - | ADC2 / - | ADC1 / - | ADC0 / - | page 251 |
| (0x77) | AMP1CSR | AMP1EN | - | AMP1G1 | AMP1G0 | - | AMP1TS2 | AMP1TS1 | AMP1TS0 | page 257 |
| (0x76) | AMPOCSR | AMPOEN | - | AMPOG1 | AMPOG0 | - | AMPOTS2 | AMPOTS1 | AMPOTS0 | page 256 |
| (0x75) | Reserved | – | – | – | – | – | – | – | – | |
| (0x74) | Reserved | – | – | – | – | – | – | – | – | |
| (0x73) | Reserved | – | – | – | – | – | – | – | – | |
| (0x72) | Reserved | – | – | – | – | – | – | – | – | |
| (0x71) | Reserved | – | – | – | – | – | – | – | – | |
| (0x70) | Reserved | – | – | – | – | – | – | – | – | |
| (0x6F) | TIMSK1 | – | – | ICIE1 | – | – | OCIE1B | OCIE1A | TOIE1 | page 128 |
| (0x6E) | TIMSK0 | – | – | – | – | – | OCIE0B | OCIE0A | TOIE0 | page 101 |
| (0x6D) | Reserved | – | – | – | – | – | – | – | – | |
| (0x6C) | Reserved | – | – | – | – | – | – | – | – | |
| (0x6B) | Reserved | – | – | – | – | – | – | – | – | |
| (0x6A) | Reserved | – | – | – | – | – | – | – | – | |
| (0x69) | EICRA | ISC31 | ISC30 | ISC21 | ISC20 | ISC11 | ISC10 | ISC01 | ISC00 | page 81 |
| (0x68) | Reserved | – | – | – | – | – | – | – | – | |
| (0x67) | Reserved | – | – | – | – | – | – | – | – | |
| (0x66) | OSCCAL | – | CAL6 | CAL5 | CAL4 | CAL3 | CAL2 | CAL1 | CAL0 | page 34 |
| (0x65) | Reserved | – | – | – | – | – | – | – | – | |
| (0x64) | PRR | PRPSC2 | PRPSC1 | PRPSC0 | PRTIM1 | PRTIM0 | PRSPI | PRUSART | PRADC | page 43 |
| (0x63) | Reserved | – | – | – | – | – | – | – | – | |
| (0x62) | Reserved | – | – | – | – | – | – | – | – | |
| (0x61) | CLKPR | CLKPCE | – | – | – | CLKPS3 | CLKPS2 | CLKPS1 | CLKPS0 | page 39 |
| (0x60) | WDTCR | WDIF | WDIE | WDP3 | WDCE | WDE | WDP2 | WDP1 | WDP0 | page 54 |
| 0x3F (0x5F) | SREG | I | T | H | S | V | N | Z | C | page 13 |
| 0x3E (0x5E) | SPH | SP15 | SP14 | SP13 | SP12 | SP11 | SP10 | SP9 | SP8 | page 15 |
| 0x3D (0x5D) | SPL | SP7 | SP6 | SP5 | SP4 | SP3 | SP2 | SP1 | SP0 | page 15 |
| 0x3C (0x5C) | Reserved | – | – | – | – | – | – | – | – | |
| 0x3B (0x5B) | Reserved | – | – | – | – | – | – | – | – | |
| 0x3A (0x5A) | Reserved | – | – | – | – | – | – | – | – | |
| 0x39 (0x59) | Reserved | – | – | – | – | – | – | – | – | |
| 0x38 (0x58) | Reserved | – | – | – | – | – | – | – | – | |
| 0x37 (0x57) | SPMCSR | SPMIE | RWWSB | – | RWWSRE | BLBSET | PGWRT | PGERS | SPMEN | page 271 |
| 0x36 (0x56) | Reserved | – | – | – | – | – | – | – | – | |
| 0x35 (0x55) | MCUCR | SPIPS | – | – | PUD | – | – | IVSEL | IVCE | page 60 & page 68 |
| 0x34 (0x54) | MCUSR | – | – | – | – | WDRF | BORF | EXTRF | PORF | page 50 |
| 0x33 (0x53) | SMCR | – | – | – | – | SM2 | SM1 | SM0 | SE | page 41 |
| 0x32 (0x52) | MSMCR | Monitor Stop Mode Control Register | | | | | | | | reserved |
| 0x31 (0x51) | MONDR | Monitor Data Register | | | | | | | | reserved |
| 0x30 (0x50) | ACSR | ACCKDIV | AC2IF | AC1IF | AC0IF | – | AC2O | AC1O | AC0O | page 231 |
| 0x2F (0x4F) | Reserved | – | – | – | – | – | – | – | – | |
| 0x2E (0x4E) | SPDR | SPD7 | SPD6 | SPD5 | SPD4 | SPD3 | SPD2 | SPD1 | SPD0 | page 181 |
| 0x2D (0x4D) | SPSR | SPIF | WCOL | – | – | – | – | – | SPI2X | page 181 |
| 0x2C (0x4C) | SPCR | SPIE | SPE | DORD | MSTR | CPOL | CPHA | SPR1 | SPR0 | page 179 |
| 0x2B (0x4B) | Reserved | – | – | – | – | – | – | – | – | |
| 0x2A (0x4A) | Reserved | – | – | – | – | – | – | – | – | |
| 0x29 (0x49) | PLLCSR | – | – | – | – | – | PLLF | PLLE | PLOCK | page 37 |
| 0x28 (0x48) | OCR0B | OCR0B7 | OCR0B6 | OCR0B5 | OCR0B4 | OCR0B3 | OCR0B2 | OCR0B1 | OCR0B0 | page 101 |
| 0x27 (0x47) | OCR0A | OCR0A7 | OCR0A6 | OCR0A5 | OCR0A4 | OCR0A3 | OCR0A2 | OCR0A1 | OCR0A0 | page 100 |
| 0x26 (0x46) | TCNT0 | TCNT07 | TCNT06 | TCNT05 | TCNT04 | TCNT03 | TCNT02 | TCNT01 | TCNT00 | page 100 |
| 0x25 (0x45) | TCCR0B | FOCOA | FOC0B | – | – | WGM02 | CS02 | CS01 | CS00 | page 99 |
| 0x24 (0x44) | TCCR0A | COM0A1 | COM0A0 | COM0B1 | COM0B0 | – | – | WGM01 | WGM00 | page 96 |
| 0x23 (0x43) | GTCCR | TSM | ICPSEL1 | – | – | – | – | – | PSRSYNC | page 84 |
| 0x22 (0x42) | EEARH | – | – | – | – | EEAR11 | EEAR10 | EEAR9 | EEAR8 | page 21 |
| 0x21 (0x41) | EEARL | EEAR7 | EEAR6 | EEAR5 | EEAR4 | EEAR3 | EEAR2 | EEAR1 | EEAR0 | page 21 |
| 0x20 (0x40) | EEDR | EEDR7 | EEDR6 | EEDR5 | EEDR4 | EEDR3 | EEDR2 | EEDR1 | EEDR0 | page 22 |
| 0x1F (0x3F) | EEDR | – | – | – | – | EERIE | EEMWE | EWE | EERE | page 22 |
| 0x1E (0x3E) | GPOR0 | GPOR07 | GPOR06 | GPOR05 | GPOR04 | GPOR03 | GPOR02 | GPOR01 | GPOR00 | page 27 |
| 0x1D (0x3D) | EIMSK | – | – | – | – | INT3 | INT2 | INT1 | INT0 | page 82 |
| 0x1C (0x3C) | EIFR | – | – | – | – | INTF3 | INTF2 | INTF1 | INTF0 | page 82 |
| 0x1B (0x3B) | GPOR3 | GPOR37 | GPOR36 | GPOR35 | GPOR34 | GPOR33 | GPOR32 | GPOR31 | GPOR30 | page 28 |

| Address | Name | Bit 7 | Bit 6 | Bit 5 | Bit 4 | Bit 3 | Bit 2 | Bit 1 | Bit 0 | Page |
|-------------|-----------------|---------|---------|---------|---------|---------|---------|---------|---------|--------------------------|
| 0x1A (0x3A) | GPIOR2 | GPIOR27 | GPIOR26 | GPIOR25 | GPIOR24 | GPIOR23 | GPIOR22 | GPIOR21 | GPIOR20 | page 27 |
| 0x19 (0x39) | GPIOR1 | GPIOR17 | GPIOR16 | GPIOR15 | GPIOR14 | GPIOR13 | GPIOR12 | GPIOR11 | GPIOR10 | page 27 |
| 0x18 (0x38) | Reserved | – | – | – | – | – | – | – | – | |
| 0x17 (0x37) | Reserved | – | – | – | – | – | – | – | – | |
| 0x16 (0x36) | TIFR1 | – | – | ICF1 | – | – | OCF1B | OCF1A | TOV1 | page 129 |
| 0x15 (0x35) | TIFR0 | – | – | – | – | – | OCF0B | OCF0A | TOV0 | page 101 |
| 0x14 (0x34) | Reserved | – | – | – | – | – | – | – | – | |
| 0x13 (0x33) | Reserved | – | – | – | – | – | – | – | – | |
| 0x12 (0x32) | Reserved | – | – | – | – | – | – | – | – | |
| 0x11 (0x31) | Reserved | – | – | – | – | – | – | – | – | |
| 0x10 (0x30) | Reserved | – | – | – | – | – | – | – | – | |
| 0x0F (0x2F) | Reserved | – | – | – | – | – | – | – | – | |
| 0x0E (0x2E) | PORTE | – | – | – | – | – | PORTE2 | PORTE1 | PORTE0 | page 79 |
| 0x0D (0x2D) | DDRE | – | – | – | – | – | DDE2 | DDE1 | DDE0 | page 80 |
| 0x0C (0x2C) | PINE | – | – | – | – | – | PINE2 | PINE1 | PINE0 | page 80 |
| 0x0B (0x2B) | PORTD | PORTD7 | PORTD6 | PORTD5 | PORTD4 | PORTD3 | PORTD2 | PORTD1 | PORTD0 | page 79 |
| 0x0A (0x2A) | DDRD | DDD7 | DDD6 | DDD5 | DDD4 | DDD3 | DDD2 | DDD1 | DDD0 | page 79 |
| 0x09 (0x29) | PIND | PIND7 | PIND6 | PIND5 | PIND4 | PIND3 | PIND2 | PIND1 | PIND0 | page 79 |
| 0x08 (0x28) | PORTC | PORTC7 | PORTC6 | PORTC5 | PORTC4 | PORTC3 | PORTC2 | PORTC1 | PORTC0 | page 79 |
| 0x07 (0x27) | DDRC | DDC7 | DDC6 | DDC5 | DDC4 | DDC3 | DDC2 | DDC1 | DDC0 | page 79 |
| 0x06 (0x26) | PINC | PINC7 | PINC6 | PINC5 | PINC4 | PINC3 | PINC2 | PINC1 | PINC0 | page 79 |
| 0x05 (0x25) | PORTB | PORTB7 | PORTB6 | PORTB5 | PORTB4 | PORTB3 | PORTB2 | PORTB1 | PORTB0 | page 78 |
| 0x04 (0x24) | DDRB | DDB7 | DDB6 | DDB5 | DDB4 | DDB3 | DDB2 | DDB1 | DDB0 | page 78 |
| 0x03 (0x23) | PINB | PINB7 | PINB6 | PINB5 | PINB4 | PINB3 | PINB2 | PINB1 | PINB0 | page 79 |
| 0x02 (0x22) | Reserved | – | – | – | – | – | – | – | – | |
| 0x01 (0x21) | Reserved | – | – | – | – | – | – | – | – | |
| 0x00 (0x20) | Reserved | – | – | – | – | – | – | – | – | |

- Note:
- For compatibility with future devices, reserved bits should be written to zero if accessed. Reserved I/O memory addresses should never be written.
 - I/O Registers within the address range 0x00 - 0x1F are directly bit-accessible using the SBI and CBI instructions. In these registers, the value of single bits can be checked by using the SBIS and SBIC instructions.
 - Some of the status flags are cleared by writing a logical one to them. Note that, unlike most other AVRs, the CBI and SBI instructions will only operate on the specified bit, and can therefore be used on registers containing such status flags. The CBI and SBI instructions work with registers 0x00 to 0x1F only.
 - When using the I/O specific commands IN and OUT, the I/O addresses 0x00 - 0x3F must be used. When addressing I/O Registers as data space using LD and ST instructions, 0x20 must be added to these addresses. The AT90PWM2/2B/3/3B is a complex microcontroller with more peripheral units than can be supported within the 64 location reserved in Opcode for the IN and OUT instructions. For the Extended I/O space from 0x60 - 0xFF in SRAM, only the ST/STS/STD and LD/LDS/LDD instructions can be used.

6. Instruction Set Summary

| Mnemonics | Operands | Description | Operation | Flags | #Clocks |
|--|----------|--|--|------------|---------|
| ARITHMETIC AND LOGIC INSTRUCTIONS | | | | | |
| ADD | Rd, Rr | Add two Registers | $Rd \leftarrow Rd + Rr$ | Z,C,N,V,H | 1 |
| ADC | Rd, Rr | Add with Carry two Registers | $Rd \leftarrow Rd + Rr + C$ | Z,C,N,V,H | 1 |
| ADIW | Rdl,K | Add Immediate to Word | $Rdh:Rdl \leftarrow Rdh:Rdl + K$ | Z,C,N,V,S | 2 |
| SUB | Rd, Rr | Subtract two Registers | $Rd \leftarrow Rd - Rr$ | Z,C,N,V,H | 1 |
| SUBI | Rd, K | Subtract Constant from Register | $Rd \leftarrow Rd - K$ | Z,C,N,V,H | 1 |
| SBC | Rd, Rr | Subtract with Carry two Registers | $Rd \leftarrow Rd - Rr - C$ | Z,C,N,V,H | 1 |
| SBCI | Rd, K | Subtract with Carry Constant from Reg. | $Rd \leftarrow Rd - K - C$ | Z,C,N,V,H | 1 |
| SBIW | Rdl,K | Subtract Immediate from Word | $Rdh:Rdl \leftarrow Rdh:Rdl - K$ | Z,C,N,V,S | 2 |
| AND | Rd, Rr | Logical AND Registers | $Rd \leftarrow Rd \cdot Rr$ | Z,N,V | 1 |
| ANDI | Rd, K | Logical AND Register and Constant | $Rd \leftarrow Rd \cdot K$ | Z,N,V | 1 |
| OR | Rd, Rr | Logical OR Registers | $Rd \leftarrow Rd \vee Rr$ | Z,N,V | 1 |
| ORI | Rd, K | Logical OR Register and Constant | $Rd \leftarrow Rd \vee K$ | Z,N,V | 1 |
| EOR | Rd, Rr | Exclusive OR Registers | $Rd \leftarrow Rd \oplus Rr$ | Z,N,V | 1 |
| COM | Rd | One's Complement | $Rd \leftarrow 0xFF - Rd$ | Z,C,N,V | 1 |
| NEG | Rd | Two's Complement | $Rd \leftarrow 0x00 - Rd$ | Z,C,N,V,H | 1 |
| SBR | Rd,K | Set Bit(s) in Register | $Rd \leftarrow Rd \vee K$ | Z,N,V | 1 |
| CBR | Rd,K | Clear Bit(s) in Register | $Rd \leftarrow Rd \cdot (0xFF - K)$ | Z,N,V | 1 |
| INC | Rd | Increment | $Rd \leftarrow Rd + 1$ | Z,N,V | 1 |
| DEC | Rd | Decrement | $Rd \leftarrow Rd - 1$ | Z,N,V | 1 |
| TST | Rd | Test for Zero or Minus | $Rd \leftarrow Rd \cdot Rd$ | Z,N,V | 1 |
| CLR | Rd | Clear Register | $Rd \leftarrow Rd \oplus Rd$ | Z,N,V | 1 |
| SER | Rd | Set Register | $Rd \leftarrow 0xFF$ | None | 1 |
| MUL | Rd, Rr | Multiply Unsigned | $R1:R0 \leftarrow Rd \times Rr$ | Z,C | 2 |
| MULS | Rd, Rr | Multiply Signed | $R1:R0 \leftarrow Rd \times Rr$ | Z,C | 2 |
| MULSU | Rd, Rr | Multiply Signed with Unsigned | $R1:R0 \leftarrow Rd \times Rr$ | Z,C | 2 |
| FMUL | Rd, Rr | Fractional Multiply Unsigned | $R1:R0 \leftarrow (Rd \times Rr) \ll 1$ | Z,C | 2 |
| FMULS | Rd, Rr | Fractional Multiply Signed | $R1:R0 \leftarrow (Rd \times Rr) \ll 1$ | Z,C | 2 |
| FMULSU | Rd, Rr | Fractional Multiply Signed with Unsigned | $R1:R0 \leftarrow (Rd \times Rr) \ll 1$ | Z,C | 2 |
| BRANCH INSTRUCTIONS | | | | | |
| RJMP | k | Relative Jump | $PC \leftarrow PC + k + 1$ | None | 2 |
| IJMP | | Indirect Jump to (Z) | $PC \leftarrow Z$ | None | 2 |
| RCALL | k | Relative Subroutine Call | $PC \leftarrow PC + k + 1$ | None | 3 |
| ICALL | | Indirect Call to (Z) | $PC \leftarrow Z$ | None | 3 |
| RET | | Subroutine Return | $PC \leftarrow STACK$ | None | 4 |
| RETI | | Interrupt Return | $PC \leftarrow STACK$ | I | 4 |
| CPSE | Rd,Rr | Compare, Skip if Equal | if (Rd = Rr) $PC \leftarrow PC + 2$ or 3 | None | 1/2/3 |
| CP | Rd,Rr | Compare | $Rd - Rr$ | Z, N,V,C,H | 1 |
| CPC | Rd,Rr | Compare with Carry | $Rd - Rr - C$ | Z, N,V,C,H | 1 |
| CPI | Rd,K | Compare Register with Immediate | $Rd - K$ | Z, N,V,C,H | 1 |
| SBRC | Rr, b | Skip if Bit in Register Cleared | if (Rr(b)=0) $PC \leftarrow PC + 2$ or 3 | None | 1/2/3 |
| SBRS | Rr, b | Skip if Bit in Register is Set | if (Rr(b)=1) $PC \leftarrow PC + 2$ or 3 | None | 1/2/3 |
| SBIC | P, b | Skip if Bit in I/O Register Cleared | if (P(b)=0) $PC \leftarrow PC + 2$ or 3 | None | 1/2/3 |
| SBIS | P, b | Skip if Bit in I/O Register is Set | if (P(b)=1) $PC \leftarrow PC + 2$ or 3 | None | 1/2/3 |
| BRBS | s, k | Branch if Status Flag Set | if (SREG(s) = 1) then $PC \leftarrow PC + k + 1$ | None | 1/2 |
| BRBC | s, k | Branch if Status Flag Cleared | if (SREG(s) = 0) then $PC \leftarrow PC + k + 1$ | None | 1/2 |
| BREQ | k | Branch if Equal | if (Z = 1) then $PC \leftarrow PC + k + 1$ | None | 1/2 |
| BRNE | k | Branch if Not Equal | if (Z = 0) then $PC \leftarrow PC + k + 1$ | None | 1/2 |
| BRCS | k | Branch if Carry Set | if (C = 1) then $PC \leftarrow PC + k + 1$ | None | 1/2 |
| BRCC | k | Branch if Carry Cleared | if (C = 0) then $PC \leftarrow PC + k + 1$ | None | 1/2 |
| BRSH | k | Branch if Same or Higher | if (C = 0) then $PC \leftarrow PC + k + 1$ | None | 1/2 |
| BRLO | k | Branch if Lower | if (C = 1) then $PC \leftarrow PC + k + 1$ | None | 1/2 |
| BRMI | k | Branch if Minus | if (N = 1) then $PC \leftarrow PC + k + 1$ | None | 1/2 |
| BRPL | k | Branch if Plus | if (N = 0) then $PC \leftarrow PC + k + 1$ | None | 1/2 |
| BRGE | k | Branch if Greater or Equal, Signed | if (N ⊕ V = 0) then $PC \leftarrow PC + k + 1$ | None | 1/2 |
| BRLT | k | Branch if Less Than Zero, Signed | if (N ⊕ V = 1) then $PC \leftarrow PC + k + 1$ | None | 1/2 |
| BRHS | k | Branch if Half Carry Flag Set | if (H = 1) then $PC \leftarrow PC + k + 1$ | None | 1/2 |
| BRHC | k | Branch if Half Carry Flag Cleared | if (H = 0) then $PC \leftarrow PC + k + 1$ | None | 1/2 |
| BRTS | k | Branch if T Flag Set | if (T = 1) then $PC \leftarrow PC + k + 1$ | None | 1/2 |
| BRTC | k | Branch if T Flag Cleared | if (T = 0) then $PC \leftarrow PC + k + 1$ | None | 1/2 |
| BRVS | k | Branch if Overflow Flag is Set | if (V = 1) then $PC \leftarrow PC + k + 1$ | None | 1/2 |
| BRVC | k | Branch if Overflow Flag is Cleared | if (V = 0) then $PC \leftarrow PC + k + 1$ | None | 1/2 |
| BRIE | k | Branch if Interrupt Enabled | if (I = 1) then $PC \leftarrow PC + k + 1$ | None | 1/2 |
| BRID | k | Branch if Interrupt Disabled | if (I = 0) then $PC \leftarrow PC + k + 1$ | None | 1/2 |

| Mnemonics | Operands | Description | Operation | Flags | #Clocks |
|--------------------------------------|----------|----------------------------------|--|---------|---------|
| BIT AND BIT-TEST INSTRUCTIONS | | | | | |
| SBI | P,b | Set Bit in I/O Register | $I/O(P,b) \leftarrow 1$ | None | 2 |
| CBI | P,b | Clear Bit in I/O Register | $I/O(P,b) \leftarrow 0$ | None | 2 |
| LSL | Rd | Logical Shift Left | $Rd(n+1) \leftarrow Rd(n), Rd(0) \leftarrow 0$ | Z,C,N,V | 1 |
| LSR | Rd | Logical Shift Right | $Rd(n) \leftarrow Rd(n+1), Rd(7) \leftarrow 0$ | Z,C,N,V | 1 |
| ROL | Rd | Rotate Left Through Carry | $Rd(0) \leftarrow C, Rd(n+1) \leftarrow Rd(n), C \leftarrow Rd(7)$ | Z,C,N,V | 1 |
| ROR | Rd | Rotate Right Through Carry | $Rd(7) \leftarrow C, Rd(n) \leftarrow Rd(n+1), C \leftarrow Rd(0)$ | Z,C,N,V | 1 |
| ASR | Rd | Arithmetic Shift Right | $Rd(n) \leftarrow Rd(n+1), n=0..6$ | Z,C,N,V | 1 |
| SWAP | Rd | Swap Nibbles | $Rd(3..0) \leftarrow Rd(7..4), Rd(7..4) \leftarrow Rd(3..0)$ | None | 1 |
| BSET | s | Flag Set | $SREG(s) \leftarrow 1$ | SREG(s) | 1 |
| BCLR | s | Flag Clear | $SREG(s) \leftarrow 0$ | SREG(s) | 1 |
| BST | Rr, b | Bit Store from Register to T | $T \leftarrow Rr(b)$ | T | 1 |
| BLD | Rd, b | Bit load from T to Register | $Rd(b) \leftarrow T$ | None | 1 |
| SEC | | Set Carry | $C \leftarrow 1$ | C | 1 |
| CLC | | Clear Carry | $C \leftarrow 0$ | C | 1 |
| SEN | | Set Negative Flag | $N \leftarrow 1$ | N | 1 |
| CLN | | Clear Negative Flag | $N \leftarrow 0$ | N | 1 |
| SEZ | | Set Zero Flag | $Z \leftarrow 1$ | Z | 1 |
| CLZ | | Clear Zero Flag | $Z \leftarrow 0$ | Z | 1 |
| SEI | | Global Interrupt Enable | $I \leftarrow 1$ | I | 1 |
| CLI | | Global Interrupt Disable | $I \leftarrow 0$ | I | 1 |
| SES | | Set Signed Test Flag | $S \leftarrow 1$ | S | 1 |
| CLS | | Clear Signed Test Flag | $S \leftarrow 0$ | S | 1 |
| SEV | | Set Twos Complement Overflow | $V \leftarrow 1$ | V | 1 |
| CLV | | Clear Twos Complement Overflow | $V \leftarrow 0$ | V | 1 |
| SET | | Set T in SREG | $T \leftarrow 1$ | T | 1 |
| CLT | | Clear T in SREG | $T \leftarrow 0$ | T | 1 |
| SEH | | Set Half Carry Flag in SREG | $H \leftarrow 1$ | H | 1 |
| CLH | | Clear Half Carry Flag in SREG | $H \leftarrow 0$ | H | 1 |
| DATA TRANSFER INSTRUCTIONS | | | | | |
| MOV | Rd, Rr | Move Between Registers | $Rd \leftarrow Rr$ | None | 1 |
| MOVW | Rd, Rr | Copy Register Word | $Rd+1:Rd \leftarrow Rr+1:Rr$ | None | 1 |
| LDI | Rd, K | Load Immediate | $Rd \leftarrow K$ | None | 1 |
| LD | Rd, X | Load Indirect | $Rd \leftarrow (X)$ | None | 2 |
| LD | Rd, X+ | Load Indirect and Post-Inc. | $Rd \leftarrow (X), X \leftarrow X + 1$ | None | 2 |
| LD | Rd, -X | Load Indirect and Pre-Dec. | $X \leftarrow X - 1, Rd \leftarrow (X)$ | None | 2 |
| LD | Rd, Y | Load Indirect | $Rd \leftarrow (Y)$ | None | 2 |
| LD | Rd, Y+ | Load Indirect and Post-Inc. | $Rd \leftarrow (Y), Y \leftarrow Y + 1$ | None | 2 |
| LD | Rd, -Y | Load Indirect and Pre-Dec. | $Y \leftarrow Y - 1, Rd \leftarrow (Y)$ | None | 2 |
| LDD | Rd, Y+q | Load Indirect with Displacement | $Rd \leftarrow (Y + q)$ | None | 2 |
| LD | Rd, Z | Load Indirect | $Rd \leftarrow (Z)$ | None | 2 |
| LD | Rd, Z+ | Load Indirect and Post-Inc. | $Rd \leftarrow (Z), Z \leftarrow Z + 1$ | None | 2 |
| LD | Rd, -Z | Load Indirect and Pre-Dec. | $Z \leftarrow Z - 1, Rd \leftarrow (Z)$ | None | 2 |
| LDD | Rd, Z+q | Load Indirect with Displacement | $Rd \leftarrow (Z + q)$ | None | 2 |
| LDS | Rd, k | Load Direct from SRAM | $Rd \leftarrow (k)$ | None | 2 |
| ST | X, Rr | Store Indirect | $(X) \leftarrow Rr$ | None | 2 |
| ST | X+, Rr | Store Indirect and Post-Inc. | $(X) \leftarrow Rr, X \leftarrow X + 1$ | None | 2 |
| ST | -X, Rr | Store Indirect and Pre-Dec. | $X \leftarrow X - 1, (X) \leftarrow Rr$ | None | 2 |
| ST | Y, Rr | Store Indirect | $(Y) \leftarrow Rr$ | None | 2 |
| ST | Y+, Rr | Store Indirect and Post-Inc. | $(Y) \leftarrow Rr, Y \leftarrow Y + 1$ | None | 2 |
| ST | -Y, Rr | Store Indirect and Pre-Dec. | $Y \leftarrow Y - 1, (Y) \leftarrow Rr$ | None | 2 |
| STD | Y+q, Rr | Store Indirect with Displacement | $(Y + q) \leftarrow Rr$ | None | 2 |
| ST | Z, Rr | Store Indirect | $(Z) \leftarrow Rr$ | None | 2 |
| ST | Z+, Rr | Store Indirect and Post-Inc. | $(Z) \leftarrow Rr, Z \leftarrow Z + 1$ | None | 2 |
| ST | -Z, Rr | Store Indirect and Pre-Dec. | $Z \leftarrow Z - 1, (Z) \leftarrow Rr$ | None | 2 |
| STD | Z+q, Rr | Store Indirect with Displacement | $(Z + q) \leftarrow Rr$ | None | 2 |
| STS | k, Rr | Store Direct to SRAM | $(k) \leftarrow Rr$ | None | 2 |
| LPM | | Load Program Memory | $R0 \leftarrow (Z)$ | None | 3 |
| LPM | Rd, Z | Load Program Memory | $Rd \leftarrow (Z)$ | None | 3 |
| LPM | Rd, Z+ | Load Program Memory and Post-Inc | $Rd \leftarrow (Z), Z \leftarrow Z + 1$ | None | 3 |
| SPM | | Store Program Memory | $(Z) \leftarrow R1:R0$ | None | - |
| IN | Rd, P | In Port | $Rd \leftarrow P$ | None | 1 |
| OUT | P, Rr | Out Port | $P \leftarrow Rr$ | None | 1 |
| PUSH | Rr | Push Register on Stack | $STACK \leftarrow Rr$ | None | 2 |
| POP | Rd | Pop Register from Stack | $Rd \leftarrow STACK$ | None | 2 |
| MCU CONTROL INSTRUCTIONS | | | | | |



| Mnemonics | Operands | Description | Operation | Flags | #Clocks |
|-----------|----------|----------------|--|-------|---------|
| NOP | | No Operation | | None | 1 |
| SLEEP | | Sleep | (see specific descr. for Sleep function) | None | 1 |
| WDR | | Watchdog Reset | (see specific descr. for WDR/timer) | None | 1 |
| BREAK | | Break | For On-chip Debug Only | None | N/A |

KTTIC



7. Ordering Information

| Speed (MHz) | Power Supply | Ordering Code | Package | Operation Range |
|-------------|--------------|----------------|---------|---------------------------|
| 16 | 2.7 - 5.5V | AT90PWM3-16SQ | SO32 | Extended (-40°C to 105°C) |
| 16 | 2.7 - 5.5V | AT90PWM3-16MQT | QFN32 | Extended (-40°C to 105°C) |
| 16 | 2.7 - 5.5V | AT90PWM2-16SQ | SO24 | Extended (-40°C to 105°C) |
| 16 | 2.7 - 5.5V | AT90PWM3B-16SE | SO32 | Engineering Samples |
| 16 | 2.7 - 5.5V | AT90PWM3B-16ME | QFN32 | Engineering Samples |
| 16 | 2.7 - 5.5V | AT90PWM2B-16SE | SO24 | Engineering Samples |
| 16 | 2.7 - 5.5V | AT90PWM3B-16SU | SO32 | Extended (-40°C to 105°C) |
| 16 | 2.7 - 5.5V | AT90PWM3B-16MU | QFN32 | Extended (-40°C to 105°C) |
| 16 | 2.7 - 5.5V | AT90PWM2B-16SU | SO24 | Extended (-40°C to 105°C) |

Note: All packages are Pb free, fully LHF

Note: This device can also be supplied in wafer form. Please contact your local Atmel sales office for detailed ordering information and minimum quantities.

Note: Parts numbers are for shipping in sticks (SO) or in trays (QFN). These devices can also be supplied in Tape and Reel. Please contact your local Atmel sales office for detailed ordering information and minimum quantities.

Note: PWM2 is not recommended for new designs, use PWM2B for your developments

Note: PWM3 is not recommended for new designs, use PWM3B for your developments

KTTIC



8. Package Information

| Package Type | |
|--------------|--------------------------------|
| SO24 | 24-Lead, Small Outline Package |
| SO32 | 32-Lead, Small Outline Package |
| QFN32 | 32-Lead, Quad Flat No lead |

KTTIC



8.1 SO24

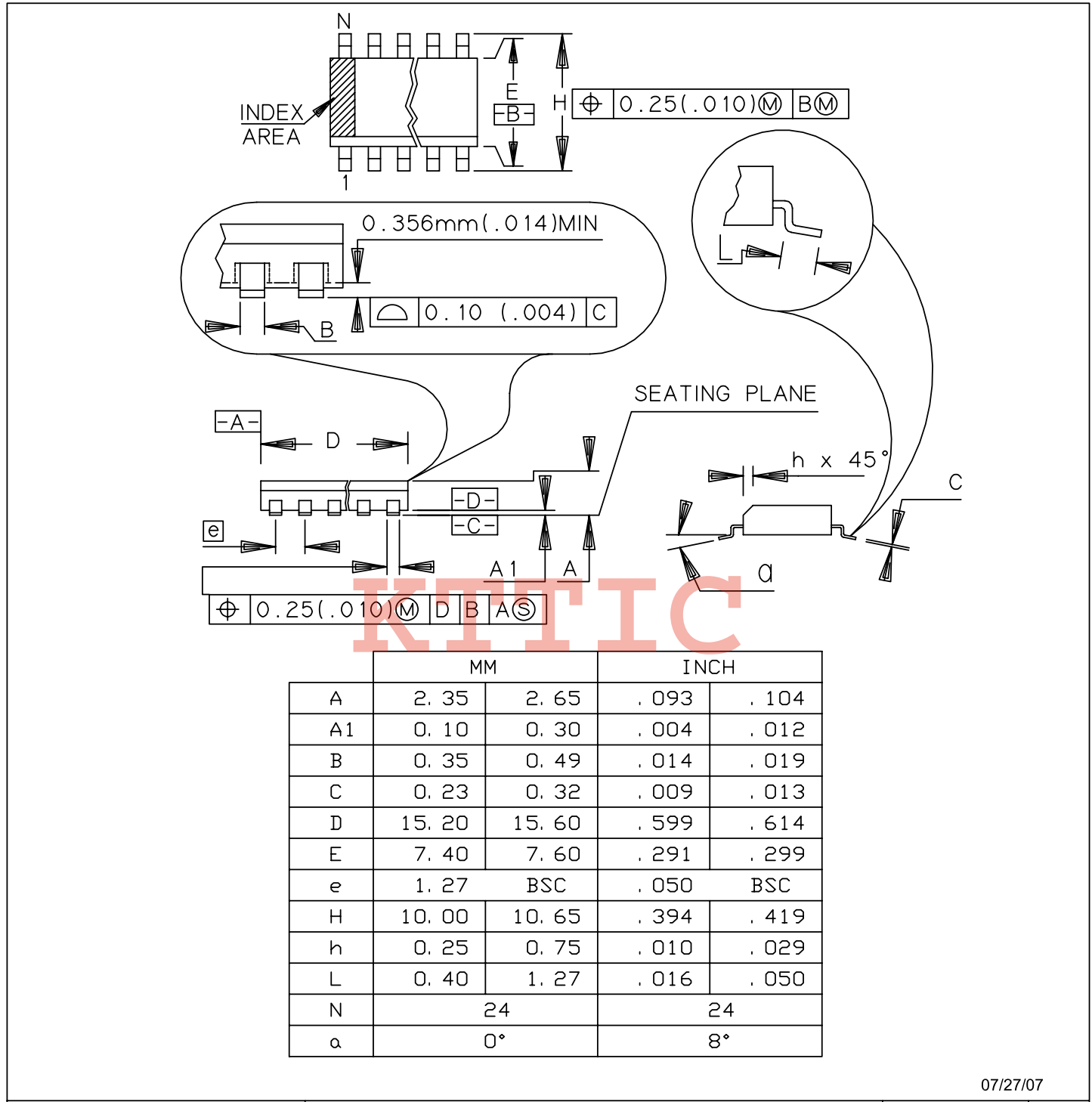

| | MM | | INCH | |
|----|-------|-------|------|------|
| A | 2.35 | 2.65 | .093 | .104 |
| A1 | 0.10 | 0.30 | .004 | .012 |
| B | 0.35 | 0.49 | .014 | .019 |
| C | 0.23 | 0.32 | .009 | .013 |
| D | 15.20 | 15.60 | .599 | .614 |
| E | 7.40 | 7.60 | .291 | .299 |
| e | 1.27 | BSC | .050 | BSC |
| H | 10.00 | 10.65 | .394 | .419 |
| h | 0.25 | 0.75 | .010 | .029 |
| L | 0.40 | 1.27 | .016 | .050 |
| N | 24 | | 24 | |
| α | 0° | | 8° | |

07/27/07

Atmel Nantes S.A.
La Chantrerie - BP 70602
44306 Nantes Cedex 3 - France

TITLE
TD, 24 - Lead, 0.300" Body Width
Plastic Gull Wing Small Outline Package (SOIC)

| | |
|-------------|------|
| DRAWING No. | REV. |
| TD | A |



8.2 SO32

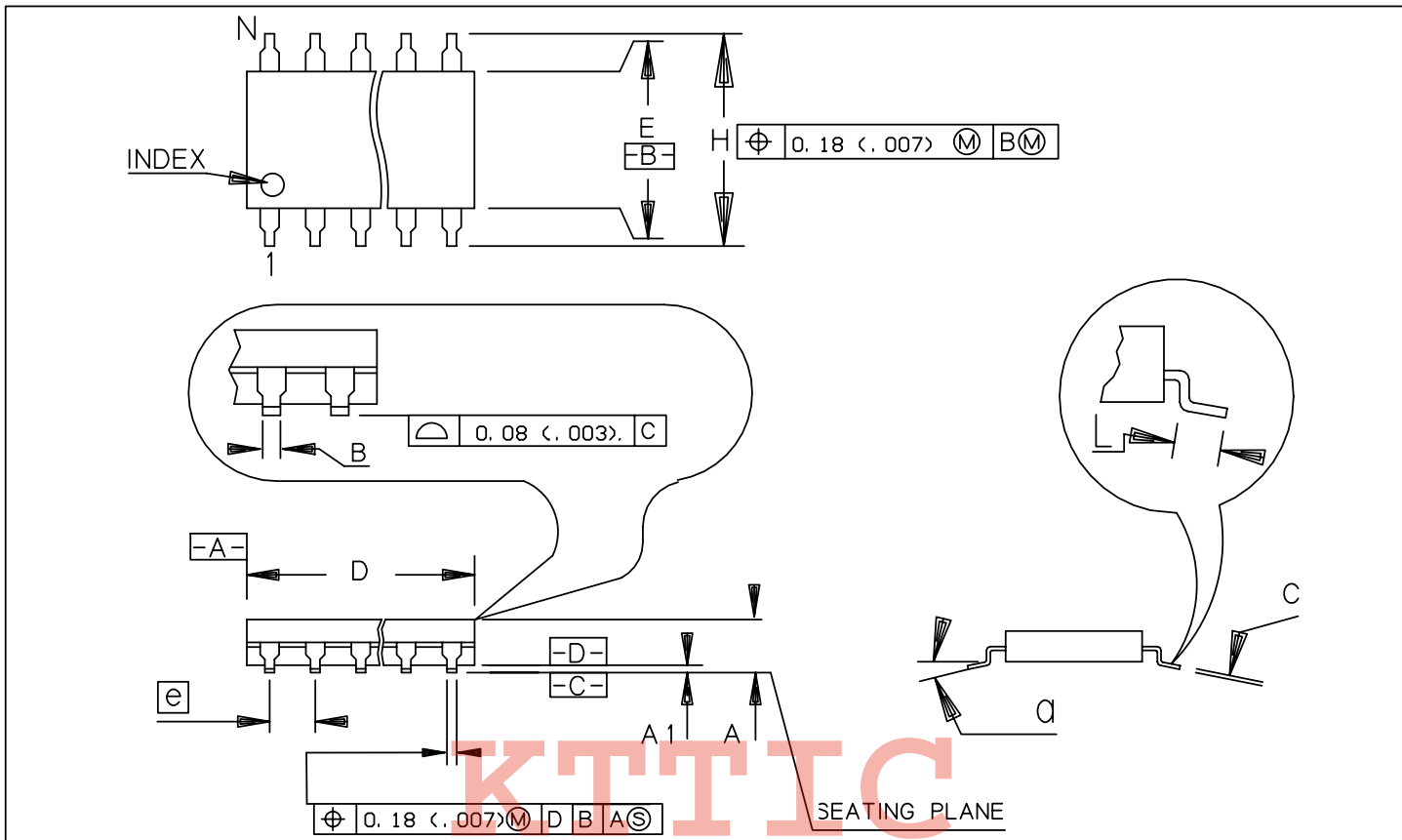

| | MM | | INCH | |
|----|-------|-------|------|------|
| | Min | Max | Min | Max |
| A | 2.29 | 2.54 | .090 | .100 |
| A1 | 0.10 | 0.25 | .004 | .010 |
| B | 0.36 | 0.51 | .014 | .020 |
| C | 0.15 | 0.32 | .006 | .013 |
| D | 20.57 | 20.88 | .810 | .822 |
| E | 7.42 | 7.60 | .292 | .299 |
| e | 1.27 | BSC | .050 | BSC |
| H | 10.29 | 10.64 | .405 | .419 |
| L | 0.53 | 1.04 | .021 | .041 |
| N | 32 | | 32 | |
| α | 4° | | 4° | |

07/27/07

 Atmel Nantes S.A.
La Chantrerie - BP 70602
44306 Nantes Cedex 3 - France

TITLE
T4, 32 - Lead, 0.300" Body Width
Plastic Gull Wing Small Outline Package (SOIC)

| | |
|-------------|------|
| DRAWING No. | REV. |
| T4 | A |

8.3 QFN32

32 LEADS MicroLEADFRAME

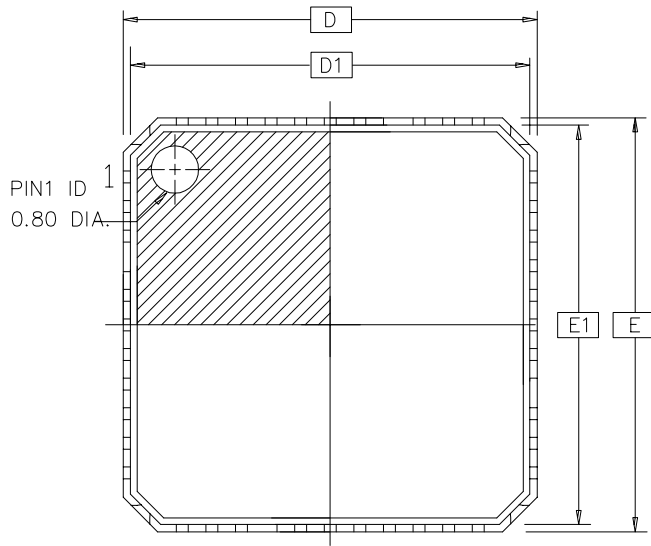

TOP VIEW

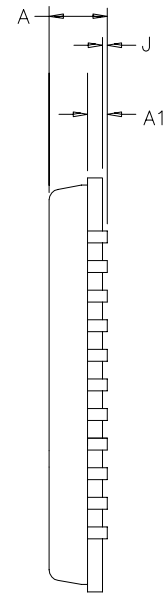

SIDE VIEW

DRAWINGS NOT SCALED
KTTIC

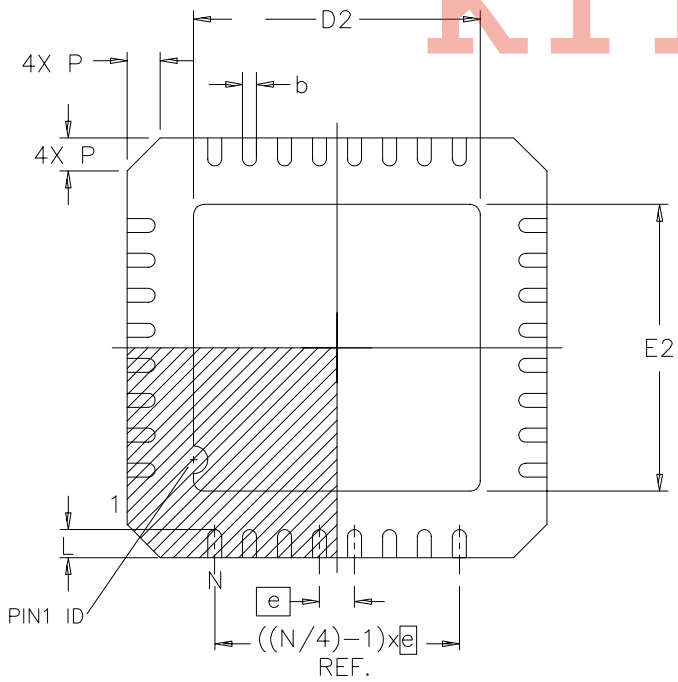

| | MM | | | INCH | | |
|-------|----------|------|------|----------|------|------|
| | MIN | NOM | MAX | MIN | NOM | MAX |
| A | 0.80 | - | 1.00 | .032 | - | .040 |
| J | 0.00 | 0.01 | 0.05 | .000 | .000 | .002 |
| A1 | 0.20 ref | | | .008 ref | | |
| D/E | 7.00 BSC | | | .276 BSC | | |
| D1/E1 | 6.75 BSC | | | .266 BSC | | |
| D2/E2 | 2.25 | - | 5.25 | .090 | - | .207 |
| N | 32 | | | | | |
| P | 0.24 | 0.42 | 0.60 | .009 | .016 | .024 |
| e | 0.65 BSC | | | .026 BSC | | |
| L | 0.35 | - | 0.75 | .014 | - | .030 |
| b | 0.23 | - | 0.35 | .009 | - | .014 |



NOTES: MLF PACKAGE FAMILY

1. DIE THICKNESS ALLOWABLE IS 0.305mm MAXIMUM(.012 INCHES MAXIMUM)
2. DIMENSIONING & TOLERANCES CONFORM TO ASME Y14.5M. – 1994.
- 3 DIMENSION b APPLIES TO PLATED TERMINAL AND IS MEASURED
BETWEEN 0.20 AND 0.25mm FROM TERMINAL TIP.
- 4 PACKAGE WARPAGE MAX 0.08mm.
- 5 THE PIN #1 IDENTIFIER MUST BE EXISTED ON THE TOP SURFACE OF THE
PACKAGE BY USING INDENTATION MARK OR OTHER FEATURE OF PACKAGE BODY.
- 6 EXACT SHAPE AND SIZE OF THIS FIXTURE IS OPTIONAL

KTTIC

9. Errata

9.1 AT90PWM2&3 Rev. A (Mask Revision)

- PGM: PSCxRB Fuse
- PSC: Prescaler
- PSC: PAOCnA and PAOCnB Register Bits (Asynchronous output control)
- PSC: PEVxA/B Flag Bits
- PSC: Output Polarity in Centered Mode
- PSC: Output Activity
- VREF
- DALI
- DAC: Register Update
- DAC: Output spikes
- DAC driver: Output Voltage linearity
- ADC: Conversion accuracy
- Analog comparator: Offset value
- Analog comparator: Output signal
- PSC: Autolock modes
- DALI: 17th bit detection
- PSC: One ramp mode with PSC input mode 8

1. PGM: PSCnRB Fuse

The use of PSCnRB fuse can make the parallel ISP fail.

Workaround:

When PSCnRB fuses are used, use the serial programming mode to load a new program version.

2. PSC: Prescaler

The use of PSC's prescaler have the following effects :

It blocks the sample of PSC inputs until the two first cycles following the set of PSC run bit.

A fault is not properly transferred to other (slave) PSC.

Workaround:

Clear the prescaler PPREx bit when stopping the PSC (prun = 0), and set them to appropriate value when starting the PSC (prun = 1), these bits are in the same PCTL register

Do not use the prescaler when a fault on one PSC should affect other PSC's

3. PSC: PAOCnA and PAOCnB Register Bits (Asynchronous output control)

These register bits are malfunctioning.

Workaround:

Do not use this feature.

4. PSC: PEVnA/B flag bits

These flags are set when a fault arises, but can also be set again during the fault itself.

Workaround:

Don't clear these flags before the fault disappears.

5. PSC: Output Polarity in Centered Mode

In centered mode, PSCOUTn1 outputs are not inverted, so they are active at the same time as PSCOUTn0.

Workaround:

Use an external inverter (or a driver with inverting output) to drive the load on PSCOUTn1.

6. PSC : POACnA/B Output Activity

These register bits are not implemented in rev A.

Workaround:

Do not use this feature.

7. VREF

Remark: To have Internal Vref on AREF pin select an internal analog feature such as DAC or ADC.

Some stand by power consumption may be observed if Vref equals AVcc

8. DALI

Some troubles on Dali extension when edges are not symmetric.

Workaround:

Use an optocoupler providing symmetric edges on Rx and Tx DALI lines (only recommended for software validation purpose).

9. DAC: Register Update

Registers DACL & DACH are not written when the DAC is not enabled.

Workaround:

Enable DAC with DAEN before writing in DACL & DACH. To prevent an unwanted zero output on DAC pin, enable DAC output, with DAOE afterwards.

10. DAC : Output spikes

During transition between two codes, a spike may appears

Work around:

Filter spike or wait for steady state

No spike appears if the 4 last significant bits remain zero.

11. DAC driver: Output Voltage linearity

The voltage linearity of the DAC driver is limited when the DAC output goes above Vcc - 1V.

Work around:

Do not use AVcc as Vref ; internal Vref gives good results

12. ADC : Conversion accuracy

The conversion accuracy degrades when the ADC clock is 1 & 2 MHz.

Work around:

When a 10 bit conversion accuracy is required, use an ADC clock of 500 kHz or below.

13. Analog comparator: Offset value

The offset value increases when the common mode voltage is above Vcc - 1.5V.

Work around:

Limit common mode voltage

14. Analog comparator: Output signal

The comparator output toggles at the comparator clock frequency when the voltage difference between both inputs is lower than the offset. This may occur when comparing signal with small slew rate.

Work around:

This effect normally do not impact the PSC, as the transition is sampled once per PSC cycle. Be carefull when using the comparator as an interrupt source.

15. PSC : Autolock mode

This mode is not properly handled when CLKPSC is different from CLK IO.

Work around:

With CLKPSC equals 64/32 MHz (CLKPLL), use LOCK mode

16. DALI : 17th bit detection

17th bit detection do not occurs if the signal arrives after the sampling point.

Workaround:

Use this feature only for software development and not in field conditions

17. PSC : One ramp mode with PSC input mode 8

The retriggering is not properly handled in this case.

Work around:

Do not program this case.

18. PSC : Desactivation of outputs in mode 14

See "PSC Input Mode 14: Fixed Frequency Edge Retrigger PSC and Disactivate Output" on page 155.

Work around:

Do not use this mode to desactivate output if retrigger event do not occurs during On-Time.

9.2 AT90PWM2B/3B

- **PSC : Double End-Of-Cycle Interrupt Request in Centered Mode**
- **ADC : Conversion accuracy**
- 1. **PSC : Double End-Of-Cycle Interrupt Request in Centered Mode**

In centered mode, after the "expected" End-Of-Cycle Interrupt, a second unexpected Interrupt occurs 1 PSC cycle after the previous interrupt.

Work around:

While CPU cycle is lower than PSC clock, the CPU sees only one interrupt request. For PSC clock period greater than CPU cycle, the second interrupt request must be cleared by software.

2. **ADC : Conversion accuracy**

The conversion accuracy degrades when the ADC clock is 2 MHz.

Work around:

When a 10 bit conversion accuracy is required, use an ADC clock of 1 MHz or below.

At 2 Mhz the ADC can be used as a 7 bits ADC.

3. **DAC Driver linearity above 3.6V**

With 5V Vcc, the DAC driver linearity is poor when DAC output level is above Vcc-1V. At 5V, DAC output for 1023 will be around 5V - 40mV.

Work around: .



Use, when $V_{cc}=5V$, V_{ref} below $V_{cc}-1V$.

Or, when $V_{ref}=V_{cc}=5V$, do not use codes above 800.

4. DAC Update in Autotrig mode

If the CPU writes in DACH register at the same instant that the selected trigger source occurs and DAC Auto Trigger is enabled, the DACH register is not updated by the new value.

Work around: .

When using the autotrig mode, write twice in the DACH register. The time between the two CPU writes, must be different than the trigger source frequency.

KTTIC

10. Datasheet Revision History for AT90PWM2/2B/3/3B

Please note that the referring page numbers in this section are referred to this document. The referring revision in this section are referring to the document revision.

10.1 Changes from 4317A- to 4317B

1. PSC section has been rewritten.
2. Suppression of description of RAMPZ which does not exist.

10.2 Changes from 4317B- to 4317C

1. Added AT90PWM2B/3B Advance Information.
2. Various updates throughout the document.

10.3 Changes from 4317C- to 4317D

1. Update of Electrical and Typical Characteristics.

10.4 Changes from 4317D to 4317E

1. Changed product status from “Advanced Information” to “Preliminary”.

10.5 Changes from 4317E to 4317F

1. Remove JMP and CALL instruction in the Instruction Set Summary
2. Daisy chain of PSC input is only done in mode 7 - See “Fault events in Autorun mode” on page 160.
3. Updated “Output Compare SA Register – OCRnSAH and OCRnSAL” on page 163
4. Updated “Output Compare RA Register – OCRnRAH and OCRnRAL” on page 163
5. Updated “Output Compare SB Register – OCRnSBH and OCRnSBL” on page 163
6. Updated “Output Compare RB Register – OCRnRBH and OCRnRBL” on page 164
7. Specify the “Analog Comparator Propagation Delay” - See “DC Characteristics” on page 300.
8. Specify the “Reset Characteristics” - See “Reset Characteristics(1)” on page 47.
9. Specify the “Brown-out Characteristics” - See “Brown-out Characteristics(1)” on page 49.
10. Specify the “Internal Voltage Reference Characteristics - See “Internal Voltage Reference Characteristics(1)” on page 51.

10.6 Changes from 4317F to 4317G

1. Describe the amplifier operation for Rev B.
2. Clarify the fact that the DAC load given is the worst case.
3. Specify the ADC Min and Max clock frequency.
4. Describe the retrigger mode 8 in one ramp mode.
5. Specify that the amplifier only provides a 8 bits accuracy.

10.7 Changes from 4317G to 4317H

1. Updated “History” on page 2
2. Specify the “AREF Voltage vs. Temperature” on page 329

3. PSC : the Balance Flank Width Modulation is done On-Time 1 rather than On-Time 0 (correction of figures)
4. Updated “Maximum Speed vs. VCC” on page 303 (formulas are removed)
5. Update of the “Errata” on page 23

10.8 Changes from 4317H to 4317I

1. Updated “History” on page 2
2. Updated “Device Clocking Options Select AT90PWM2B/3B” on page 31
3. Updated “Start-up Times when the PLL is selected as system clock” on page 35
4. Updated “ADC Noise Canceler” on page 241
5. Updated “ADC Auto Trigger Source Selection for non amplified conversions” on page 250.
6. Added “ADC Auto Trigger Source Selection for amplified conversions” on page 250
7. Updated “Amplifier” on page 252
8. Updated “Amplifier 0 Control and Status register – AMP0CSR” on page 256
9. Updated “AMP0 Auto Trigger Source Selection” on page 257
10. Updated “Amplifier 1 Control and Status register – AMP1CSR” on page 257
11. Updated “AMP1 Auto Trigger source selection” on page 258
12. Updated DAC “Features” on page 259 (Output Impedance)
13. Updated temperature range in “DC Characteristics” on page 300
14. Updated V_{hysr} in “DC Characteristics” on page 300
15. Updated “ADC Characteristics” on page 306
16. Updated “Example 1” on page 315
17. Updated “Example 2” on page 315
18. Updated “Example 3” on page 316
19. Added “I/O Pin Input Hysteresis Voltage vs. VCC” on page 322
20. Updated “Ordering Information” on page 17
21. Added Errata for “AT90PWM2B/3B” on page 25
22. Updated Package Drawings “Package Information” on page 18.
23. Updated table on page 2.
24. Updated “Calibrated Internal RC Oscillator” on page 33.
25. Added “Calibrated Internal RC Oscillator Accuracy” on page 302.
26. Updated Figure 27-35 on page 329.
27. Updated Figure 27-36 on page 330.
28. Updated Figure 27-37 on page 330.